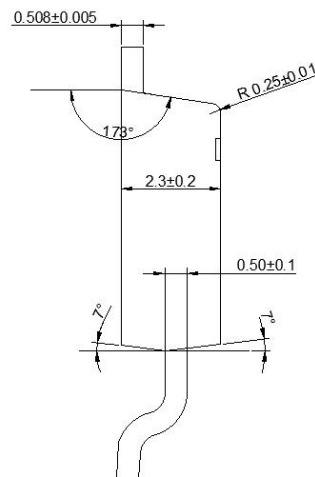
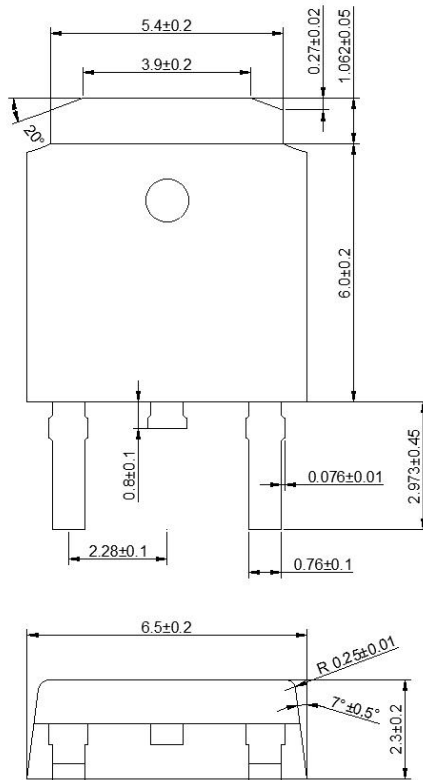
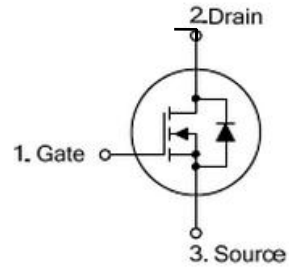

**LOW Voltage N-CHANNEL MOSFET**
**◆ Features:**

- ✧ Fast switching speed  
开关速度快
- ✧ Low gate charge  
低门充电
- ✧ High power and current handling capability  
高功率和电流处理能力
- ✧ ROHS compliant  
符合 ROHS 标准

**◆ Applications**

- ✧ DC to DC converters  
直流到直流转换
- ✧ Synchronous Rectification  
同步整流

**TO-252**

单位: mm  
**TO-252**

**◆ Absolute Maximum Ratings (Tc=25°C)**

Symbol	Parameters	Ratings	Unit
V <sub>DSS</sub>	Drain-Source Voltage 漏源电压	<b>20</b>	V
V <sub>GS</sub>	Gate-Source Voltage-Continuous 栅源电压	<b>±10</b>	V
I <sub>D</sub>	Drain Current-Continuous (Note 2) 漏极持续电流	<b>40</b>	A
I <sub>DM</sub>	Drain Current-Single Plused (Note 1) 漏极单次脉冲电流	<b>160</b>	A
P <sub>D</sub>	Power Dissipation (Note 2) 功率损耗	<b>50</b>	W
T <sub>j</sub>	Max.Operating junction temperature 最大结温	<b>150</b>	°C

**◆ Electrical characteristics (Tc=25°C unless otherwise noted)**

Symbol	Parameters	Min	Typ	Max	Units	Conditions
<b>Static Characteristics</b>						
B <sub>VDSS</sub>	Drain-Source Breakdown Voltage Current (Note 1) 漏极击穿电压	<b>20</b>	--	--	V	I <sub>D</sub> =250μA, V <sub>GS</sub> =0V
V <sub>GS(th)</sub>	Gate Threshold Voltage 栅极开启电压	<b>0.4</b>	--	<b>1.0</b>	V	V <sub>DS</sub> =V <sub>GS</sub> , I <sub>D</sub> =250μA
R <sub>DS(on)</sub>	Drain-Source On-Resistance 漏源导通电阻	--	<b>7.5</b>	<b>8.6</b>	mΩ	V <sub>GS</sub> =4.5V, I <sub>D</sub> =20A
I <sub>GSS</sub>	Gate-Body Leakage Current 栅极漏电流	--	--	<b>±100</b>	nA	V <sub>GS</sub> =±10V, V <sub>DS</sub> =0
I <sub>DSS</sub>	Zero Gate Voltage Drain Current 零栅极电压漏极电流	--	--	<b>1</b>	μA	V <sub>DS</sub> =20V, V <sub>GS</sub> =0
g <sub>fs</sub>	Forward Trans conductance 正向跨导	--	<b>24</b>	--	S	V <sub>DS</sub> =10V, I <sub>D</sub> =20A

**LOW Voltage N-CHANNEL MOSFET**

Switching Characteristics						
$T_{d(on)}$	Turn-On Delay Time 开启延迟时间	--	<b>7.5</b>	--	ns	$V_{GS}=10V,$ $V_{DS}=10V, I_D=20A,$ $R_G=5\Omega$
$T_r$	Rise Time 上升时间	--	<b>15</b>	--	ns	
$T_{d(off)}$	Turn-Off Delay Time 关闭延迟时间	--	<b>30.5</b>	--	ns	
$T_f$	Fall Time 下降时间	--	<b>20</b>	--	ns	
$Q_g$	Total Gate Charge 栅极总电荷	--	<b>18</b>	--	nC	$V_{DS}=20, V_{GS}=4.5V,$ $I_D=10A$
$Q_{gs}$	Gate-Source Charge 栅源极电荷	--	<b>2.3</b>	--	nC	
$Q_{gd}$	Gate-Drain Charge 栅漏极电荷	--	<b>8.5</b>	--	nC	
Dynamic Characteristics						
$C_{iss}$	Input Capacitance 输入电容	--	<b>1200</b>	--	pF	$V_{DS}=15V, V_{GS}=0,$ $f=1MHz$
$C_{oss}$	Output Capacitance 输出电容	--	<b>250</b>	--	pF	
$C_{rss}$	Reverse Transfer Capacitance 反向传输电容	--	<b>158</b>	--	pF	
$I_S$	Continuous Drain-Source Diode Forward Current (Note 2) 二极管导通正向持续电流	--	--	<b>40</b>	A	
$V_{SD}$	Diode Forward On-Voltage 二极管正向导通电压	--	--	<b>1.0</b>	V	$I_S=30A, V_{GS}=0$
$R_{th(j-c)}$	Thermal Resistance, Junction to Case 结到外壳的热阻	--	--	<b>2.50</b>	$^{\circ}C/W$	

Note 1: Repetitive Rating : Pulse width limited by maximum junction temperature

Note 2: Pulse test: PW  $\leq$  300us , duty cycle  $\leq$  2%.