

1. General Description

The 74AHC1G04 and 74AHCT1G04 are single inverters. Inputs are overvoltage tolerant. This feature allows the use of these devices as translators in mixed voltage environments.

The AHC device has CMOS input switching levels and supply voltage range 2 V to 5.5 V.

The AHCT device has TTL input switching levels and supply voltage range 4.5 V to 5.5 V.

2. Features and Benefits

- Wide supply voltage range from 2.0 V to 5.5 V
- Overvoltage tolerant inputs to 5.5 V
- High noise immunity
- CMOS low power dissipation
- Latch-up performance exceeds 200 mA
- Symmetrical output impedance
- Balanced propagation delays
- Input levels:
 - For 74AHC1G04: CMOS level
 - For 74AHCT1G04: TTL level
- ESD protection:
 - HBM ANSI/ESDA/JEDEC JS-001 Class 3A exceeds 7000 V
 - CDM ANSI/ESDA/JEDEC JS-002 Class C3 exceeds 2000 V
- Multiple package options

3. Ordering Information

Table 1. Ordering information

Type number	Package		
	Name	Description	Quantity
74AHC1G04GV	SOT23-5L	SOT23 package, 5 pins 2.92 mm × 1.6 mm; 1.25 mm (Max) height	3000
74AHCT1G04GV			
74AHC1G04GW	SOT353	SOT353 package, 5 pins 2.1 mm × 1.25 mm; 1.1 mm (Max) height	3000
74AHCT1G04GW			
74AHC1G04DRL	SOT553	SOT553 package, 5 pins 1.6 mm × 1.2 mm; 0.6 mm (Max) height	3000
74AHCT1G04DRL			

4. Function Diagram

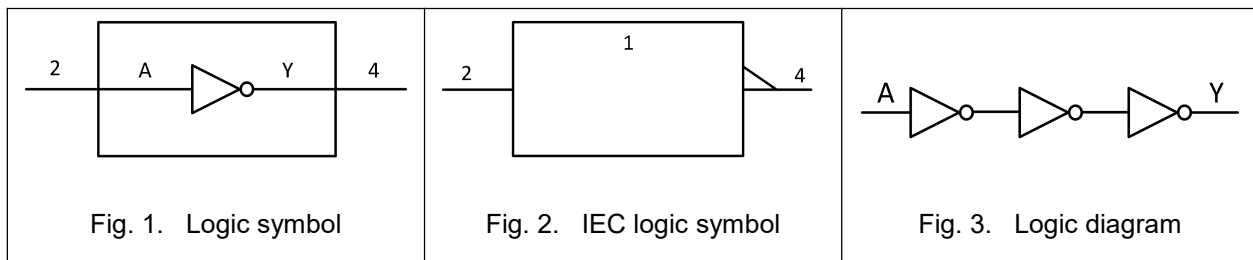

5. Pinning Information

5.1. Pinning

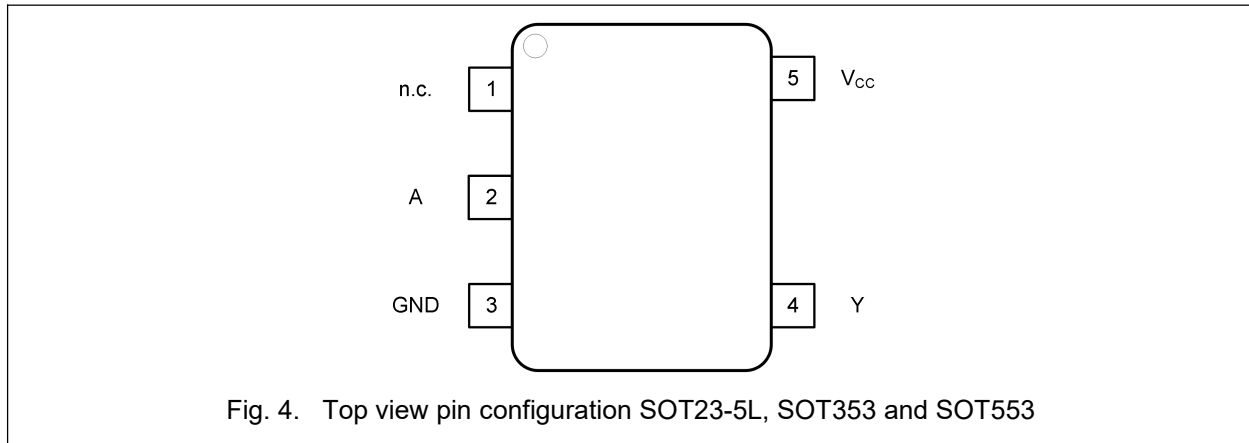

5.2. Pin description

Table 2. Pin description

Symbol	Pin	Description
n.c.	1	Not connected
A	2	Data input
GND	3	Ground (0V)
Y	4	Data output
V _{CC}	5	Supply voltage

6. Functional Description

Table 3. Function table

H = HIGH voltage level; L = LOW voltage level.

Input	Output
A	Y
L	H
H	L

7. Absolute Maximum Ratings

Stresses exceeding the absolute maximum ratings may damage the device. The device may not function or be operable above the recommended operating conditions and stressing the parts to these levels is not recommended. In addition, extended exposure to stresses above the recommended operating conditions may affect device reliability. The absolute maximum ratings are stress ratings only.

Table 4. Absolute Maximum Ratings

In accordance with the Absolute Maximum Rating System (IEC 60134). Voltages are referenced to GND.

Symbol	Parameter	Conditions	Min	Max	Unit
V_{CC}	supply voltage		-0.5	7.0	V
V_I	input voltage		-0.5	7.0	V
I_{IK}	input clamping current	$V_I < -0.5\text{ V}$	-20		mA
I_{OK}	output clamping current	$V_O < -0.5\text{ V}$ or $V_O > V_{CC} + 0.5\text{ V}$ [1]		± 20	mA
I_O	output current	$-0.5\text{ V} < V_O < V_{CC} + 0.5\text{ V}$		± 25	mA
I_{CC}	supply current			75	mA
I_{GND}	ground current		-75		mA
P_{tot}	total power dissipation	$T_{amb} = -40\text{ °C}$ to $+125\text{ °C}$		250	mW
T_{stg}	storage temperature		-65	150	°C

[1] The input and output voltage ratings may be exceeded if the input and output current ratings are observed.

8. Recommended Operating Conditions

The Recommended Operating Conditions table defines the conditions for actual device operation. Recommended operating conditions are specified to ensure optimal performance to the datasheet specifications. EnergyMath does not recommend exceeding them or designing to Absolute Maximum Ratings.

Table 5. Recommended Operating Conditions

Symbol	Parameter	Conditions	74AHC1G04			74AHCT1G04			Unit
			Min	Typ	Max	Min	Typ	Max	
V_{CC}	supply voltage		2.0	5.0	5.5	4.5	5.0	5.5	V
V_I	input voltage		0		5.5	0		5.5	V
V_O	output voltage		0		V_{CC}	0		V_{CC}	V
T_{amb}	ambient temperature		-40	25	125	-40	25	125	°C
$\Delta t/\Delta V$	input transition rise and fall rate	$V_{CC} = 3.3\text{ V} \pm 0.3\text{ V}$			100				ns/V
		$V_{CC} = 5.0\text{ V} \pm 0.5\text{ V}$			20			20	ns/V

9. Static Characteristics

Table 6. Static characteristics

At recommended operating conditions. Voltages are referenced to GND (ground = 0 V).

Symbol	Parameter	Conditions	-40 °C to +85 °C			-40 °C to +125 °C		Unit
			Min	Typ[1]	Max	Min	Max	
74AHC1G04								
V _{IH}	HIGH-level input voltage	V _{CC} = 2.0 V	1.5			1.5		V
		V _{CC} = 3.0 V	2.1			2.1		V
		V _{CC} = 5.5 V	3.85			3.85		V
V _{IL}	LOW-level input voltage	V _{CC} = 2.0 V			0.5		0.5	V
		V _{CC} = 3.0 V			0.9		0.9	V
		V _{CC} = 5.5 V			1.65		1.65	V
V _{OH}	HIGH-level output voltage	V _I = V _{IH} or V _{IL}						
		I _O = -50 μA; V _{CC} = 2.0 V	1.9	2.0		1.9		V
		I _O = -50 μA; V _{CC} = 3.0 V	2.9	3.0		2.9		V
		I _O = -50 μA; V _{CC} = 4.5 V	4.4	4.5		4.4		V
		I _O = -4.0 mA; V _{CC} = 3.0 V	2.48	2.93		2.40		V
		I _O = -8.0 mA; V _{CC} = 4.5 V	3.80	4.39		3.70		V
V _{OL}	LOW-level output voltage	V _I = V _{IH} or V _{IL}						
		I _O = 50 μA; V _{CC} = 2.0 V		0	0.1		0.1	V
		I _O = 50 μA; V _{CC} = 3.0 V		0	0.1		0.1	V
		I _O = 50 μA; V _{CC} = 4.5 V		0	0.1		0.1	V
		I _O = 4.0 mA; V _{CC} = 3.0 V		0.05	0.44		0.55	V
		I _O = 8.0 mA; V _{CC} = 4.5 V		0.07	0.44		0.55	V
I _I	input leakage current	V _I = 5.5 V or GND ; V _{CC} = 0 V to 5.5 V		±0.01	±1.0		±2.0	μA
I _{CC}	supply current	V _I = V _{CC} or GND ; I _O = 0 A ; V _{CC} = 5.5 V		0.01	10		40	μA
C _I	input capacitance			3.5				pF

74AHC1G04; 74AHCT1G04

Inverter

Symbol	Parameter	Conditions	-40 °C to +85 °C			-40 °C to +125 °C		Unit
			Min	Typ[1]	Max	Min	Max	
74AHCT1G04								
V_{IH}	HIGH-level input voltage	$V_{CC} = 4.5 \text{ V to } 5.5 \text{ V}$	2.0			2.0		V
V_{IL}	LOW-level input voltage	$V_{CC} = 4.5 \text{ V to } 5.5 \text{ V}$			0.8		0.8	V
V_{OH}	HIGH-level output voltage	$V_I = V_{IH} \text{ or } V_{IL}; V_{CC} = 4.5 \text{ V}$						
		$I_O = -50 \mu\text{A};$	4.4	4.5		4.4		V
V_{OL}	LOW-level output voltage	$V_I = V_{IH} \text{ or } V_{IL}; V_{CC} = 4.5 \text{ V}$						
		$I_O = 50 \mu\text{A};$		0	0.1		0.1	V
V_{OL}	LOW-level output voltage	$I_O = 8.0 \text{ mA};$	3.80	4.39		3.70		V
I_I	input leakage current	$V_I = 5.5 \text{ V or GND};$ $V_{CC} = 0 \text{ V to } 5.5 \text{ V}$		± 0.01	± 1.0		± 2.0	μA
I_{CC}	supply current	$V_I = V_{CC} \text{ or GND}; I_O = 0 \text{ A};$ $V_{CC} = 5.5 \text{ V}$		0.01	10		40	μA
ΔI_{CC}	additional supply current	per input pin ; $V_I = 3.4 \text{ V};$ other inputs at V_{CC} or GND; $I_O = 0 \text{ A}; V_{CC} = 5.5 \text{ V}$		0.23	1.35		1.35	mA
C_i	input capacitance			3.5				pF

[1] All typical values are measured at $T_{amb} = 25^\circ\text{C}$.

10. Dynamic Characteristics

Table 7. Dynamic characteristics

Voltages are referenced to GND (ground = 0 V); for test circuit see Fig. 6.

Symbol	Parameter	Conditions	-40 °C to +85 °C			-40 °C to +125 °C		Unit
			Min	Typ[1]	Max	Min	Max	
74AHC1G04								
t_{pd}	propagation delay	A to Y; see Fig. 5 [2]						
		$V_{CC} = 3.0\text{ V to }3.6\text{ V}, C_L = 15\text{ pF}$	1.0	4.3	9.5	1.0	10.0	ns
		$V_{CC} = 4.5\text{ V to }5.5\text{ V}, C_L = 15\text{ pF}$	1.0	3.1	6.5	1.0	7.0	ns
C_{PD}	power dissipation capacitance	$C_L = 15\text{ pF}; f = 1\text{ MHz}; V_i = \text{GND to } V_{CC};$ [3]		20				pF
74AHCT1G04								
t_{pd}	propagation delay	A to Y; see Fig. 5 [2]						
		$V_{CC} = 4.5\text{ V to }5.5\text{ V}, C_L = 15\text{ pF}$	1.0	4.3	8.0	1.0	8.5	ns
C_{PD}	power dissipation capacitance	$C_L = 15\text{ pF}; f = 1\text{ MHz}; V_i = \text{GND to } V_{CC};$ [3]		21				pF

 [1] Typical values are measured at $T_{amb} = 25\text{ °C}$ and $V_{CC} = 3.3\text{ V}$ and 5.0 V respectively.

 [2] t_{pd} is the same as t_{PLH} and t_{PHL} .

 [3] C_{PD} is used to determine the dynamic power dissipation (P_D in μW).

$$P_D = C_{PD} \times V_{CC}^2 \times f_i \times N + \sum(C_L \times V_{CC}^2 \times f_o) \text{ where:}$$

 f_i = input frequency in MHz;

 f_o = output frequency in MHz;

 C_L = output load capacitance in pF;

 V_{CC} = supply voltage in V;

 N = number of inputs switching;

 $\sum(C_L \times V_{CC}^2 \times f_o)$ = sum of outputs.

10.1. Waveforms and test circuit

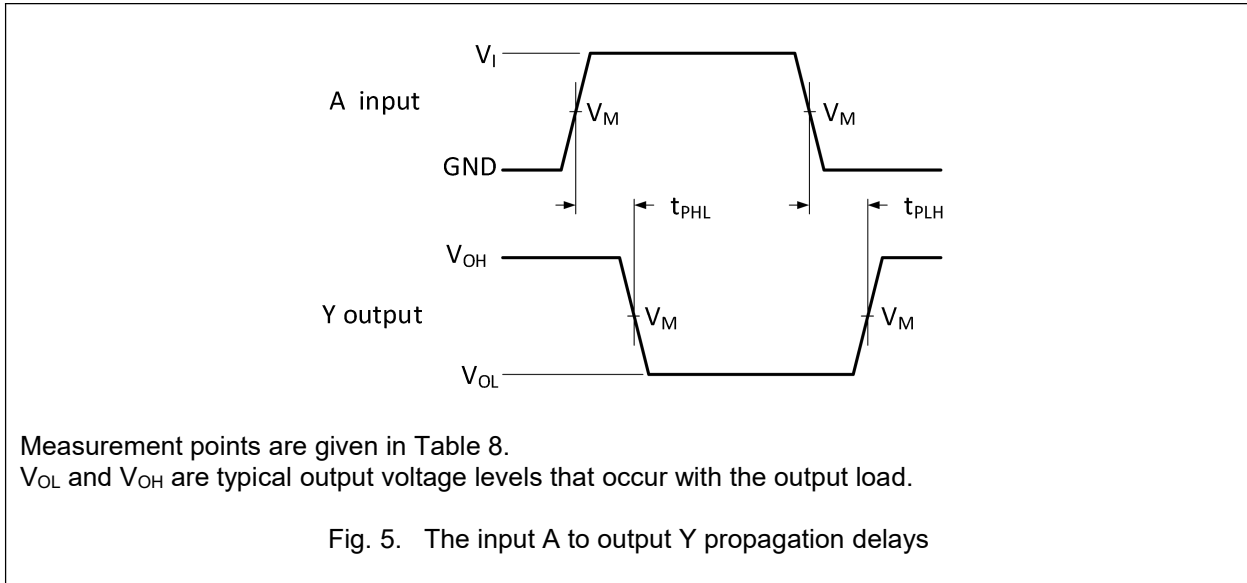
Table 8. Measurement points

Type	Input		Output
	V_I	V_M	V_M
74AHC1G04	GND to V_{CC}	$0.5 \times V_{CC}$	$0.5 \times V_{CC}$
74AHCT1G04	GND to 3.0 V	1.5 V	$0.5 \times V_{CC}$

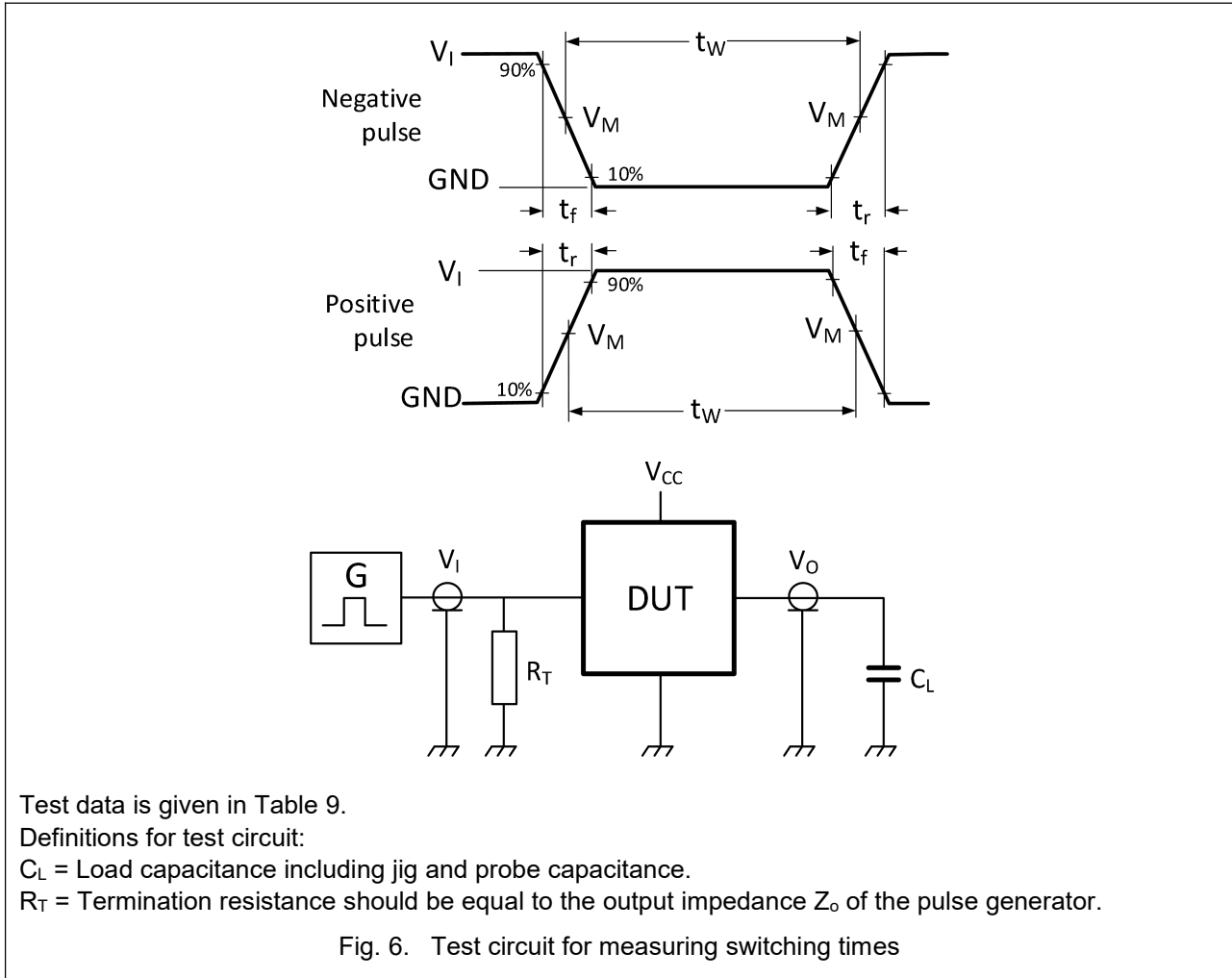
Table 9. Test data

Type	Input	Load
	$t_r = t_f$	C_L
74AHC1G04	≤ 2.5 ns	15 pF
74AHCT1G04	≤ 2.5 ns	15 pF

11. Package Outline

SOT23-5L

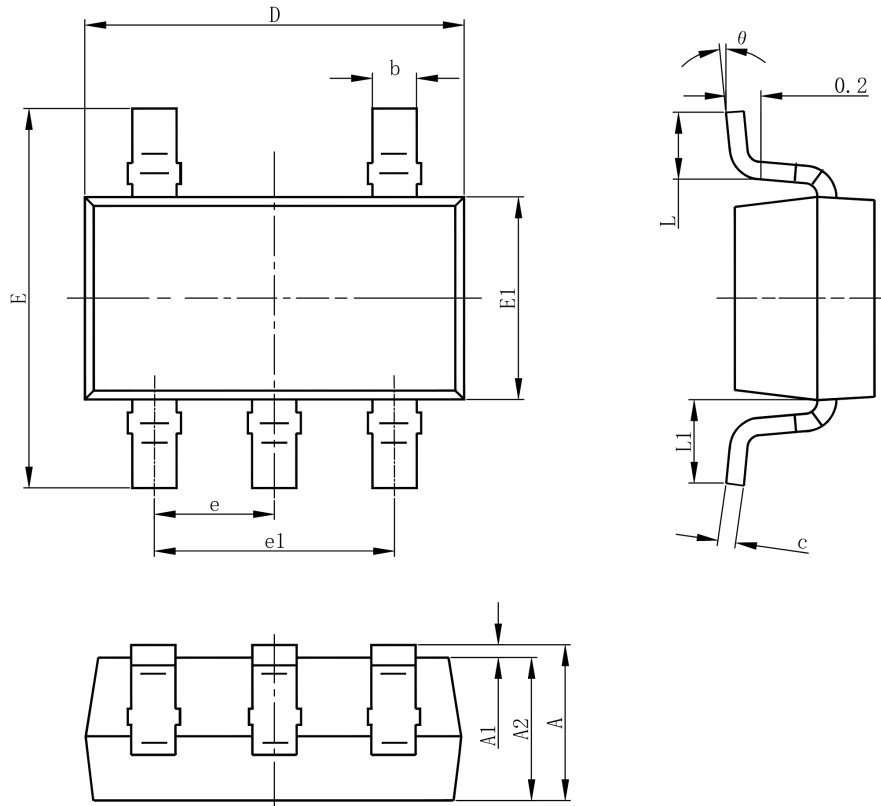

Symbol	Dimensions In Millimeters		Dimensions In Inches	
	Min.	Max.	Min.	Max.
A	1.050	1.250	0.041	0.049
A1	0.000	0.100	0.000	0.004
A2	1.050	1.150	0.041	0.045
b	0.300	0.500	0.012	0.020
c	0.100	0.200	0.004	0.008
D	2.820	3.020	0.111	0.119
E1	1.500	1.700	0.059	0.067
E	2.650	2.950	0.104	0.116
e	0.950(BSC)		0.037(BSC)	
e1	1.800	2.000	0.071	0.079
L	0.300	0.600	0.012	0.024
L1	0.600REF.		0.024REF.	
θ	0°	8°	0°	8°

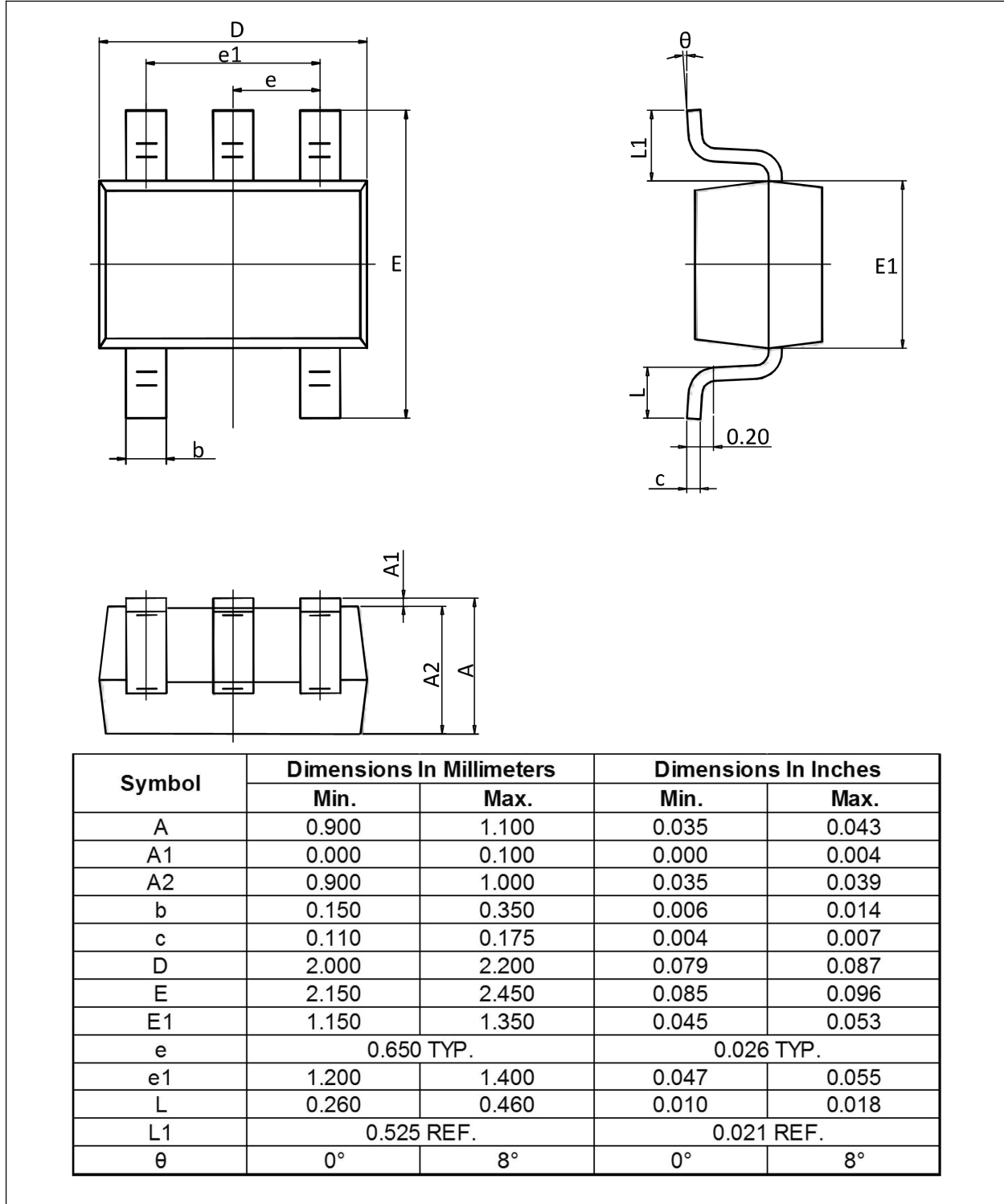
SOT353

SOT553

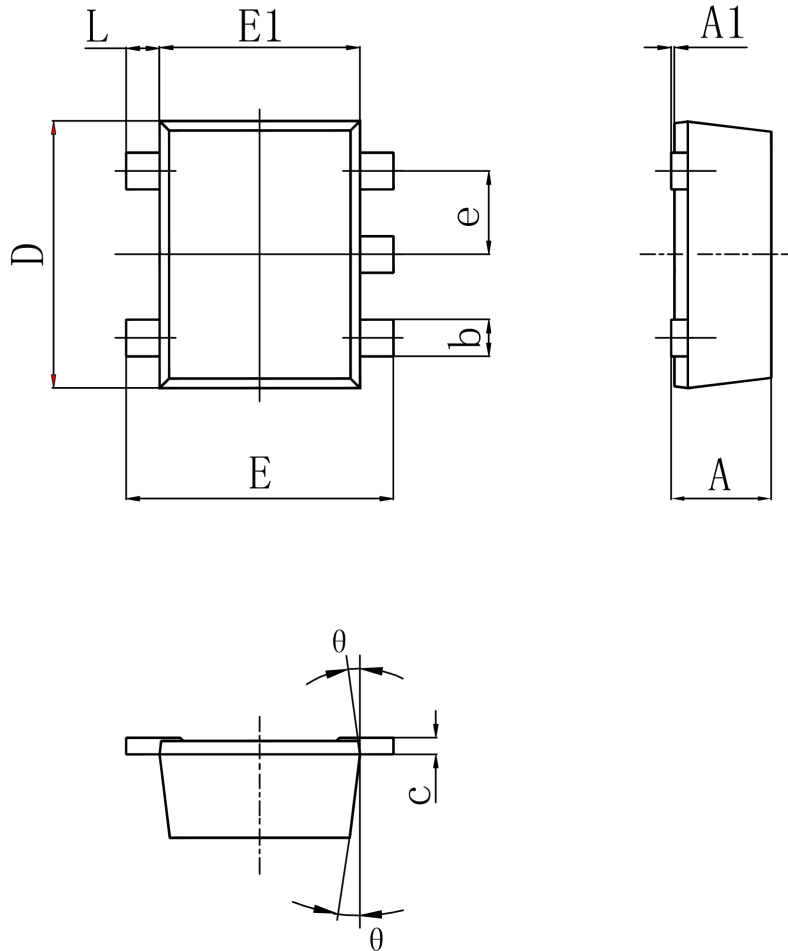

Symbol	Dimensions In Millimeters		Dimensions In Inches	
	Min.	Max.	Min.	Max.
A	0.525	0.600	0.021	0.024
A1	0.000	0.050	0.000	0.002
e	0.450	0.550	0.018	0.022
c	0.090	0.160	0.004	0.006
D	1.500	1.700	0.059	0.067
b	0.170	0.270	0.007	0.011
E1	1.100	1.300	0.043	0.051
E	1.500	1.700	0.059	0.067
L	0.100	0.300	0.004	0.012
θ	7 °REF.		7 °REF.	

12. Abbreviations

Table 10. Abbreviations

Acronym	Description
CMOS	Complementary Metal-Oxide Semiconductor
DUT	Device Under Test
ESD	ElectroStatic Discharge
HBM	Human Body Model
CDM	Charged Device Model
TTL	Transistor-Transistor Logic

13. Revision History

Table 11. Revision history

Document ID	Release Date	Data sheet status	Change notice	Supersedes
74AHC_AHCT1G04 Rev. 1.0	Aug 08, 2024	Product datasheet		