

Hex Buffer(Open Drain)

Features

- HIGH SPEED:
 $t_{PD} = 6ns$ (TYP.) at $V_{CC} = 6V$
- LOW POWER DISSIPATION:
 $I_{CC} = 1\mu A$ (MAX.) at $T_A=25^{\circ}C$
- HIGH NOISE IMMUNITY:
 $V_{NIH} = V_{NIL} = 28\% V_{CC}$ (MIN.)
- WIDE OPERATING VOLTAGE RANGE:
 V_{CC} (OPR) = 2V to 6V
- PIN AND FUNCTION COMPATIBLE WITH 74 SERIES 07

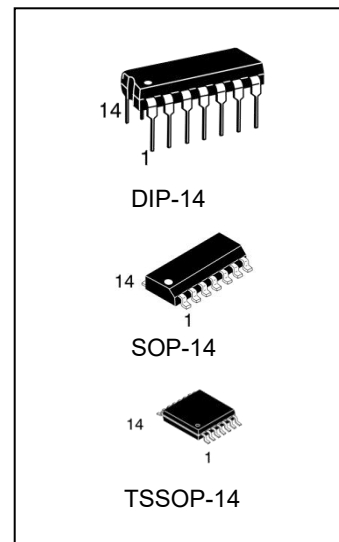

Ordering Information

DEVICE	Package Type	MARKING	Packing	Packing Qty
74HC07PG	DIP-14	74HC07	TUBE	1000pcs/box
74HC07DRG	SOP-14	74HC07	REEL	2500pcs/reel
74HC07DRG4	SOP-14	74HC07	REEL	4000pcs/reel
74HC07PWRG	TSSOP-14	HC07	REEL	2500pcs/reel

De Scription

The 74HC07 is an high speed CMOS HEX OPEN DRAIN BUFFER fabricated with silicon gate C²MOS technology.

The internal circuit is composed of 2 stages including buffer output, which enables high noise immunity and stable output.

All inputs are equipped with protection circuits against static discharge and transient excess voltage.

Pin Connection And Iec Logic Symbols

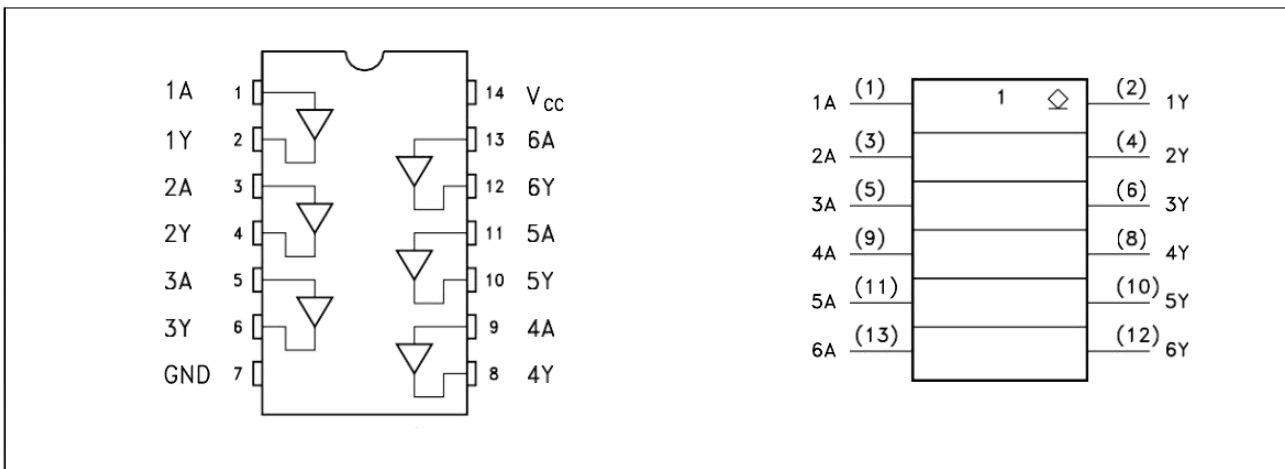

Pin Description

PIN No	SYMBOL	NAME AND FUNCTION
1, 3, 5, 9,11,13	1A to 6A	Data Inputs
2, 4, 6, 8,10,12	1Y to 6Y	Data Outputs
7	GND	Ground (0V)
14	V _{CC}	Positive Supply Voltage

Truth Table

A	Y
L	L
H	Z

ZZ:High Impedance

Input And Output Equivalent Circuit

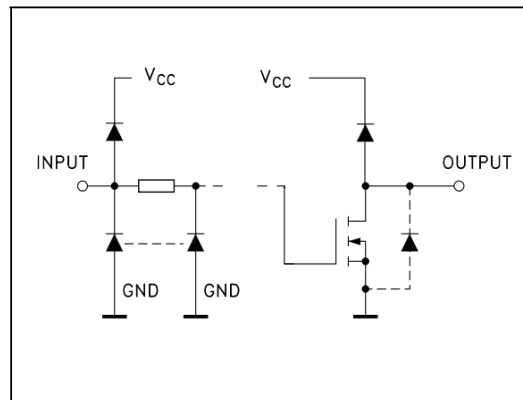

Absolute Maximum Ratings

Symbol	Parameter	Value	Unit
V _{CC}	Supply Voltage	-0.5 to +7	V
V _I	DC Input Voltage	-0.5 to V _{CC} + 0.5	V
V _O	DC Output Voltage	-0.5 to V _{CC} + 0.5	V
I _{IK}	DC Input Diode Current	20	mA
I _{OK}	DC Output Diode Current	20	mA
I _O	DC Output Current	25	mA
I _{CC} or I _{GND}	DC V _{CC} or Ground Current	50	mA
P _D	Power Dissipation	500(*)	mW
T _{stg}	Storage Temperature	-65 to +150	°C
T _L	Lead Temperature (10s)	245	°C

Absolute Maximum Ratings are those values beyond which damage to the device may occur. Functional operation under these conditions is not implied

(*) 500mW at 65°C; derate to 300mW by 10mW/°C from 65°C to 85°C

Recommended Operating Conditions

Symbol	Parameter	Value	Unit	
V _{CC}	Supply Voltage	2 to 6	V	
V _I	Input Voltage	0 to V _{CC}	V	
V _O	Output Voltage	0 to V _{CC}	V	
T _{op}	Operating Temperature	-40 to 85	°C	
t _r , t _f	Input Rise and Fall Time	V _{CC} = 2.0V	0 to 1000	ns
		V _{CC} = 4.5V	0 to 500	ns
		V _{CC} = 6.0V	0 to 400	ns

Dc Specifications

Symbol	Parameter	Test Condition		Value					Unit
		V _{CC} (V)		T _A = 25°C			-40 to 85°C		
				Min	Typ	Max	Min	Max	
V _{IH}	High Level Input Voltage	2.0		1.5			1.5		V
		4.5		3.15			3.15		
		6.0		4.2			4.2		
V _{IL}	Low Level Input Voltage	2.0				0.5		0.5	V
		4.5				1.35		1.35	
		6.0				1.8		1.8	
V _{OL}	Low Level Output Voltage	2.0	I _O =20μA		0.0	0.1		0.1	V
		4.5	I _O =20μA		0.0	0.1		0.1	
		6.0	I _O =20μA		0.0	0.1		0.1	
		4.5	I _O =4.0 mA		0.17	0.26		0.33	
		6.0	I _O =5.2 mA		0.18	0.26		0.33	
I _I	Input Leakage Current	6.0	V _I =V _{CC} or GND			0.1		1	μA
I _{OZ}	Output Leakage Current	6.0	V _I = V _{IH} or V _{IL} V _O =V _{CC} or GND			0.5		5	μA
I _{CC}	Quiescent Supply Current	6.0	V _I = V _{CC} or GND			1		10	μA

AC Electrical Characteristics(C_L=5pF, Input tr=tf=6ns)

Symbol	Parameter	Test Condition		Value					Unit
		V _{CC} (V)		T _A = 25°C			-40 to 85°C		
				Min.	Typ.	Max.	Min.	Max.	
t _{THL}	Output Transition Time	2.0			30	75		95	ns
		4.5			8	15		19	
		6.0			7	13		16	
t _{PLZ}	Propagation Delay Time	2.0	R _L = 1 KΩ		10	90		115	ns
		4.5			7	18		23	
		6.0			6	15		20	
t _{PZL}	Propagation Delay Time	2.0	R _L = 1 KΩ		17	90		115	ns
		4.5			7	18		23	
		6.0			5	15		20	

Capacitive Characteristics

Symbol	Parameter	Test Condition			Value					Unit
		V _{CC} (V)			T _A = 25°C			-40 to 85°C		
			Min.	Typ.	Max.	Min.	Max.			
C _{IN}	Input Capacitance	5.0			5	10		10	pF	
C _{OUT}	Output Capacitance	5.0			3				pF	
C _{PD}	Power Dissipation Capacitance (note 1)	5.0			4				pF	

C_{PD} is defined as the value of the IC's internal equivalent capacitance which is calculated from the operating current consumption without load. (Refer to Test Circuit). Average operating current can be obtained by the following equation. $I_{CC(opr)} = C_{PD} \times V_{CC} \times f_{IN} + I_{CC}/6$ (per gate)

Test Circuit

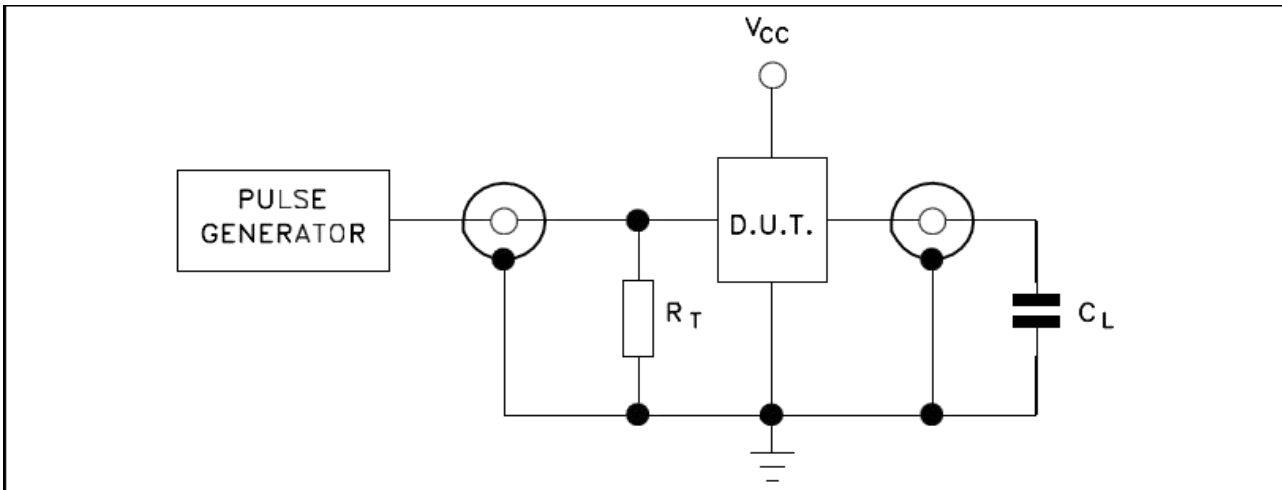

C_L = 50pF or equivalent (includes jig and probe capacitance)

R_T = Z_{OUT} of pulse generator (typically 50Ω)

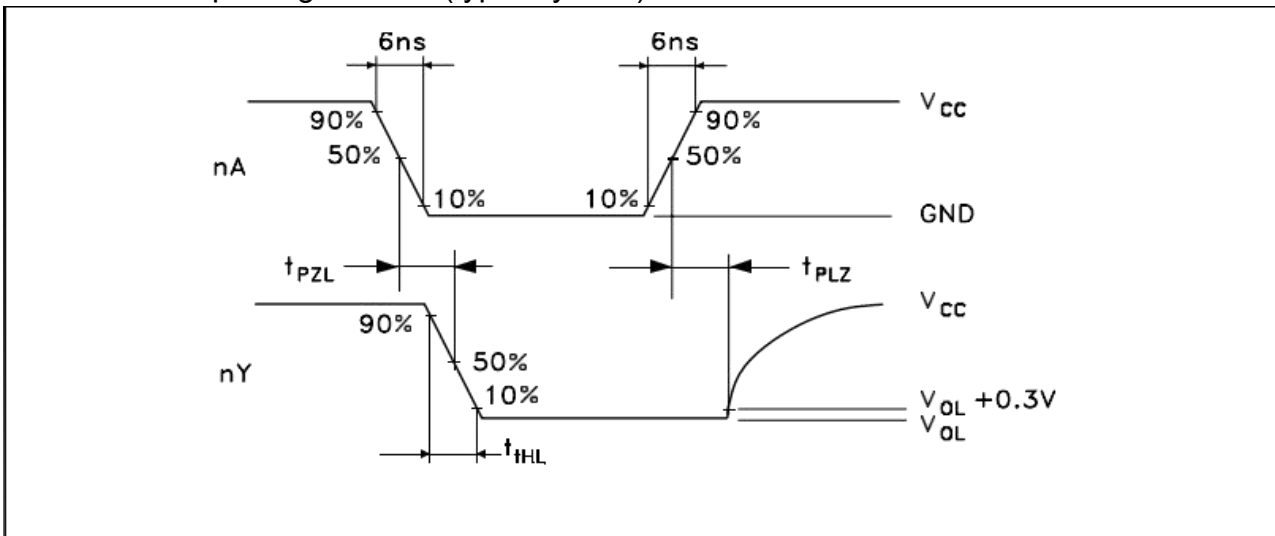

WAVEFORM: PROPAGATION DELAY TIME (f=1MHz; 50% duty cycle)

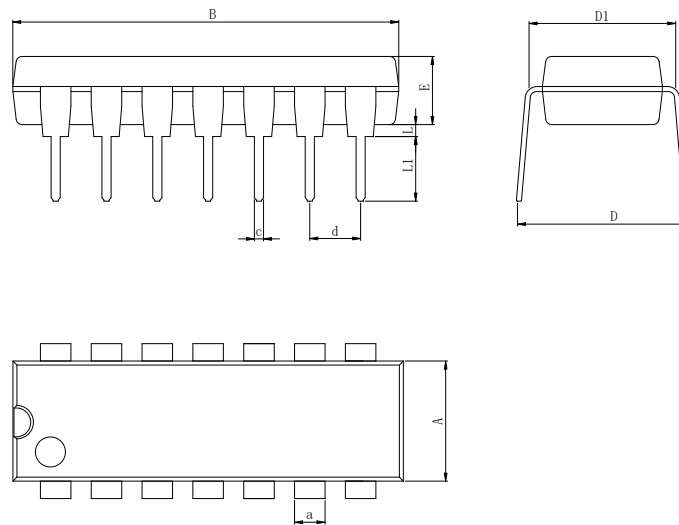
Physical Dimensions
DIP-14

Dimensions In Millimeters(DIP-14)

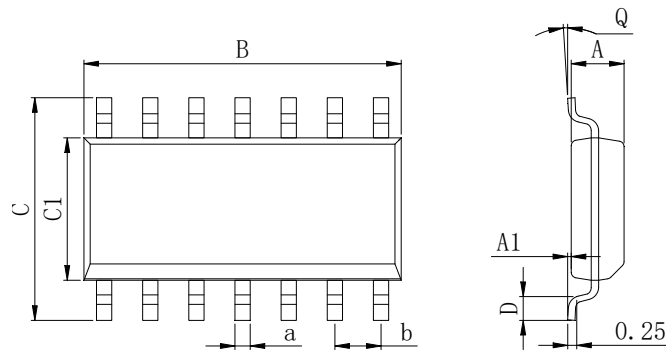
Symbol:	A	B	D	D1	E	L	L1	a	c	d
Min:	6.10	18.94	8.10	7.42	3.10	0.50	3.00	1.50	0.40	2.54 BSC
Max:	6.68	19.56	10.9	7.82	3.55	0.70	3.60	1.55	0.50	

SOP-14

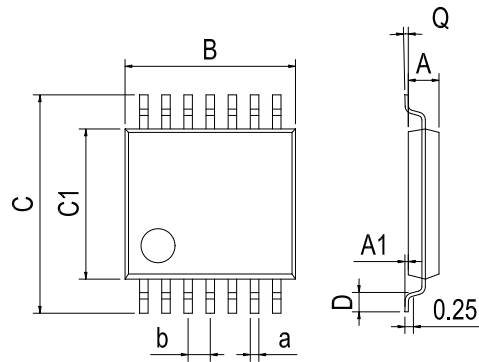
Dimensions In Millimeters(SOP-14)

Symbol:	A	A1	B	C	C1	D	Q	a	b
Min:	1.35	0.05	8.55	5.80	3.80	0.40	0°	0.35	1.27 BSC
Max:	1.55	0.20	8.75	6.20	4.00	0.80	8°	0.45	

TSSOP-14

Dimensions In Millimeters(TSSOP-14)

Symbol:	A	A1	B	C	C1	D	Q	a	b
Min:	0.85	0.05	4.90	6.20	4.30	0.40	0°	0.20	0.65 BSC
Max:	0.95	0.20	5.10	6.60	4.50	0.80	8°	0.25	

Revision History

REVISION NUMBER	DATE	REVISION	PAGE
V1.0	2019-3	New	1-9
V1.1	2023-9	Modify features and descriptions、 Update Lead Temperature、 Update encapsulation type、 Updated DIP-14 dimension、 Update Title	1、 3、 4、 6

IMPORTANT STATEMENT:

Hanschip Semiconductor reserves the right to change its products and services without notice. Before ordering, the customer shall obtain the latest relevant information and verify whether the information is up to date and complete. Hanschip Semiconductor does not assume any responsibility or obligation for the altered documents.

Customers are responsible for complying with safety standards and taking safety measures when using Hanschip Semiconductor products for system design and machine manufacturing. You will bear all the following responsibilities: select the appropriate Hanschip Semiconductor products for your application; Design, validate and test your application; Ensure that your application meets the appropriate standards and any other safety, security or other requirements. To avoid the occurrence of potential risks that may lead to personal injury or property loss.

Hanschip Semiconductor products have not been approved for applications in life support, military, aerospace and other fields, and Hanschip Semiconductor will not bear the consequences caused by the application of products in these fields. All problems, responsibilities and losses arising from the user's use beyond the applicable area of the product shall be borne by the user and have nothing to do with Hanschip Semiconductor, and the user shall not claim any compensation liability against Hanschip Semiconductor by the terms of this Agreement.

The technical and reliability data (including data sheets), design resources (including reference designs), application or other design suggestions, network tools, safety information and other resources provided for the performance of semiconductor products produced by Hanschip Semiconductor are not guaranteed to be free from defects and no warranty, express or implied, is made. The use of testing and other quality control technologies is limited to the quality assurance scope of Hanschip Semiconductor. Not all parameters of each device need to be tested.

The documentation of Hanschip Semiconductor authorizes you to use these resources only for developing the application of the product described in this document. You have no right to use any other Hanschip Semiconductor intellectual property rights or any third party intellectual property rights. It is strictly forbidden to make other copies or displays of these resources. You should fully compensate Hanschip Semiconductor and its agents for any claims, damages, costs, losses and debts caused by the use of these resources. Hanschip Semiconductor accepts no liability for any loss or damage caused by infringement.