

Product Summary

$V_{(BR)DSS}$	$R_{DS(on)TYP}$	I_D
120V	1.7mΩ@10V	345A



合肥矽普半导体

Siliup Semiconductor Technology Co., Ltd

技术 品质 服务

www.siliup.com

Feature

- Fast Switching
- Low Gate Charge and Rdson
- Low Reverse transfer capacitances
- 100% Single Pulse avalanche energy Test
- **AEC-Q101** quality

Applications

- High Speed Power switching
- DC-DC Converter
- Power Management

Package

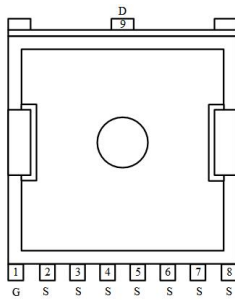

TOLL

Circuit diagram

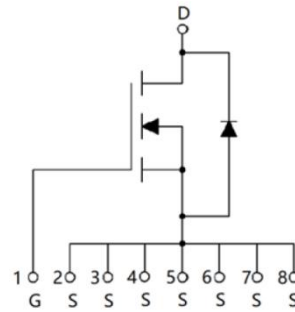

Marking

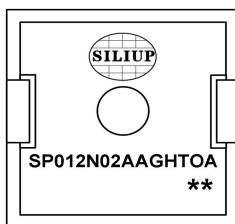

SP012N02AAGHTOA : Product code

** : Week code

Order Information

Device	Package	Unit/Tape
SP012N02AAGHTOA	TOLL	2000

Absolute maximum ratings (Ta=25°C unless otherwise noted)

Parameter	Symbol	Rating	Unit
Drain-Source Voltage	V _{DS}	120	V
Gate-Source Voltage	V _{GS}	±20	V
Continuous Drain Current1 (Tc=25°C)	I _D	345	A
Continuous Drain Current1 (Tc=100°C)	I _D	230	A
Pulsed Drain Current	I _{DM}	1380	A
Single Pulse Avalanche Energy ¹	E _{AS}	2916	mJ
Power Dissipation (Tc=25°C)	P _D	360	W
Power Dissipation (Tc=100°C)	P _D	180	W
Thermal Resistance Junction-to-Case	R _{θJC}	0.42	°C/W
Thermal Resistance Junction-to-Ambient	R _{θJA}	40	°C/W
Storage Temperature Range	T _{STG}	-55 to 175	°C
Operating Junction Temperature Range	T _J	-55 to 175	°C

Electrical characteristics (Ta=25°C, unless otherwise noted)

Characteristics	Symbol	Test Condition	Min	Typ	Max	Unit
Static Characteristics						
Drain-Source Breakdown Voltage	BV _{DSS}	ID=250μA , VGS=0V	120	135	-	V
Drain Cut-Off Current	IDSS	VDS=120V , VGS=0V	-	-	1	μA
Gate Leakage Current	IGSS	VGS=±20V , VDS=0V	-	-	±100	nA
Gate Threshold Voltage	V _{GS(th)}	VDS=VGS , ID=250μA	2.6	3.0	3.4	V
Drain-Source ON Resistance	R _{DS(ON)}	VGS=10V , ID=50A	-	1.7	2.25	mΩ
Gate Resistance	R _G	VDS=60V , VGS=0V , f=1MHz	-	5.4	-	Ω
Dynamic Characteristics						
Input Capacitance	C _{iss}	VDS=60V , VGS=0V , f=1.0MHz	-	14120	-	pF
Output Capacitance	C _{oss}		-	1260	-	
Reverse Transfer Capacitance	C _{rss}		-	84	-	
Total Gate Charge	Q _g	VDS=60V , VGS=10V , ID=100A	-	236	-	nC
Gate-Source Charge	Q _{gs}		-	66	-	
Gate-Drain Charge	Q _{gd}		-	62	-	
Gate Plateau Voltage	V _{plateau}		-	5	-	V
Switching Characteristics						
Turn-On Delay Time	t _{d(on)}	VDS=60V , VGS=10V , ID=100A , RG=1.6Ω	-	38	-	nS
Rise Time	t _r		-	30	-	
Turn-Off Delay Time	t _{d(off)}		-	86	-	
Fall Time	t _f		-	32	-	
Drain-Source Body Diode Characteristics						
Source-Drain Diode Forward Voltage	V _{SD}	IS=1A , VGS=0V , TJ=25°C	-	-	1.2	V
Maximum Body-Diode Continuous Current	IS		-	-	345	A
Reverse Recovery Time	T _{rr}	IS=100A , di/dt=100A/us , TJ=25°C	-	122	-	nS
Reverse Recovery Charge	Q _{rr}		-	312	-	nC

Note :

- The test condition is VDD=60V, VGS=10V, L=0.5mH, RG=25Ω

Typical Characteristics

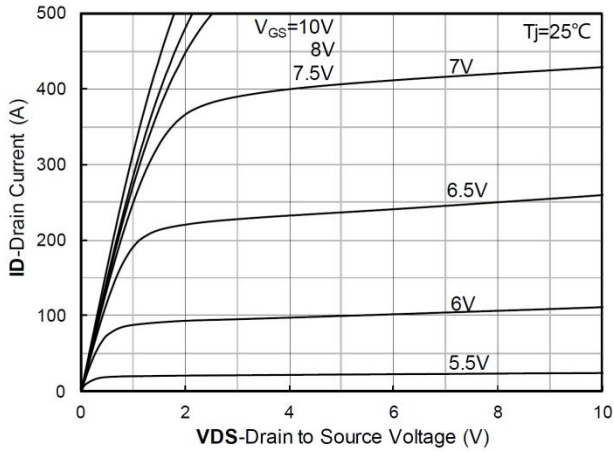

Output Characteristics

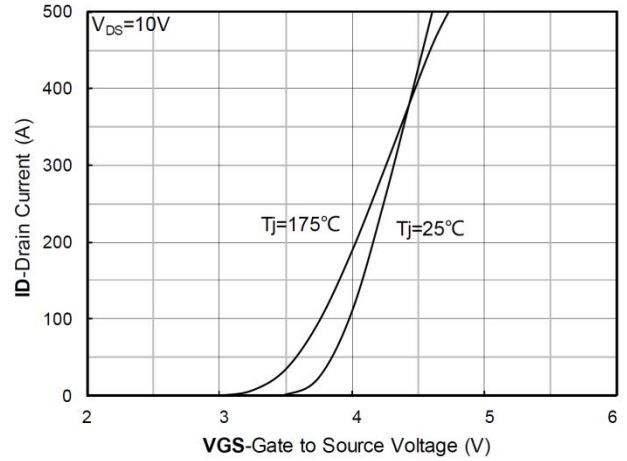

Transfer Characteristics

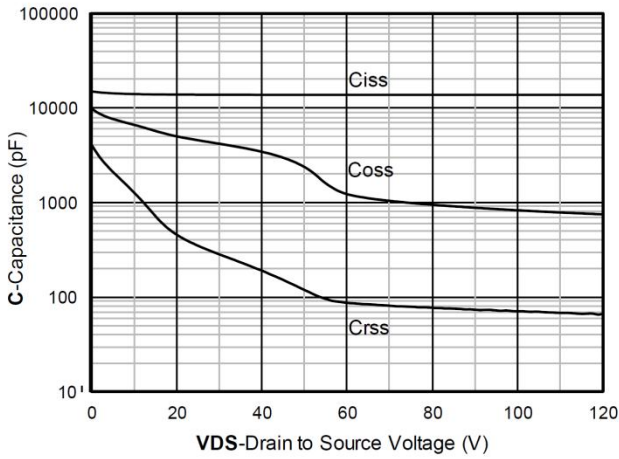

Capacitance Characteristics

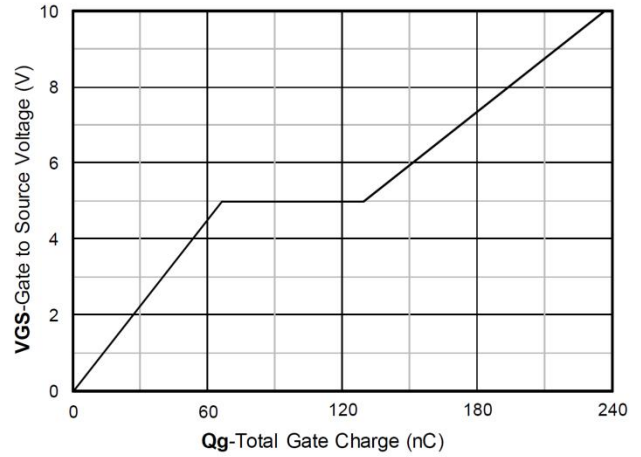

Gate Charge

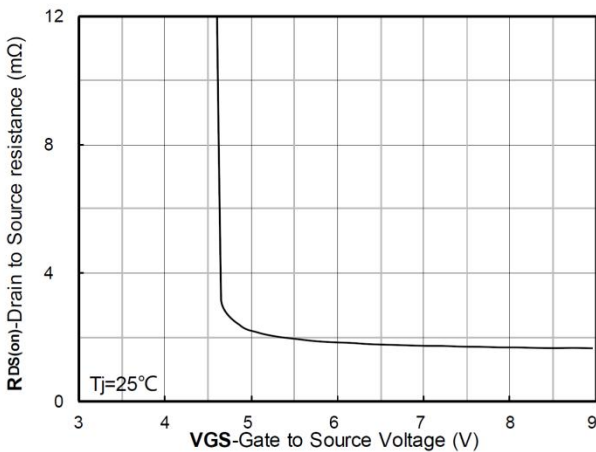

On-Resistance vs. Gate to Source Voltage

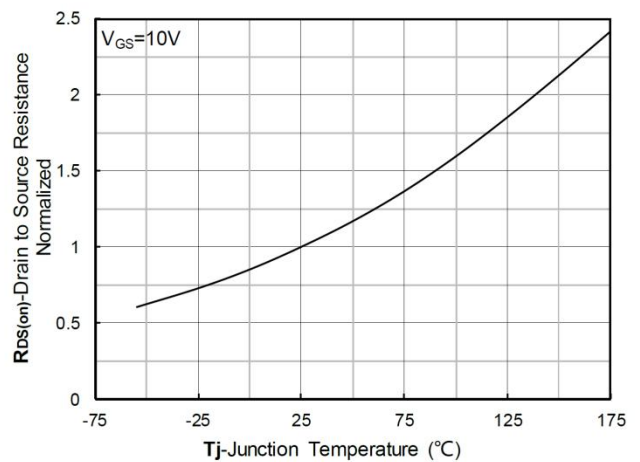

Normalized On-Resistance

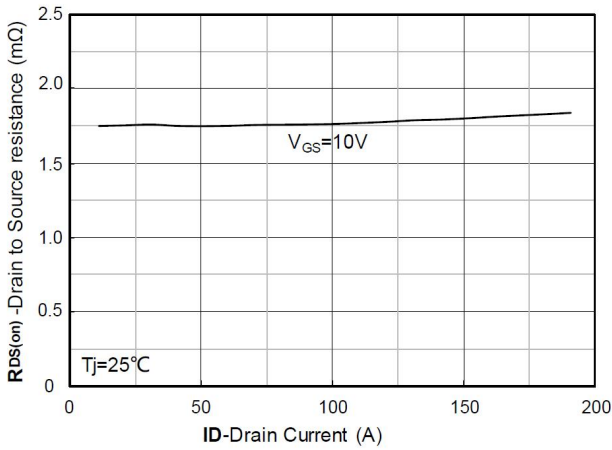

RDS(on) vs. Drain Current

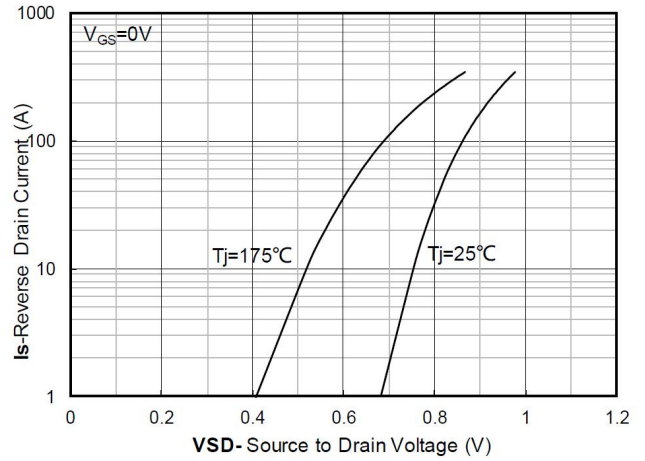

Forward characteristics of reverse diode

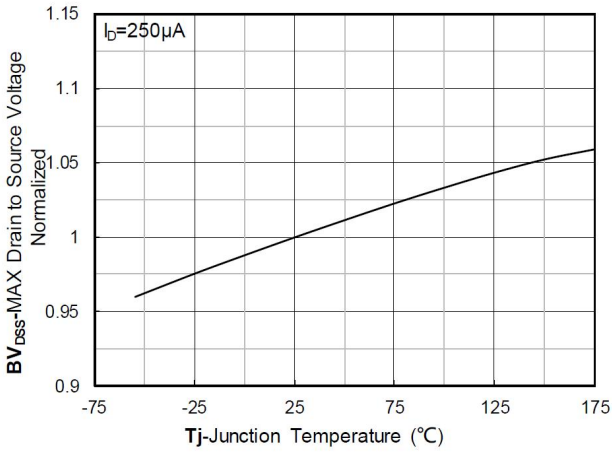

Normalized breakdown voltage

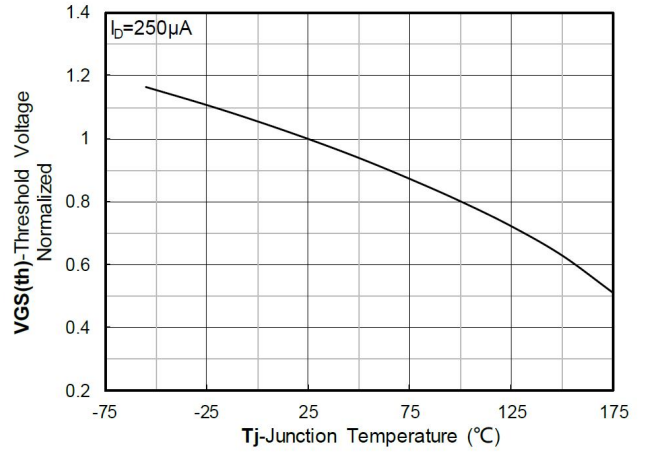

Normalized Threshold voltage

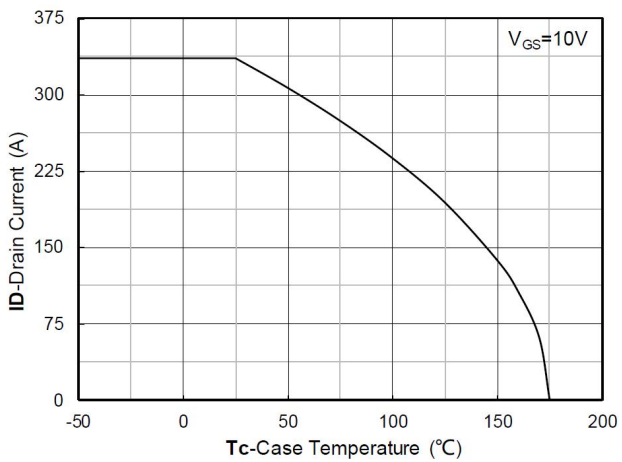

Current dissipation

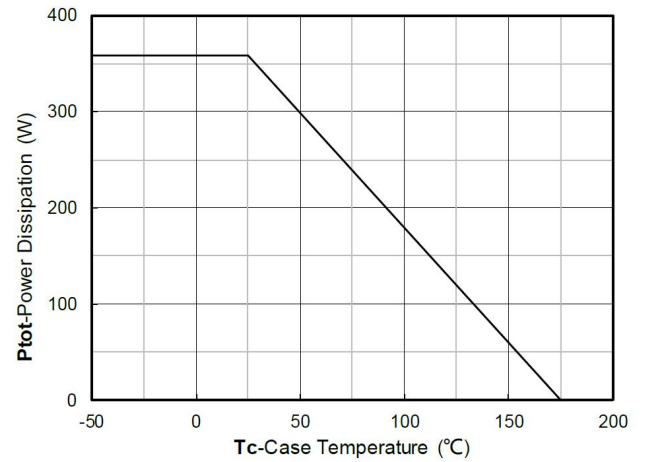

Power dissipation

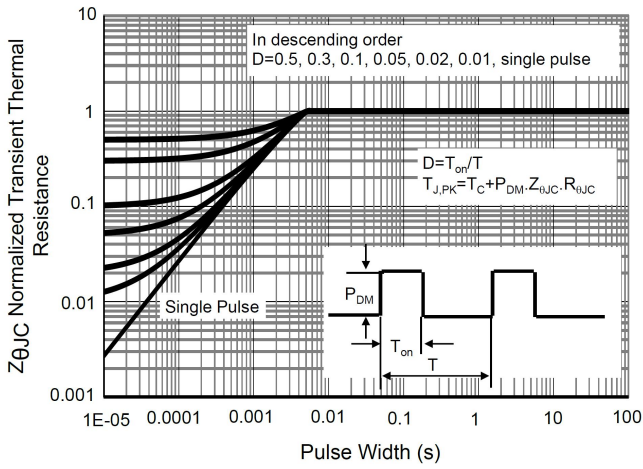

Normalized Maximum Transient Thermal Impedance

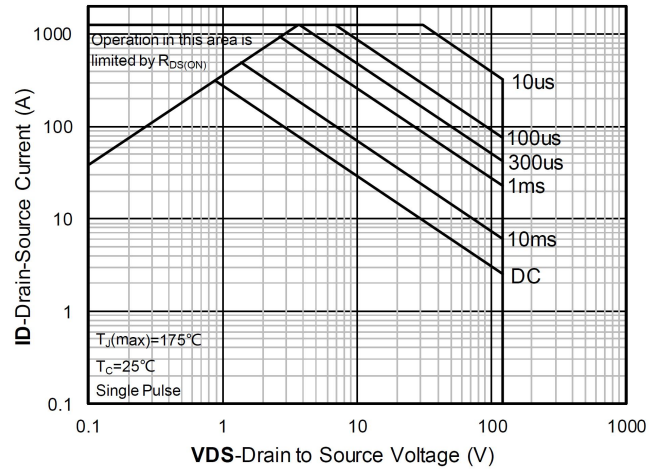

Safe Operation Area

Test Circuit

Gate Charge

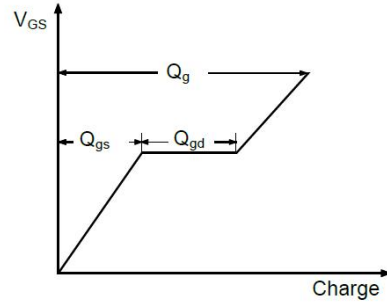
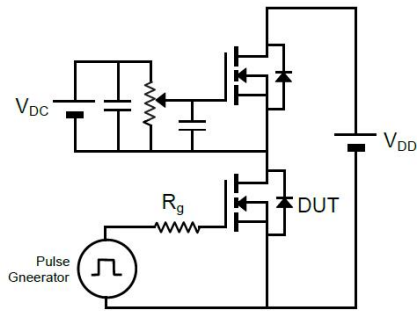

Resistive Load Switching Time

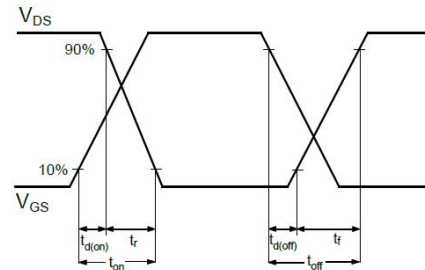
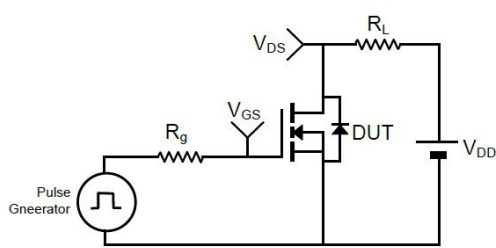

Un-clamped Inductive Load Switching

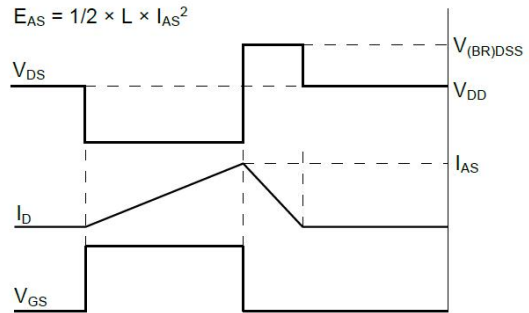
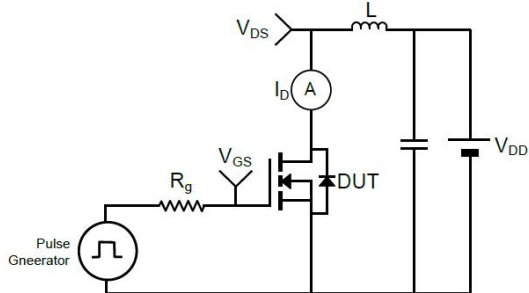

Drain-Source Body Diode Reverse Recovery

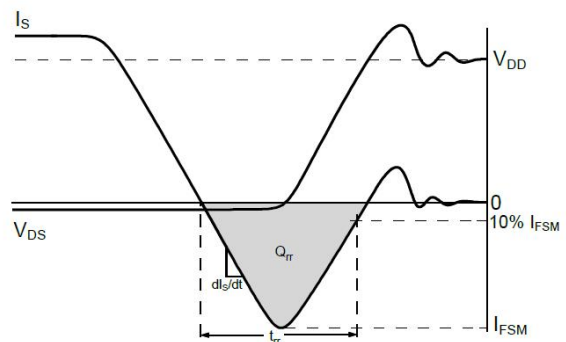
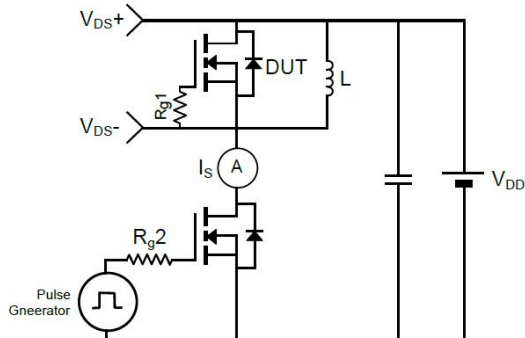

Temperature Profile for IR Reflow Soldering

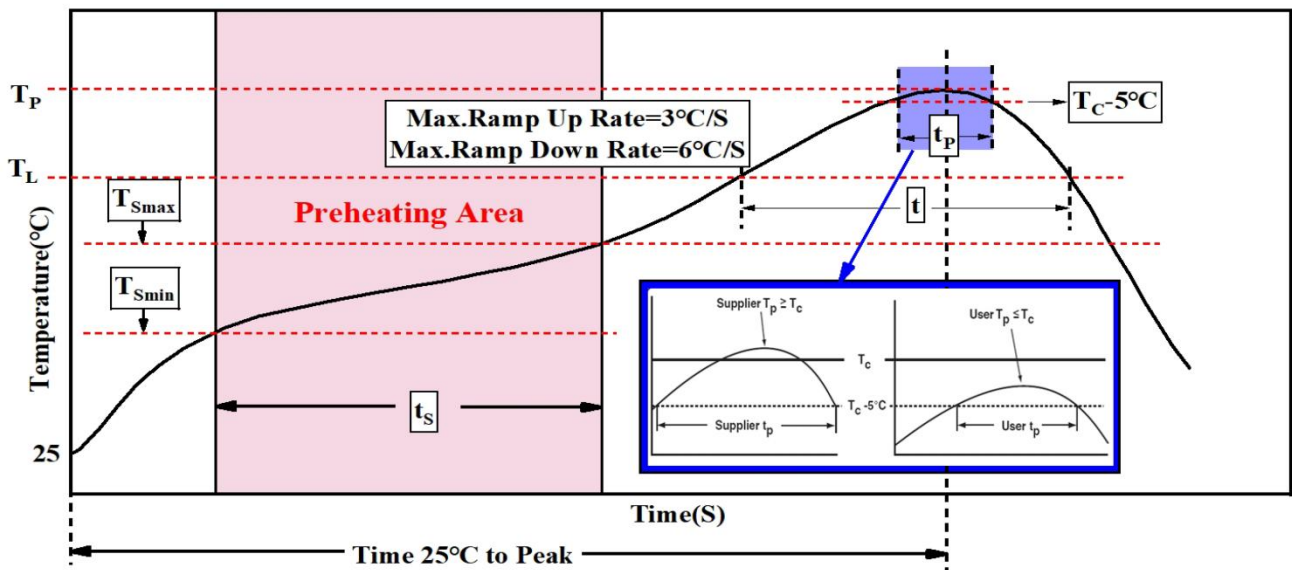

Profile Feature	Sn-Pb Eutectic Assembly	Pb-Free Assembly
Preheat & Soak		
Temperature min (T _{smin})	100°C	150°C
Temperature max (T _{smax})	150°C	200°C
Time (T _{smin} to T _{smax}) (t _s)	60-120 seconds	60-120 seconds
Average ramp-up rate (T _{smax} to T _p)	3 °C/second max.	3°C/second max.
Liquidous temperature (T _L)	183 °C	217°C
Time at liquidous (t _L)	60-150 seconds	60-150 seconds
Peak package body Temperature e (T _p)*	See Classification Temp in table 1	See Classification Temp in table 2
Time (t _p)** within 5°C of the specified classification temperature (T _c)	20** seconds	30** seconds
Average ramp-down rate (T _p to T _{smax})	6 °C/second max.	6 °C/second max.
Time 25°C to peak temperature	6 minutes max.	8 minutes max.
* Tolerance for peak profile Temperature (T _p) is defined as a supplier minimum and a user maximum. ** Tolerance for time at peak profile temperature (t _p) is defined as a supplier minimum and a user maximum		

Table 1. SnPb Eutectic Process – Classification Temperatures (T_c)

Package Thickness	Volume mm ³ <350	Volume mm ³ ≥350
<2.5 mm	235 °C	220 °C
≥2.5 mm	220 °C	220 °C

Table 2. Pb-free Process – Classification Temperatures (T_c)

Package Thickness	Volume mm ³ <350	Volume mm ³ 350-2000	Volume mm ³ >2000
<1.6 mm	260 °C	260 °C	260 °C
1.6 mm – 2.5 mm	260 °C	250 °C	245 °C
≥2.5 mm	250 °C	245 °C	245 °C

TOLL Reel Information

REEL DIMENSIONS

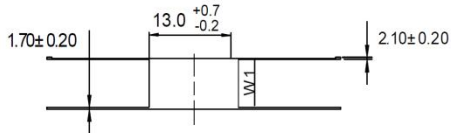
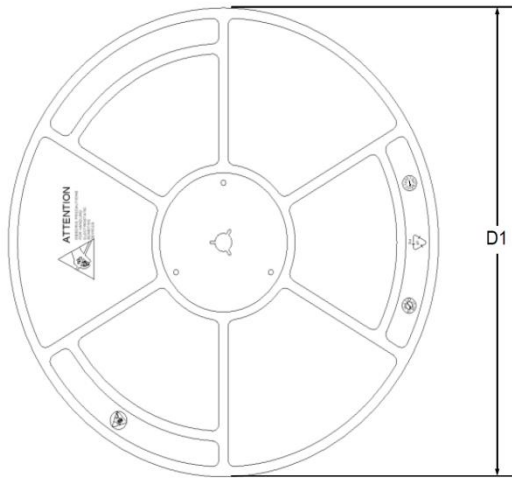

TAPE DIMENSIONS

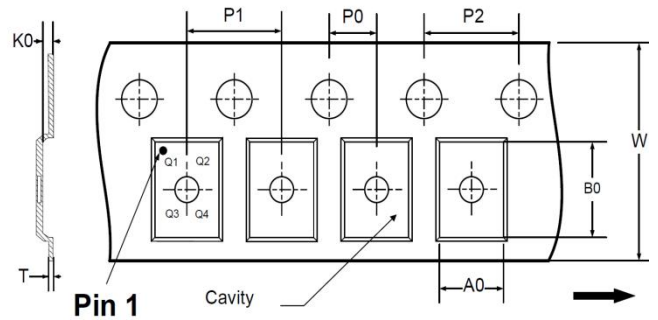

- A0: Dimension designed to accommodate the component width
- B0: Dimension designed to accommodate the component length
- K0: Dimension designed to accommodate the component thickness
- W: Overall width of the carrier tape
- P0: Pitch between successive cavity centers and sprocket hole
- P1: Pitch between successive cavity centers
- P2: Pitch between sprocket hole
- T: Tape material thickness
- D1: Reel Diameter
- W1: Reel Width

		DIMENSIONS								(Unit: mm)	
Reel	D1	W1								Material	
	330	24.4								Hips	
Tape	P0	P1	P2	W	A0	B0	K0	T	Pin 1 Quadrant	Material	
	2	4	12	24	10.3	12.1	2.6	0.35	Q1	PC	

All dimensions are nominal

TOLL Package Information

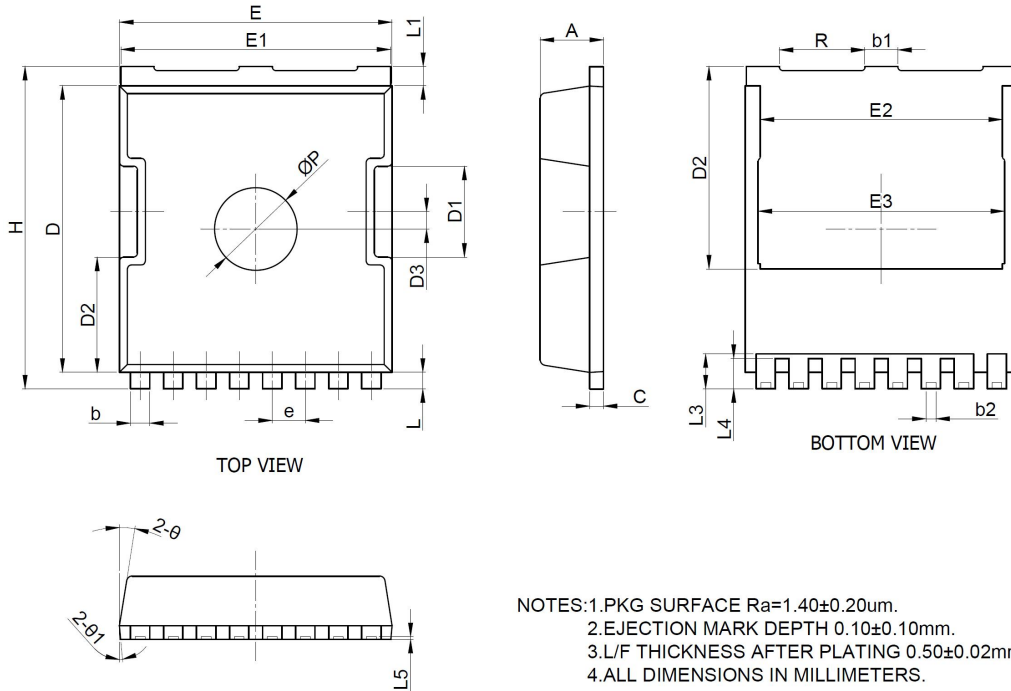

NOTES: 1.PKG SURFACE Ra=1.40±0.20um.
 2.EJECTION MARK DEPTH 0.10±0.10mm.
 3.L/F THICKNESS AFTER PLATING 0.50±0.02mm.
 4.ALL DIMENSIONS IN MILLIMETERS.

Symbol	Dimensions In Millimeters		
	Min.	Nom.	Max.
A	2.20	2.30	2.40
b	0.60	0.70	0.80
b1	1.10	1.20	1.30
b2	0.36 REF.		
C	0.40	0.50	0.60
D	10.30	10.40	10.50
D1	3.20	3.30	3.40
D2	4.08	4.18	4.28
D3	0.53	0.63	0.73
D4	7.35 REF.		
E	9.80	9.9	10.00
E1	9.70	9.80	9.90
E2	8.80 REF.		
E3	8.95 REF.		
e	1.20 BSC.		
H	11.5	11.7	11.90
L	0.5	0.6	0.7
L1	0.60	0.7	0.80
L2	0.10 REF.		
L3	1.27 REF.		
L4	1.10 REF.		
P	2.00	3.00	4.00
R	3.00	3.10	3.20
θ	7°	9°	11°
θ1	3°	5°	7°