



EVL4247-V-00A

36V, 100W Buck-Boost with Integrated Low-Side MOSFETS and I²C Interface Evaluation Board

DESCRIPTION

The EVL4247-V-00A is an evaluation board designed for the MP4247, a buck-boost converter with two low-side, integrated power MOSFETs. The device can deliver up to 100W of peak output power at a certain input supply range with excellent efficiency.

The MP4247 is well-suited for USB power delivery (PD) applications. The device can work with external USB PD controllers through the I²C interface. The I²C interface and one-time-programmable (OTP) memory provide flexibility for configurable features.

Fault protections include constant current (CC) current limiting, output over-voltage protection (OVP), and thermal shutdown (TSD).

The MP4247 requires a minimal number of readily available, standard external components. The MP4247 is available in a QFN-20 (3mmx5mm) package.

ELECTRICAL SPECIFICATIONS

Parameter	Symbol	Value	Units
Typical input voltage	V _{IN}	12	V
Maximum input voltage	V _{IN_MAX}	36	V
Switching frequency	f _{SW}	420	kHz
Default output voltage ⁽¹⁾	V _{OUT}	5	V
Output current	I _{OUT}	5	A
Default operation status	-	On	-

Note:

1) The default output voltage (V_{OUT}) is 0.5V. Change V_{OUT} via VOUT_COMMAND, or adjust the resistor dividers at the FB pin.

FEATURES

- 100W Buck-Boost Converter with Integrated Low-Side MOSFETS
- Integrated Gate Driver for High-Side Power Switches
- 3.6V to 36V Start-Up Input Voltage Range
- Supports 2.8V Falling V_{IN} when V_{OUT} > 3.5V
- 1V to 24V Output Voltage Range with 1% Accuracy
- Up to 5A Output Current
- Up to 98% Peak Efficiency
- Configurable 0.1V to 2.147V V_{REF} Range with 1mV Resolution via the I²C
- Accurate Output CC Current Limit: ±5%
- Meets USB-PD 3.0 with PPS Specification
- Selectable 280kHz, 420kHz, or 600kHz Switching Frequency
- Selectable Forced PWM Mode or Auto PFM/PWM Mode
- Output Biased VCC LDO for Higher Efficiency
- Output Current Monitoring (IMON)
- Line Drop Compensation via R_{SENSE}
- I²C, Alert and One-Time Programmable (OTP) Memory
- EN Shutdown Passive Discharge
- Output OCP, OVP and Thermal Shutdown Protection
- Available in a QFN-20 (3mmx5mm) Package

 Optimized Performance with MPS Inductor MPL-AY1050 Series

APPLICATIONS

- USB-C and USB Power Delivery
- USB-C and USB-A Communication Interfaces
- USB-C Car Chargers
- Wireless Charging

All MPS parts are lead-free, halogen-free, and adhere to the RoHS directive. For MPS green status, please visit the MPS website under Quality Assurance. "MPS", the MPS logo, and "Simple, Easy Solutions" are trademarks of Monolithic Power Systems, Inc. or its subsidiaries.

EVL4247-V-00A EVALUATION BOARD

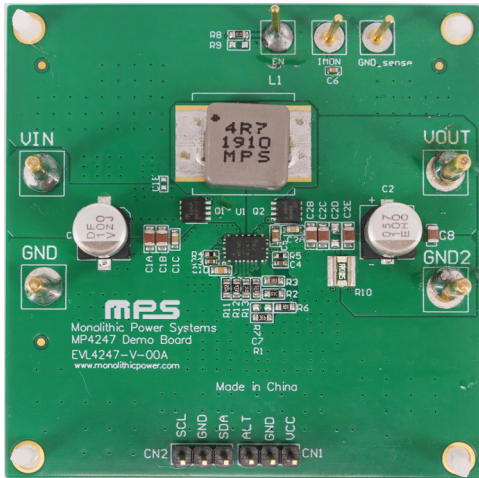

LxW (6.4cmx6.4cm) (4-Layer PCB)

Board Number	MPS IC Number	MPS Inductor Number
EVL4247-V-00A	MP4247GQV-0000	MPL-AY1050-4R7

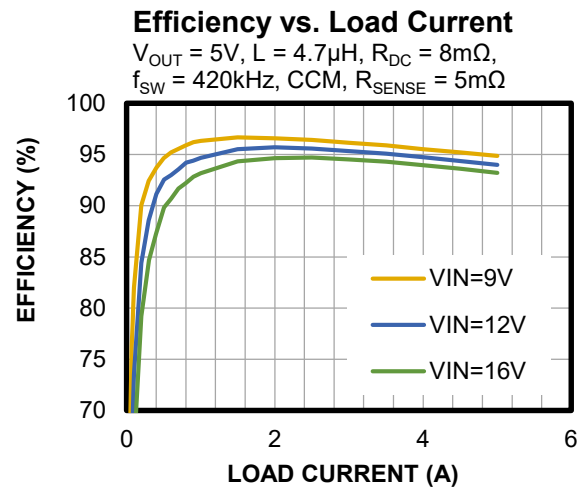

MP4247GQV-0000 CONFIGURATION TABLE

OTP Items	Description	Value
Operation	Sets the MP4247 to the on or off state.	1: On
Output Voltage (V)	Sets the output voltage.	5V
Dither Enable	Enables frequency spread spectrum (FSS).	0: Disabled (default)
Frequency	Sets the switching frequency.	01: 420kHz (default)
SWA FET On Resistance	Sets the external switching FET A's on resistance when under 5V _{GS} .	01: 10mΩ
Output OVP Enable	Enables output OVP.	1: Enabled (default)
Output Discharge Enable	Enables the output discharge function during the V _{IN} , I ² C, and EN off period.	1: Enabled (default)
PFM/PWM Mode	Sets auto PFM/PWM or forced PWM mode.	1: Forced PWM mode (default)
LDC Disable	Enables line drop compensation.	0: Enable line drop compensation (default)
Current Limit	Sets the output current limit.	5.4A
Line Drop Compensation Gain	Sets the output voltage compensation value vs. load current.	00: No compensation (default)
Switching Current Limit	Sets the SWB valley current limit and SWC peak current limit.	10: SWC peak 15A/SWB valley 13A (default)
R _{SENSE}	Selects the R _{SENSE} value.	0: 5mΩ (default)
Slew Rate Rise	Sets the V _{REF} adjusting rising slew rate. The V _{OUT} slew rate = V _{REF} slew rate x feedback ratio, where the feedback ratio = 10.	01: 0.16mV/μs (default)
Slew Rate Fall	Sets the V _{REF} adjusting falling slew rate. The V _{OUT} slew rate = V _{REF} slew rate x feedback ratio, where the feedback ratio = 10.	01: 0.04mV/μs (default)
Frequency Mode	Sets the frequency mode under buck-boost conditions.	0: Reduce the frequency by half compared to buck and boost mode (default)
SW2 Edge	Selects the SW2 rising and falling speed.	1: Faster (default)
I ² C Address	Sets the I ² C slave address.	67h
VOUT Mask	Masks the ALT pin indication.	1: Masked
IOUT/POUT Mask		0: Not masked
RESERVED Mask		1: Masked
TEMP Mask		1: Masked
PG_STATUS# Mask		1: Masked
PG_ALT_EDGE Mask		1: Masked
RESERVED Mask		1: Masked
UNKNOWN Mask		1: Masked

Note:

2) To customize the one-time programmable (OTP), work with an MPS FAE to create a unique suffix code.

QUICK START GUIDE

1. Connect the load terminals to:
 - a. Positive (+): VOUT
 - b. Negative (-): GND2
2. Preset the power supply output to 12V, then turn the power supply off.
3. Connect the power supply output terminals to:
 - a. Positive (+): VIN
 - b. Negative (-): GND
4. Turn the power supply on. V_{OUT} should start up automatically.
5. V_{OUT} is set to 5V by default. The reference voltage of FB is 0.5V. Adjust V_{OUT} by changing VOUT_COMMAND (0x21) or adjusting the resistor divider on the FB pin.
6. The constant current (CC) limit is 5.4A by default. To obtain the target limit, adjust the constant current limit by changing MFR_CURRENT_LIMIT (0xD1).
7. Download MPS's GUI from the MPS website. Open the GUI, and it should automatically update to the latest version.

EVALUATION BOARD SCHEMATIC

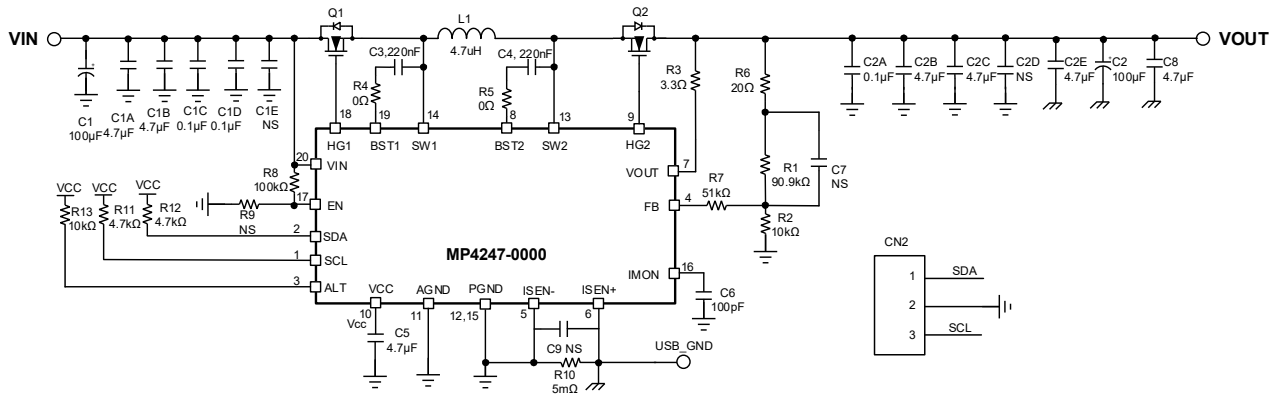

Figure 1: Evaluation Board Schematic

EVL4247-V-00A BILL OF MATERIALS

Qty	Ref	Value	Description	Package	Manufacturer	Manufacturer P/N
1	U1	MP4247	Buck-boost converter with low-side MOSFETs	QFN-20 (3mmx5mm)	MPS	MP4247GQV-0000
1	L1	4.7μH	Inductor, R _{DC} = 9.5mΩ, I _{SAT} = 15A	1050	MPS	MPL-AY1050-4R7
1	C1	100μF	100μF/35V	SMD	Nippon Chemi-Con	EMZJ350ADA101MF80G
1	C2	100μF	25V, hybrid, 20mΩ	SMD	Chemi-Con	HHXC250ARA101MF80G
3	C1C, C1D, C2A	100nF	Ceramic capacitor, 50V, X7R	0603	Samsung	CL05B104KB5NNNC
6	C1A, C1B, C2B, C2C, C2E, C8	4.7μF	Ceramic capacitor, 50V, X5R	0805	TDK	CGA4J1Z7R1H475K
2	C3, C4	220nF	Ceramic capacitor, 16V, X7R	0402	Murata	GRM155R71C224KA12D
0	C7, C9, R9	NS				
1	C5	4.7μF	Ceramic capacitor, 10V, X7S	0603	Murata	GRM188C71A475KE11D
1	C6	100pF	Ceramic capacitor, 25V, X7R	0402	Murata	GRM1555C1E101JA01D
1	R1	90.9kΩ	Film resistor, 1%, 0603, 90.9kΩ	0603	Yageo	RC0603FR-0790K9L
2	R2, R13	10kΩ	Film resistor, 10kΩ, 1%	0603	Yageo	RC0603FR-0710KL
1	R3	3.3Ω	Film resistor, 3.3Ω, 1%	0603	Yageo	RC0603FR-073R3L
2	R4, R5	0Ω	Film resistor, 0Ω, 1%	0402	Yageo	RC00402FR-070L
1	R6	20Ω	Film resistor, 1%, 20Ω	0603	Yageo	RC0603FR-0720RL
1	R7	51kΩ	Film resistor, 1%, 0603, 51kΩ	0603	Yageo	RC0603FR-0751KL
1	R8	100kΩ	Film resistor, 1%, 0603, 100kΩ	0603	Yageo	RC0603FR-07100KL
1	R10	0.005Ω	1%, long side, 1W, current-sense resistor	1508	Film Tech	RL3720WT-R005-F
2	R11, R12	4.7kΩ	Film resistor, 4.7kΩ, 1%	0603	Yageo	RC0603FR-074K7L
2	Q1, Q2	AONR66 406	40V, 9.4mΩ, 30A, 8.5nC, N-channel MOSFET	DFN (3x3) EP	AOS	AONR66406
1	CN2	3 pin	3 pins, 1 row, straight	DIP	Würth	61300311121

TYPICAL CHARACTERISTICS

V_{IN} = 12V, V_{OUT} = 5V, L = 4.7μH, f_{SW} = 420kHz, forced PWM mode, T_A = 25°C, unless otherwise noted.

Efficiency vs. Load Current

V_{OUT} = 5V, L = 4.7μH, R_{DC} = 8mΩ, f_{SW} = 420kHz, CCM, R_{SENSE} = 5mΩ

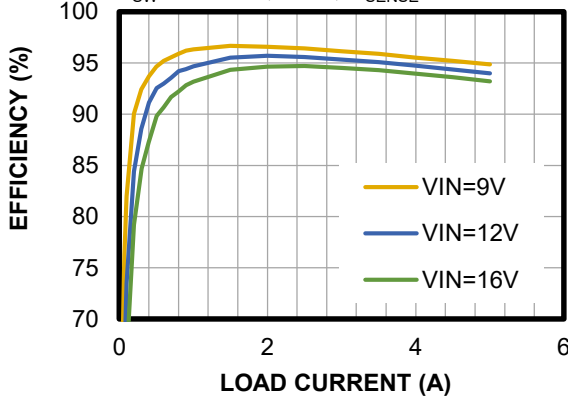

Efficiency vs. Load Current

V_{OUT} = 12V, L = 4.7μH, R_{DC} = 8mΩ, f_{SW} = 420kHz, CCM, R_{SENSE} = 5mΩ

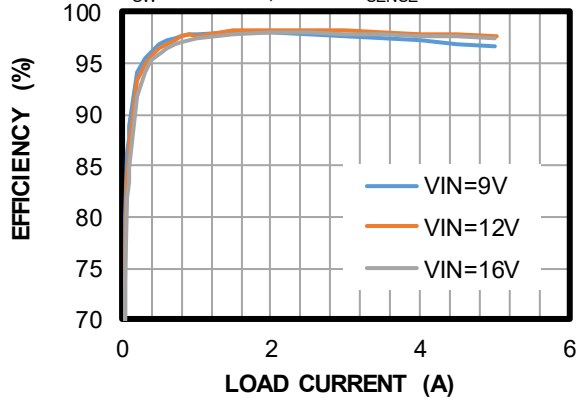

Efficiency vs. Load Current

V_{OUT} = 9V, L = 4.7μH, R_{DC} = 8mΩ, f_{SW} = 420kHz, CCM, R_{SENSE} = 5mΩ

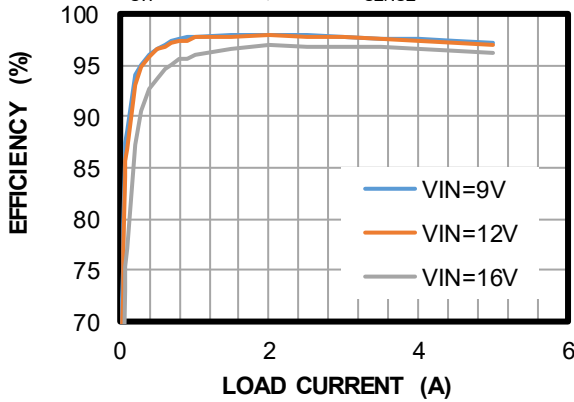

Efficiency vs. Load Current

V_{OUT} = 15V, L = 4.7μH, R_{DC} = 8mΩ, f_{SW} = 420kHz, CCM, R_{SENSE} = 5mΩ

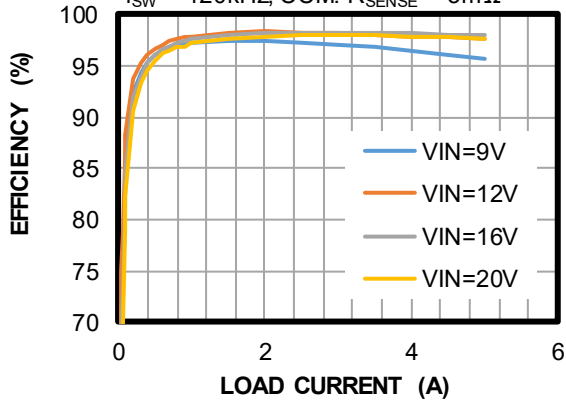

Efficiency vs. Load Current

V_{OUT} = 20V, L = 4.7μH, R_{DC} = 8mΩ, f_{SW} = 420kHz, CCM, R_{SENSE} = 5mΩ

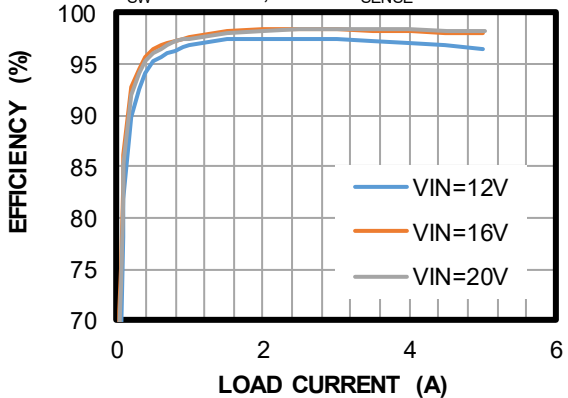

Case Temperature Rise

V_{IN} = 12V, V_{OUT} = 5V, f_{SW} = 420kHz, based on 6cmx6cm board. L = 4.7μH, R_{DC} = 8mΩ

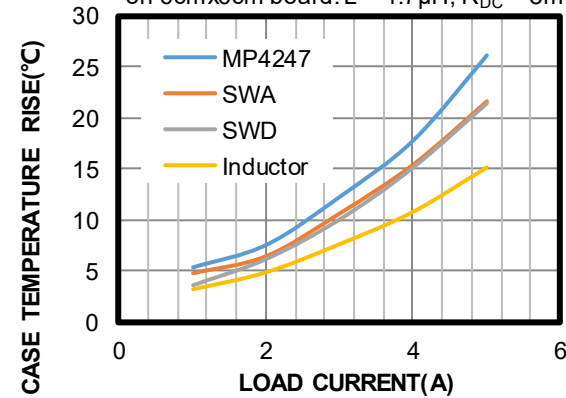

TYPICAL CHARACTERISTICS (continued)

V_{IN} = 12V, V_{OUT} = 5V, L = 4.7μH, f_{sw} = 420kHz, forced PWM mode, T_A = 25°C, unless otherwise noted.

Case Temperature Rise

V_{IN} = 12V, V_{OUT} = 12V, f_{sw} = 420kHz, based on 6cmx6cm board. L = 4.7μH, R_{DC} = 8mΩ

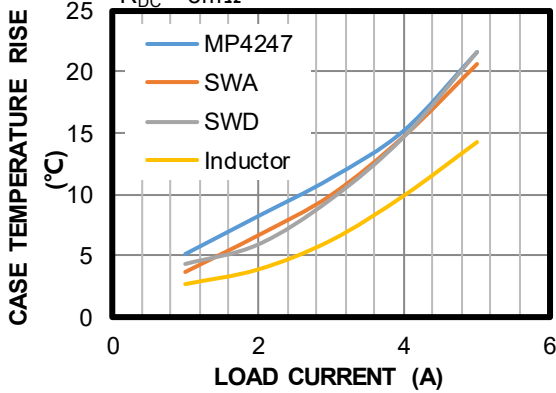

Case Temperature Rise

V_{IN} = 12V, V_{OUT} = 20V, f_{sw} = 420kHz, based on 6cmx6cm board. L = 4.7μH, R_{DC} = 8mΩ

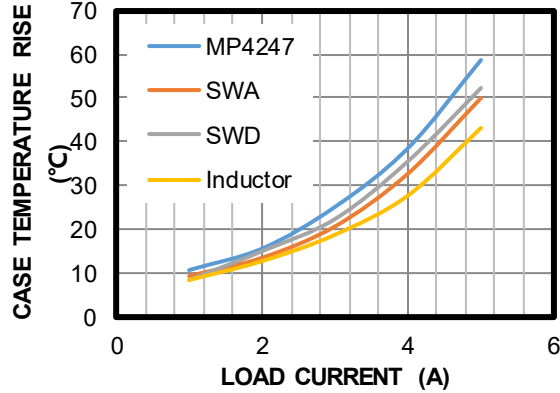

Case Temperature Rise

V_{IN} = 19V, V_{OUT} = 5V, f_{sw} = 420kHz, based on 6cmx6cm board. L = 4.7μH, R_{DC} = 8mΩ

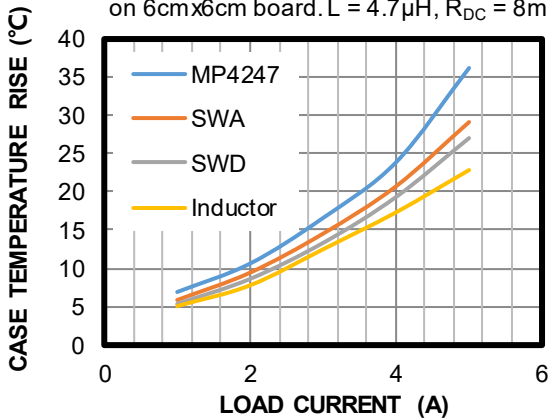

Case Temperature Rise

V_{IN} = 19V, V_{OUT} = 9V, f_{sw} = 420kHz, based on 6cmx6cm board. L = 4.7μH, R_{DC} = 8mΩ

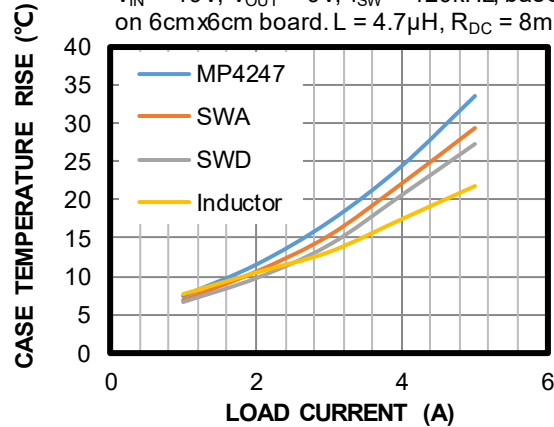

Case Temperature Rise

V_{IN} = 19V, V_{OUT} = 15V, f_{sw} = 420kHz, based on 6cmx6cm board. L = 4.7μH, R_{DC} = 8mΩ

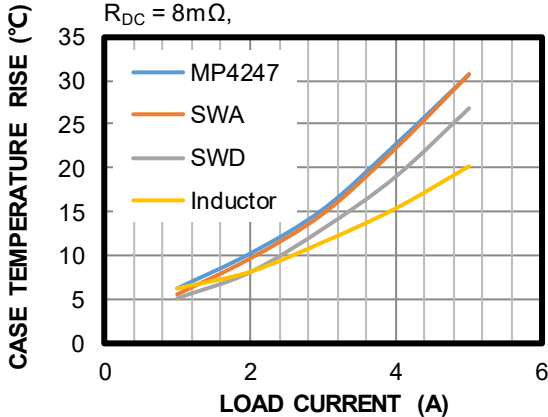

Case Temperature Rise

V_{IN} = 19V, V_{OUT} = 20V, f_{sw} = 420kHz, based on 6cmx6cm board. L = 4.7μH, R_{DC} = 8mΩ

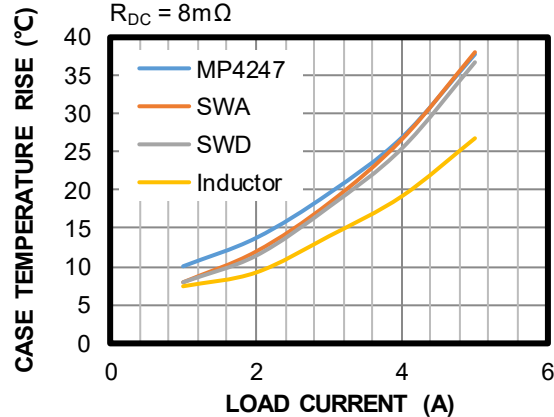

EVB TEST RESULTS

Performance waveforms are tested on the evaluation board. $V_{IN} = 12V$, $V_{OUT} = 5V$, $L = 4.7\mu H$, $f_{SW} = 420kHz$, $T_A = 25^\circ C$, unless otherwise noted.

I²C Operation On
Load = 0A

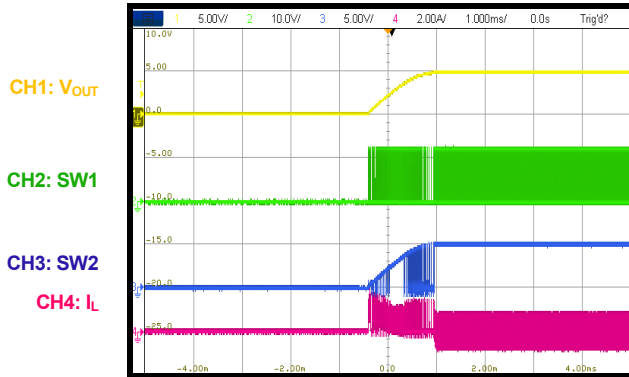

I²C Operation On
Load = 5A

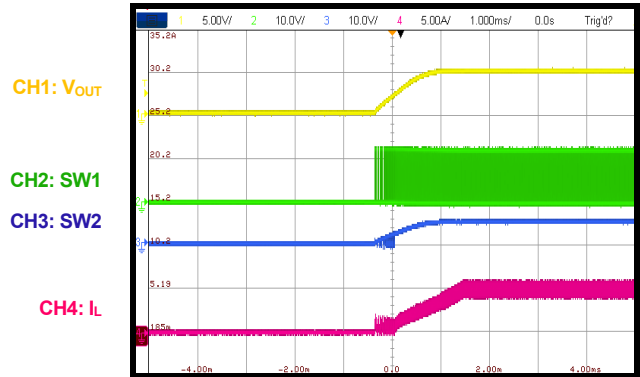

I²C Operation Off
Load = 0A

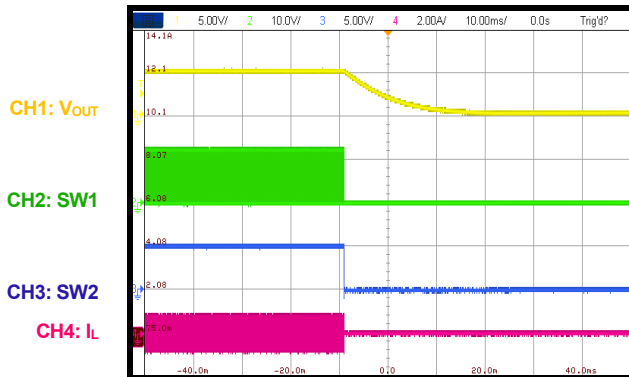

I²C Operation Off
Load = 5A

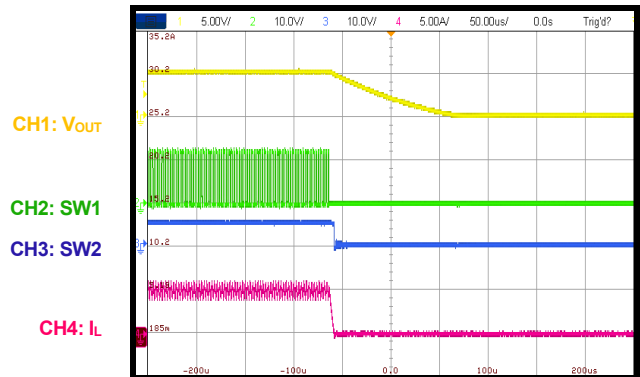

EN Pin Enabled
Load = 0A

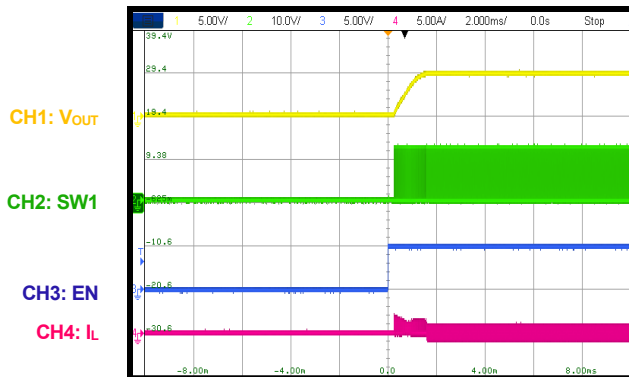

EN Pin Enabled
Load = 5A

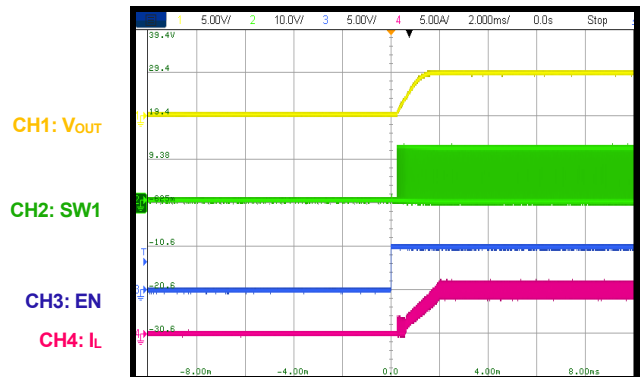

EVB TEST RESULTS (continued)

Performance waveforms are tested on the evaluation board. $V_{IN} = 12V$, $V_{OUT} = 5V$, $L = 4.7\mu H$, $f_{SW} = 420kHz$, $T_A = 25^{\circ}C$, unless otherwise noted.

EN Pin Disabled
Load = 0A

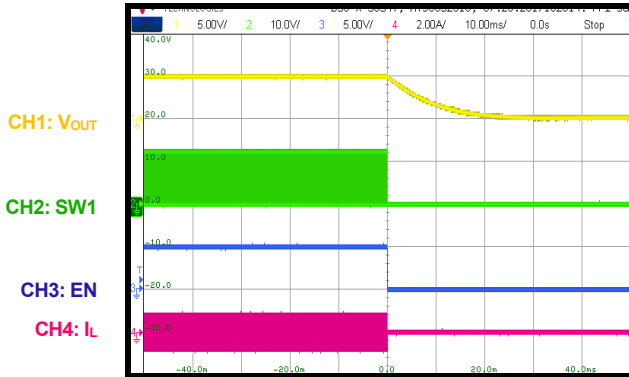

EN Pin Disabled
Load = 5A

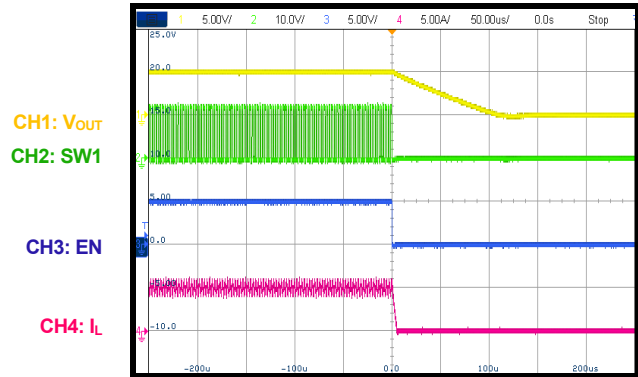

Input Start-Up
Load = 0A

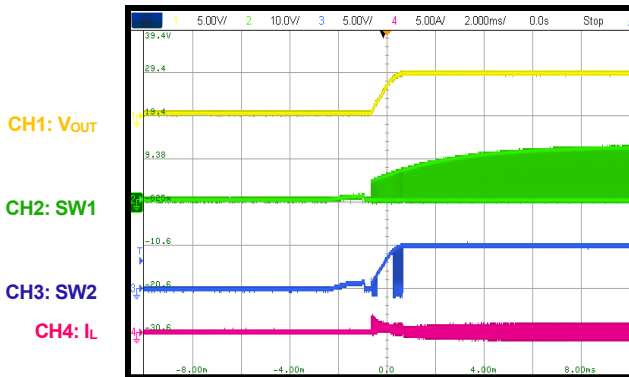

Input Start-Up
Load = 5A

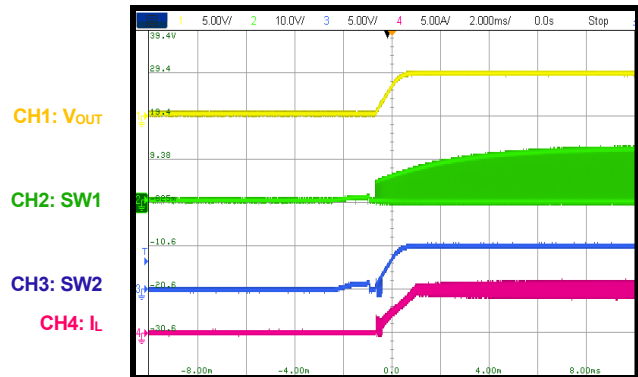

Input Shutdown
Load = 10mA

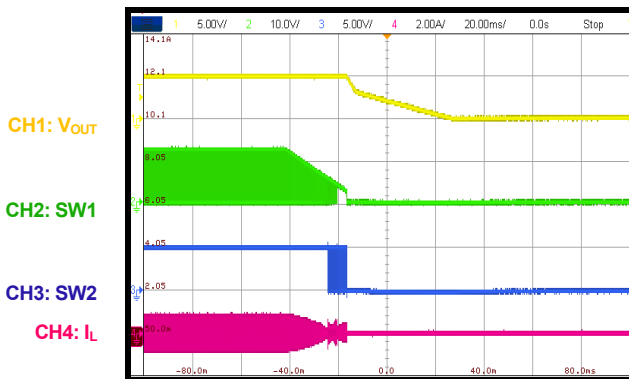

Input Shutdown
Load = 5A

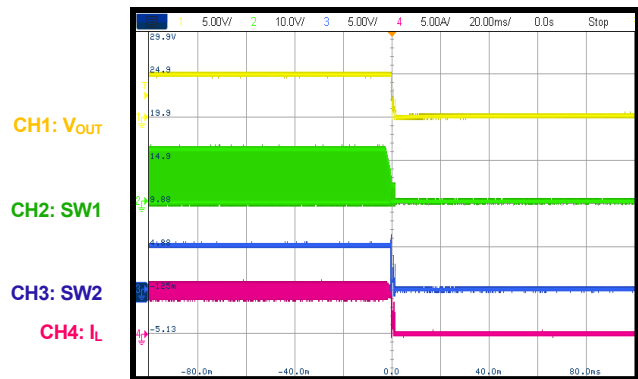

EVB TEST RESULTS (continued)

Performance waveforms are tested on the evaluation board. $V_{IN} = 12V$, $V_{OUT} = 5V$, $L = 4.7\mu H$, $f_{SW} = 420kHz$, $T_A = 25^\circ C$, unless otherwise noted.

Load Transient

$V_{IN} = 12V$, $V_{OUT} = 5V$, $I_{OUT} = 0A$ to $2.5A$, $150mA/\mu s$

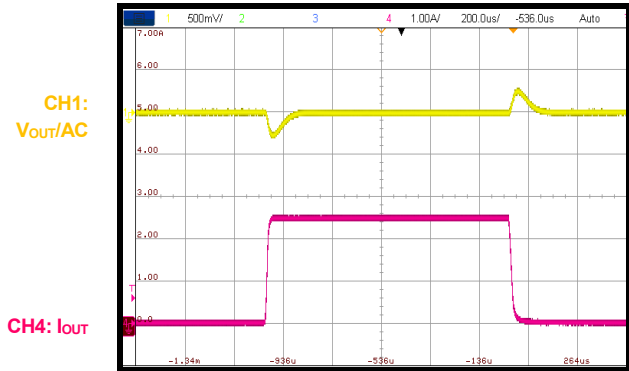

Load Transient

$V_{IN} = 12V$, $V_{OUT} = 5V$, $I_{OUT} = 2.5A$ to $5A$, $150mA/\mu s$

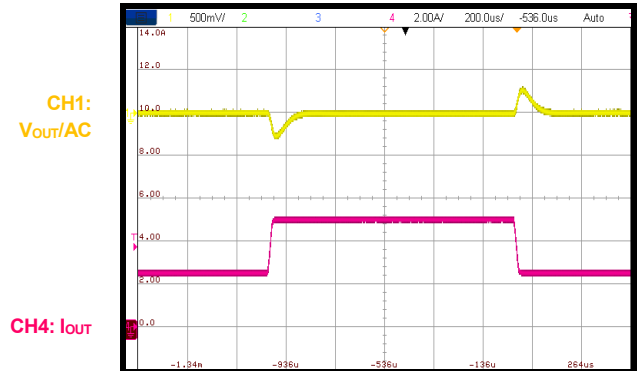

Load Transient

$V_{IN} = 12V$, $V_{OUT} = 20V$, $I_{OUT} = 0A$ to $2.5A$, $150mA/\mu s$

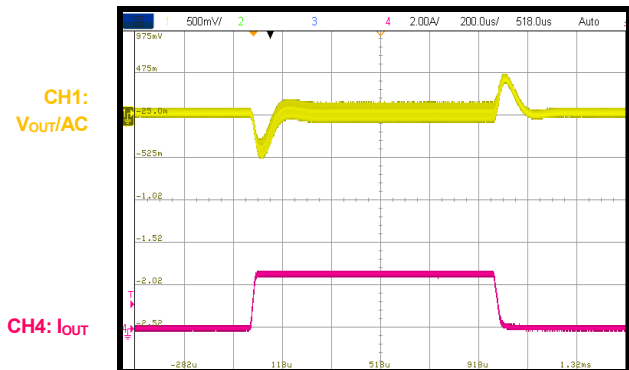

Load Transient

$V_{IN} = 12V$, $V_{OUT} = 20V$, $I_{OUT} = 2.5A$ to $5A$, $150mA/\mu s$

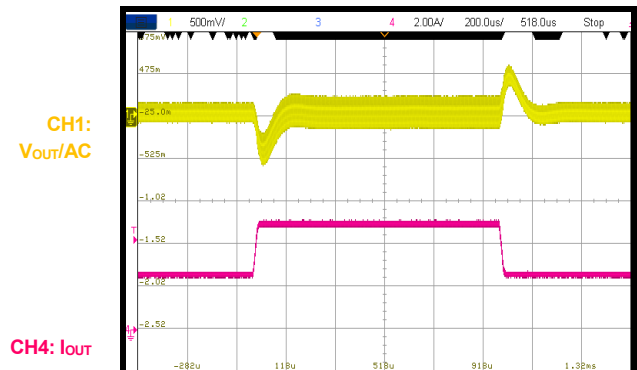

Input Voltage Transient

$V_{IN} = 14V$ to $35V$, $V_{OUT} = 5V$, load = $0A$

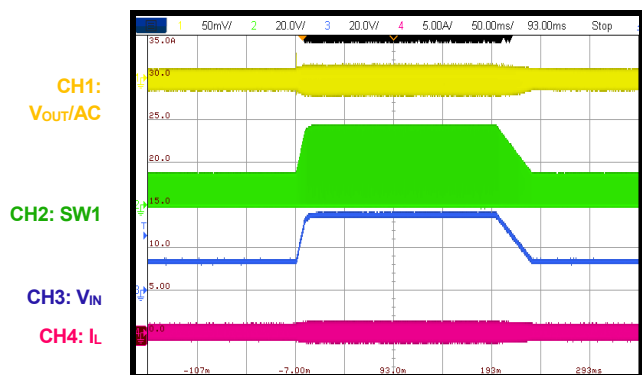

Input Voltage Transient

$V_{IN} = 14V$ to $35V$, $V_{OUT} = 5V$, load = $5A$

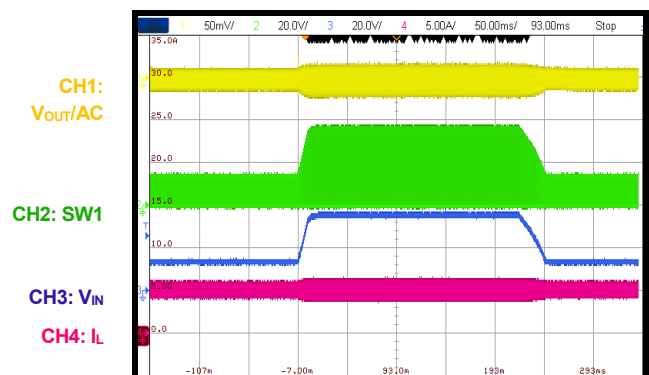

EVB TEST RESULTS (continued)

Performance waveforms are tested on the evaluation board. $V_{IN} = 12V$, $V_{OUT} = 5V$, $L = 4.7\mu H$, $f_{SW} = 420kHz$, $T_A = 25^\circ C$, unless otherwise noted.

Input Voltage Transient
 $V_{IN} = 14V$ to $35V$, $V_{OUT} = 20V$, load = $0A$

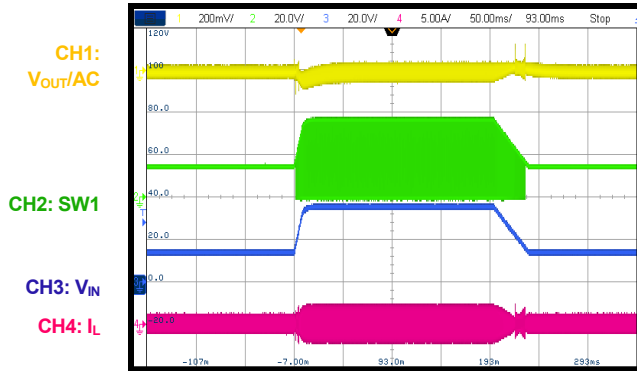

Input Voltage Transient
 $V_{IN} = 14V$ to $35V$, $V_{OUT} = 20V$, load = $3A$

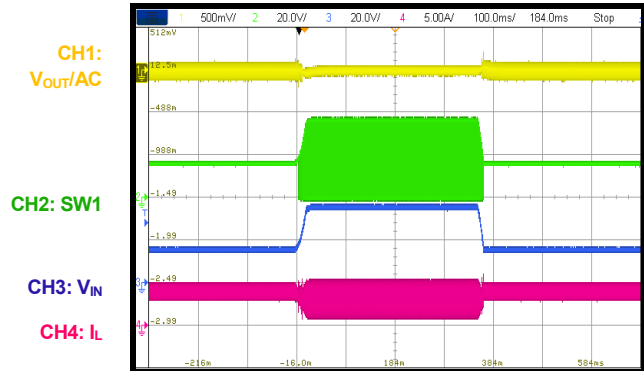

Output Voltage Transition
 $V_{OUT} = 5V$ to $20V$, $I_{OUT} = 0A$

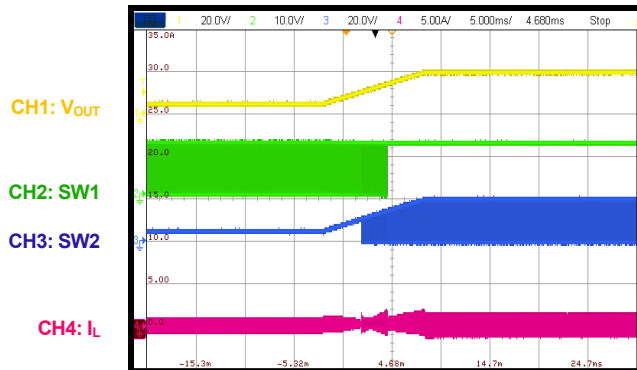

Output Voltage Transition
 $V_{OUT} = 20V$ to $5V$, $I_{OUT} = 0A$

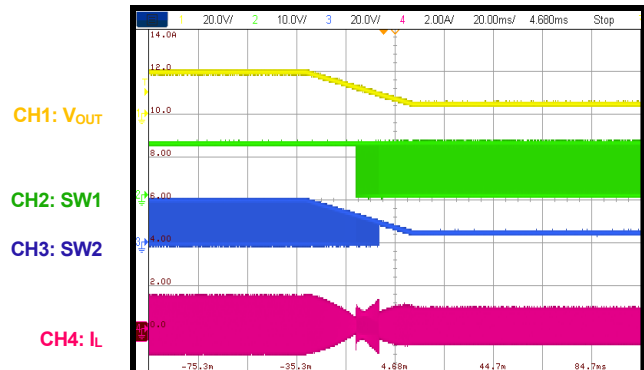

Output Voltage Transition
 $V_{OUT} = 5V$ to $20V$, $I_{OUT} = 5A$

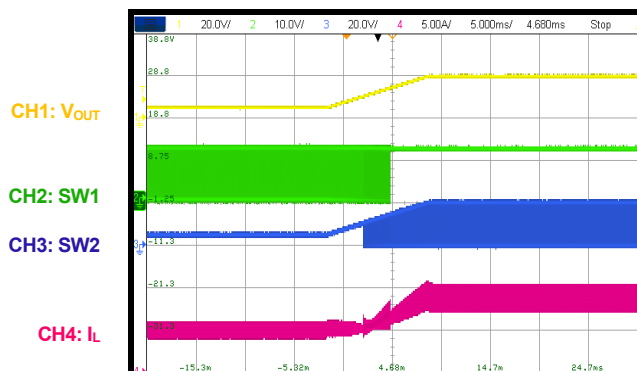

Output Voltage Transition
 $V_{OUT} = 20V$ to $5V$, $I_{OUT} = 5A$

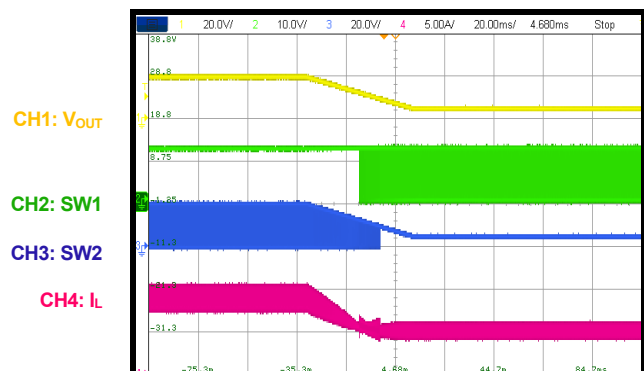

EVB TEST RESULTS (continued)

Performance waveforms are tested on the evaluation board. $V_{IN} = 12V$, $V_{OUT} = 5V$, $L = 4.7\mu H$, $f_{SW} = 420kHz$, $T_A = 25^\circ C$, unless otherwise noted.

CC Entry

CV load = 4V, CC limit = 5.4A

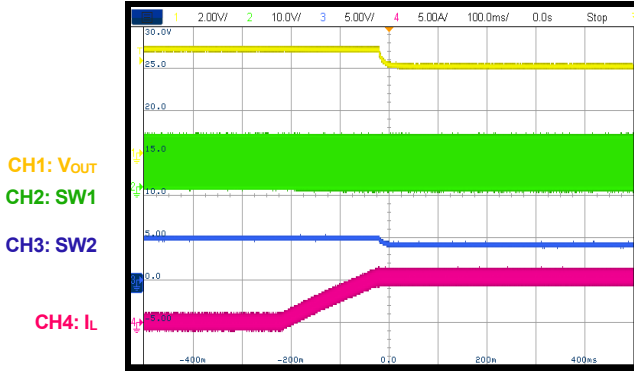

CC Recovery

CV load = 4V, CC limit = 5.4A

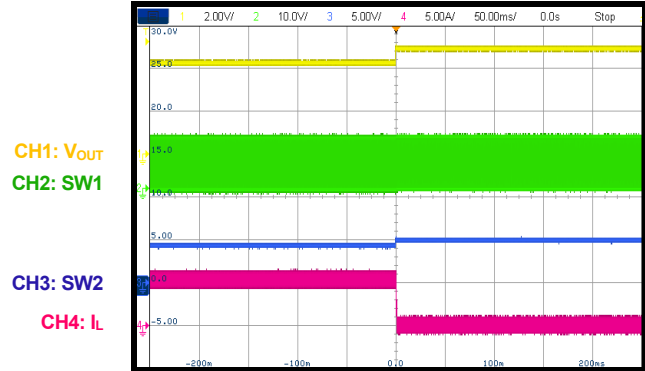

Short Circuit Protection Entry

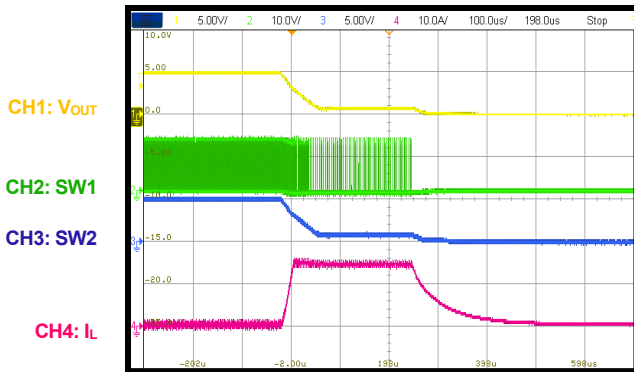

Short Circuit Protection Recovery

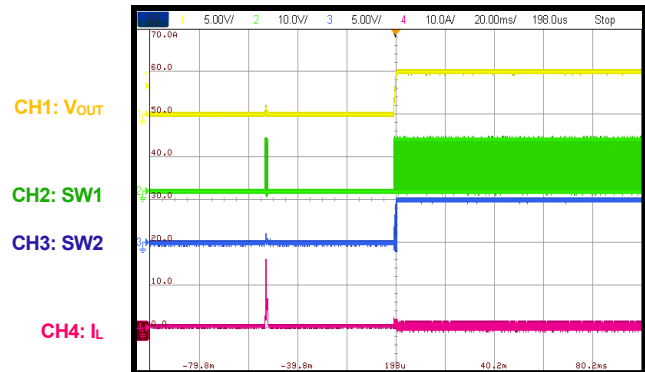

SCP Steady State

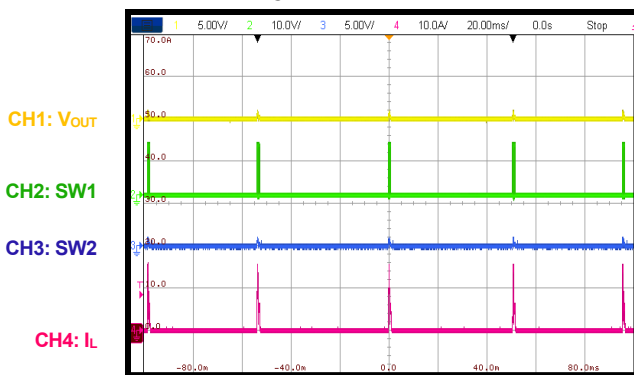

PCB LAYOUT

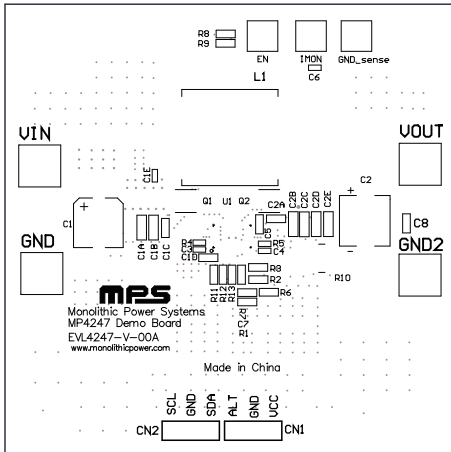

Figure 2: Top Silk Layer

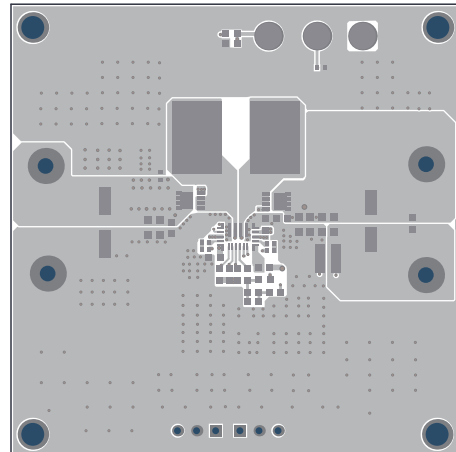

Figure 3: Top Layer

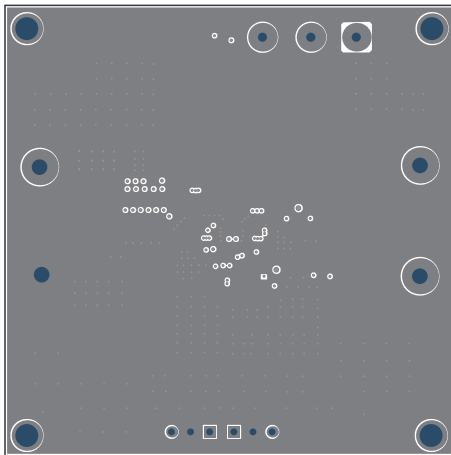

Figure 4: Mid Layer 1

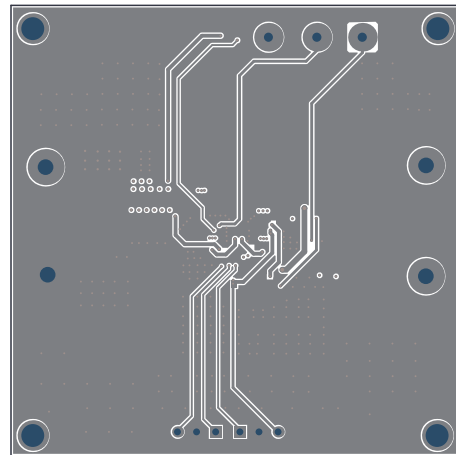

Figure 5: Mid Layer 2

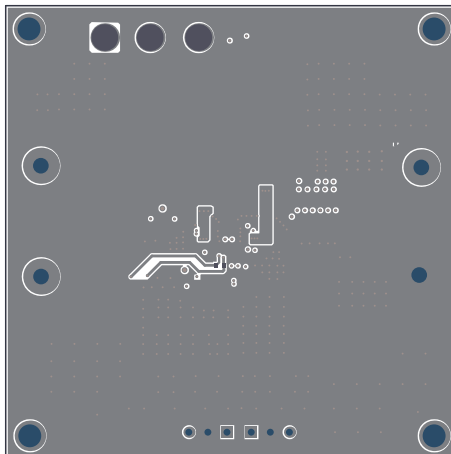

Figure 6: Bottom Layer

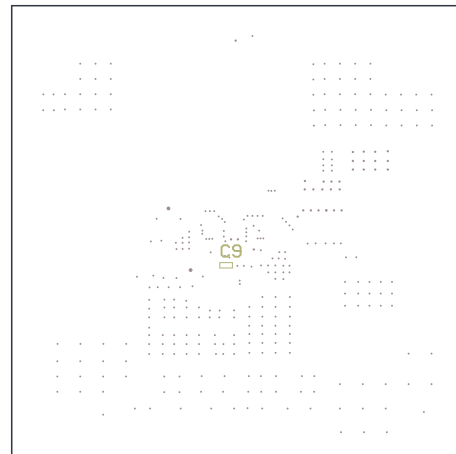

Figure 7: Bottom Silk Layer



REVISION HISTORY

Revision #	Revision Date	Description	Pages Updated
1.0	4/2/2021	Initial Release	-

Notice: The information in this document is subject to change without notice. Please contact MPS for current specifications. Users should warrant and guarantee that third-party Intellectual Property rights are not infringed upon when integrating MPS products into any application. MPS will not assume any legal responsibility for any said applications.