



钜地半导体
Tudi Semiconductor

Product Specification

TUDI-MAX3089

Fail-Safe, High-Speed (12Mbps),
Slew-Rate-Limited RS-485/RS-422 Transceivers

网址 www.sztdbdt.com 🔍

用芯智造 · 卓越品质

**semiconductor device
manufacturer**

- Design
- research and development
- production
- and sales



Features

- Robust performance protection
- $\pm 15\text{kV}$ human model ESD on I/O pins
- True fail-safe receiver maintains EIA485 compatibility
- Enhanced data rates for data transmission
- DE and RE hot-pluggable input structure
- Flexible design characteristics
- 256 transceivers allowed on the bus
- Industry standard SO and DIP packages available
- Low current mode in shutdown for power conservation

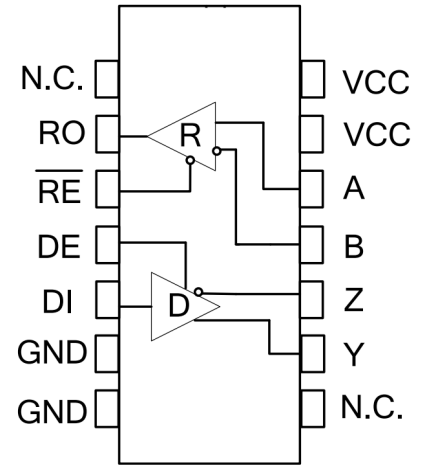

Figure 1 Pin diagram

Description

The MAX3089 high-speed transceiver is designed for RS-485/RS-422 communication and contains a driver and a receiver. These devices guarantee a receiver output of logic high when the receiver input is open or shorted. This means that if all the drivers on the terminated bus are disabled (impedance), the receiver output will be logic high. The MAX3089 can operate at a data rate of 12Mbps. These transceivers typically consume supply current when unloaded or when the driver is disabled. The devices all have a receiver input impedance of 1/8 unit load, allowing a maximum of 256 transceivers on a bus. The MAX3089 is designed for full-duplex communication.

Applications

- RS-422/RS-485 Communications
- Level Translators
- Transceivers for EMI-Sensitive Applications
- Industrial-Control Local Area Networks



Pin description

Pin number	Pin name	Pin function
1	NC	No internal connection, no need to connect;
2	RO	Receiver output. When /RE is low, if $A-B \geq -10\text{mV}$, RO output is high; if $AB \leq -200\text{mV}$, RO output is low.
3	/RE	Receiver output enable control. When /RE is low, the receiver output is enabled and RO is valid; when /RE is high, the receiver is disabled and RO is high impedance; /RE is high and DE is low, the device enters low-power off mode.
4	DE	Driver output enable control. The driver output is active when DE is high, and the output is high-impedance when DE is low; / is high and DE is low, the device enters low-power shutdown mode.
5	DI	DI driver input. A low on DI with DE high causes the driver's A output to be low and B output to be high; a high DI will cause the A output to be high and the B output to be low.
6	GND	grounding
7	GND	grounding
8	NC	No internal connection, no need to connect;
9	Y	Drivers in-phase output
10	Z	Inverting output of the driver
11	B	Inverting input of the receiver
12	A	Receiver in-phase input terminal
13	VCC	This pin can be connected to the power supply ($3\text{V} \leq \text{VCC} \leq 5.5\text{V}$) or can be left unconnected
14	VCC	Power supply: $3\text{V} \leq \text{VCC} \leq 5.5\text{V}$

Extreme parameter

Parameter	Symbol	Unit	size
Continuous power consumption	SOP14	mW	600
	DIP14	mW	700
Power supply voltage	VCC	V	+7
working temperature range		°C	-40~125
Storage temperature range		°C	-60~150
Welding temperature range		°C	300
Control port voltage	DI	V	-0.3~VCC+0.3
Bus side input voltage	A, B	V	-8~13
Receiver output voltage	RO	V	-0.3~VCC+0.3

The maximum limit parameters are values beyond which the device can be damaged in an irreversible manner. Operation of the device under these conditions is not intended to be normal and may affect the reliability of the device if operated continuously at the maximum rated limit. All voltages are referenced to ground.



Parameter	Symbol	Test condition	Minimum	Typical case	Maximum	Unit
Supply current						
Supply current	Icc1	/RE=0V,DE=0V		220	400	uA
	Icc2	/RE=VCC,DE=		240	400	uA
Turn off the current	ISHDN	RE=VCC,DE=0V		0.5	10	uA
ESD protect						
A、B、Y、Z		Human body model(HBM)		±15		KV
Other ports		Human body model(HBM)		±6		KV
The DC electrical characteristics of the receiver						
Input current (A,B)	IN2	VCC=0 or 3.3 V VIN=12 V			125	uA
		VCC=0 or 3.3 V VIN=-7V	-100			uA
Forward input threshold voltage	VIT+	-7V≤VCM≤12 V			-10	mV
Reverse input threshold voltage	VIT-	-7V≤VCM≤12 V	-200			mV
Input the hysteresis voltage	Vhys	-7V≤VCM≤12 V	10	30		mV
High level output voltage	VoH	IoUT=-4mA,VID =+200 mV	VCC-1.5			V
Low-level output voltage	VoL	IoUT=+4mA,VID=-200 mV			0.4	V
Three-state input leakage current	IozR	0.4V<Vo<2.4V			±1	uA
Receiver input resistance	RN	-7V≤VCM≤12 V	96			kΩ
Receiver short-circuit current	IosR	0V≤Vo≤VCC	±7		±95	mA

(If not otherwise, VCC=3V~5.5V, Temp = TMIN ~ TMAX, typical value at Temp = 25) NOTE 1: VO D and? VOC is the change in VOD and VOC amplitude caused when the DI state of the input signal changes, respectively.



Parameter	Symbol	Test condition	Minimum	Typical case	Maximum	Unit
The DC electrical characteristics of the drive device						
Drive differential output(no load)	VoD?		3		5.5	V
Drive differential output	VoD2	Graph 2,RL=27Ω	1.5		VCC	V
		Graph 2,RL=50Ω	2		VCC	
Changes in the output voltage amplitude (NOTE1)	ΔVoD	Graph 2,RL=27Ω			0.2	V
Output common mode voltage	Voc	Graph 2,RL=27Ω			3	V
Change in common mode output voltage amplitude(NOTE 1)	ΔVoc	Graph 2,RL=27Ω			0.2	V
High-level input	VH	DI	2.0			V
Low level input	Vπ	DI			0.8	V
Logical input current	IN?	DI	-2		2	uA
Output short circuit current, short circuit to high	IosD?	Short-circuit to OV~12V	35		250	mA
Output short circuit current, short circuit to low	IosD2	Short-circuit to -7V~OV	-250		-35	mA
Drive switch characteristics						
Drive input to output propagation delay(low to high)	tDPLH	RDIFF=54Ω, CLi=CL?=100 pF (see Figure 3 and Figure 4)		15	35	ns
Drive input to output propagation delay(high to low)	tDPHL			15	35	ns
tDPLH-tDPHL	tsKEW1			7	10	ns
Up along time / down along time	tDR,tDF			10	25	ns
Amission to output high	tpZH	RL =1109,(see Figure 5,6)		20	90	ns
The enabling to output is low	tpZL			20	90	ns
Input low to no energy	tPLz	RL =110 Ω, (see Figure		20	80	ns
Input high to no energy	tPHZ			20	80	ns
Under off conditions,the output is high	tDSH	RL =1109,(see Figure 5,6)		500	900	ns
Under off conditions,enabling output low	tDSL	RL=1109,(see Figure 5,6)		500	900	ns



Parameter	Symbol	Test condition	Minimum	Typical case	Maximum	Unit
Receiver Switch characteristics						
Ento output high time	tRPZH	C=15 pF is shown in Figure		20	50	ns
From low output to energy-forbidden time	tpRLZ	For CL =15 pF, see Figure 7		20	45	ns
From high output to energy forbidden time	tPRHZ	For CL =15 pF, see Figure 7		20	45	ns
Enables high output time in the off state	tRPSH	For CL =15 pF, see Figure 7		200	1400	ns
Ento output low time in off state	tRPSTL	For CL =15 pF, see Figure 7		200	1400	ns
Time in the off state	tsHDN	NOTE2	80		300	ns
Acceptor	tRPLH	See Figure 7 and Figure 8	20	60	90	ns
Input to output propagation latency is from low to high						
The receiver input to output propagation latency is obtained from high to low	tRPHL	VID 2.0V;rise and fall along time VID 15ns	20	60	90	ns
tRPLH-tRPHL	tsKEW2			7	10	ns
Ability to reach the output for a low time	tRPZL	For CL =15 pF, see Figure 7		20	50	ns

Function table

Receiving function table			
control		input	output
/RE	DE	A-B	RO
0	X	$\geq -10\text{mV}$	H
0	X	$\leq -200\text{mV}$	L
0	X	Open/short circuit	H
1	X	X	Z
X: any level; Z: high impedance.			

Send function table				
control		input	output	
/RE	DE	DI	Y	Z
X	1	1	H	L
X	1	0	L	H
0	0	X	Z	Z
1	0	X	Z(shutdown)	
X: any level; Z: high impedance.				

Test circuit

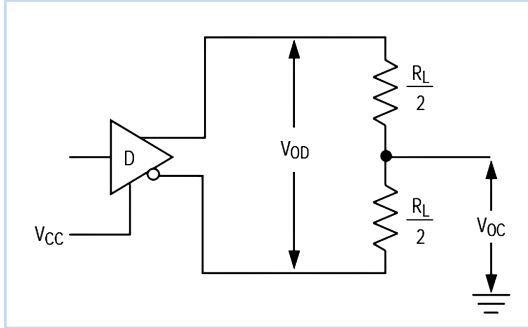

Figure 2: DC test load for the drive

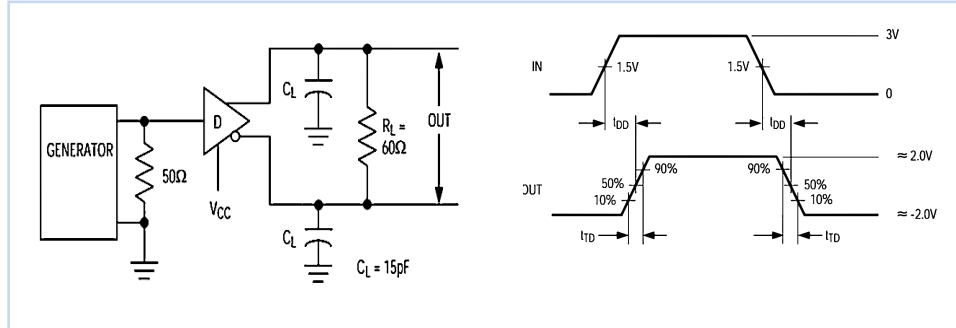

Figure 3 Drive-line Differential Delay and Transit Time

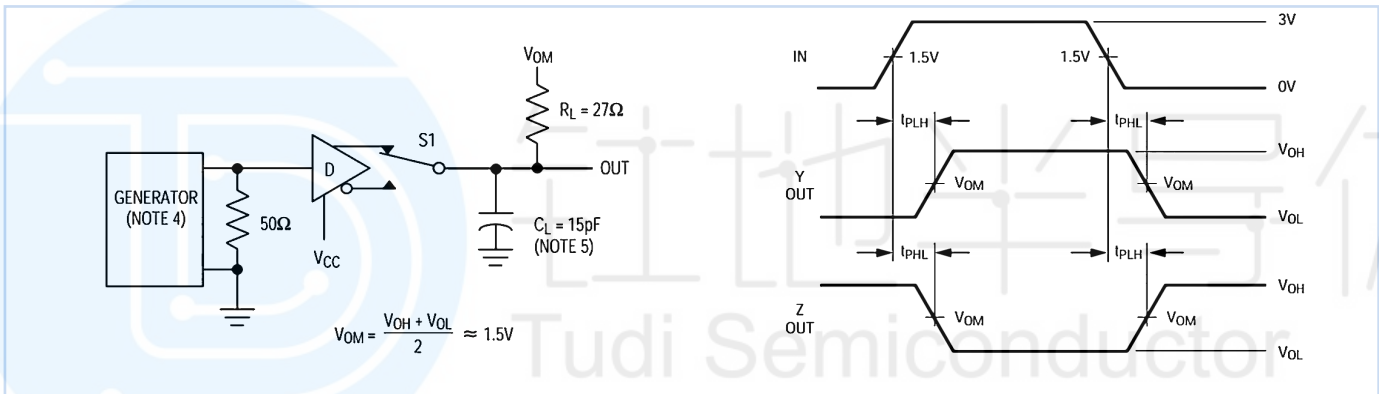

Figure 4 Drive propagation delay

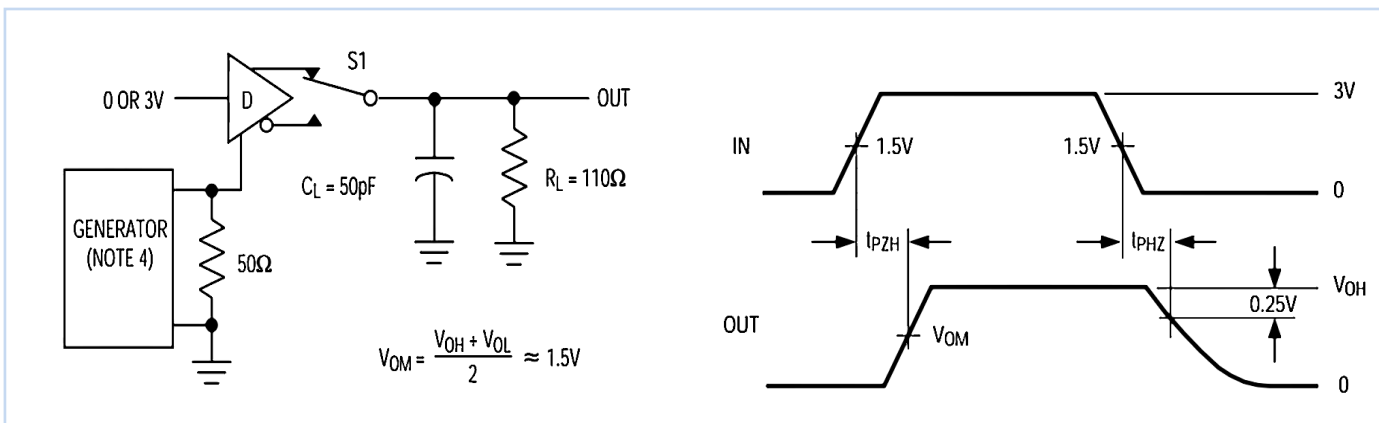

Figure 5 Drive enable and disable time

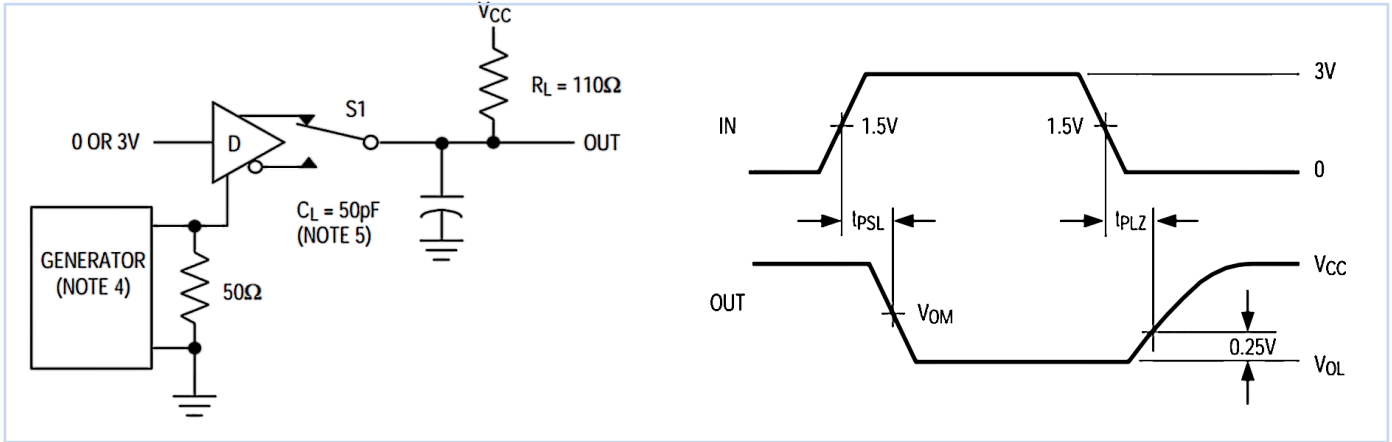

Figure 6 Drive enable and disable time

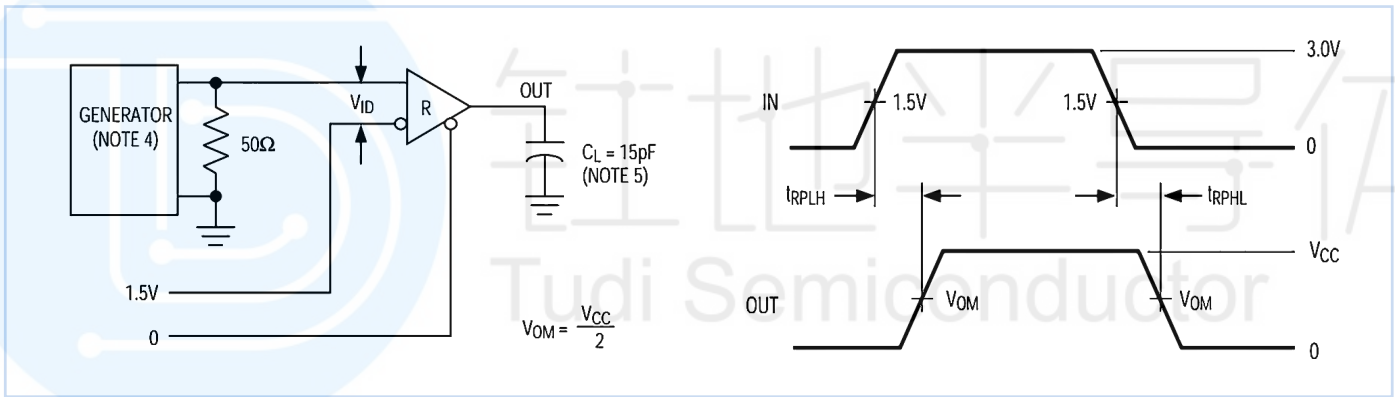
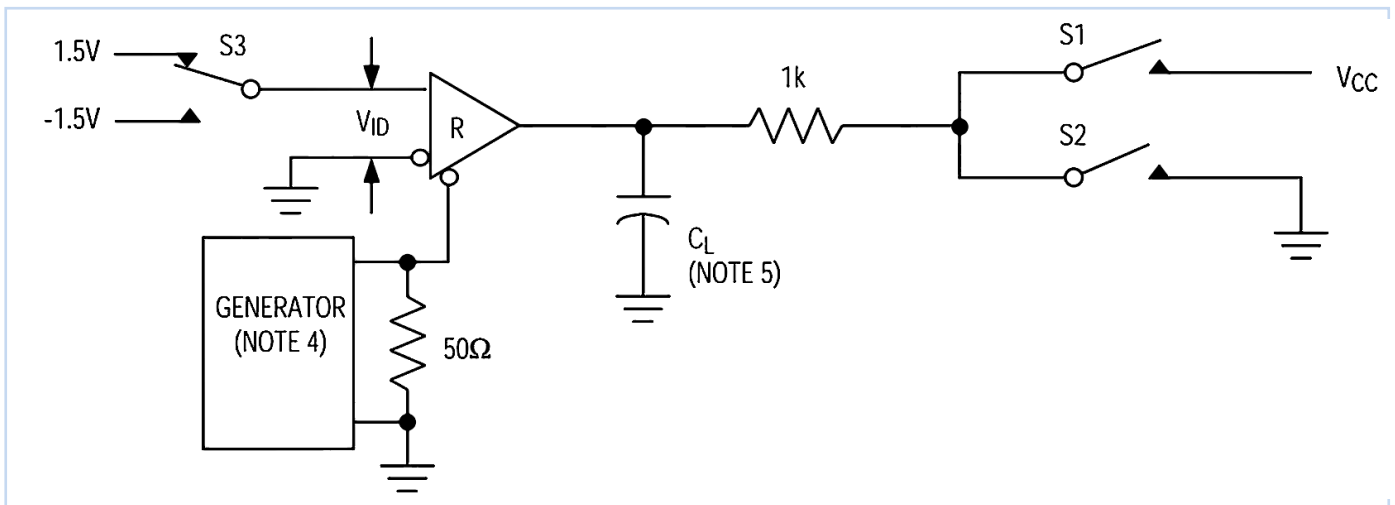

Figure 7: Receiver Propagation Delay Test Circuit



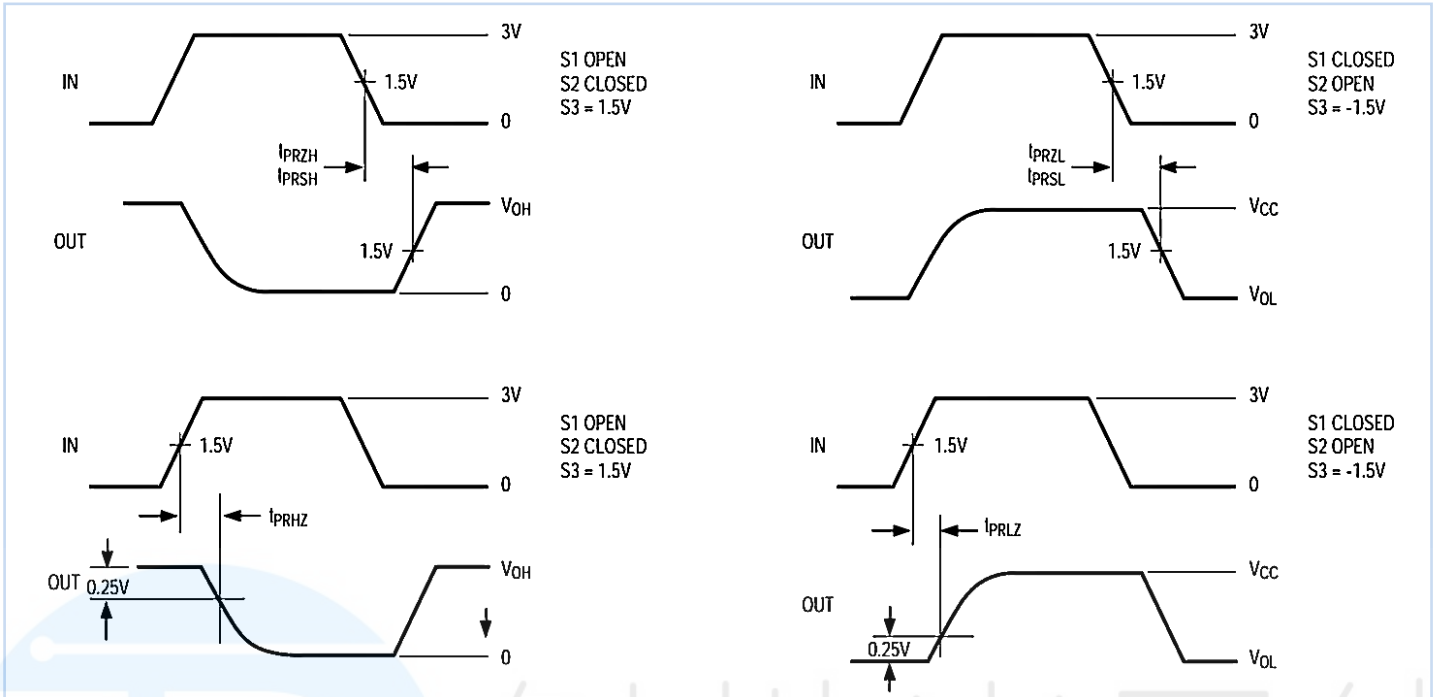

Figure 8 Receive enable and disable time

Order information

Order Number	Package	Package Quantity	Marking On The park	Temperature
MAX3089CSD-TUDI	SOP14	Tape,Reel,2500	MAX3089CSD	0°C to 70°C
MAX3089CPD-TUDI	DIP14	Tube,25,A box of 1000	MAX3089CPD	
MAX3089ESD-TUDI	SOP14	Tape,Reel,2500	MAX3089ESD	- 40°C to 85°C
MAX3089EPD-TUDI	DIP14	Tube,25,A box of 1000	MAX3089EPD	



Package SOP14

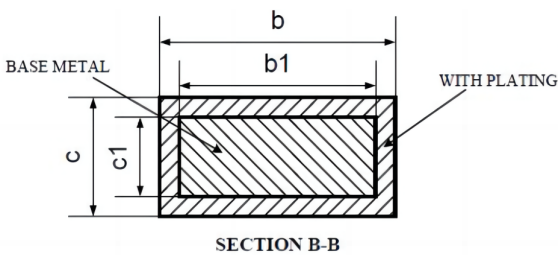
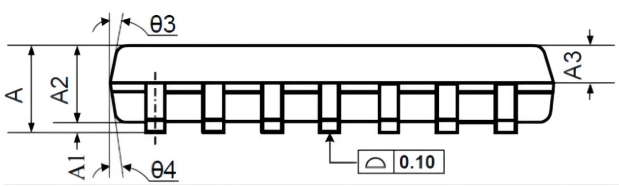
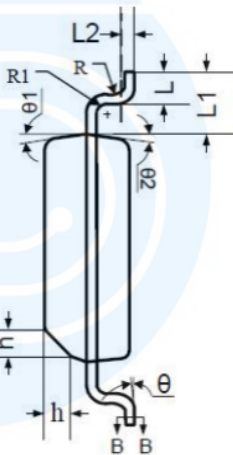
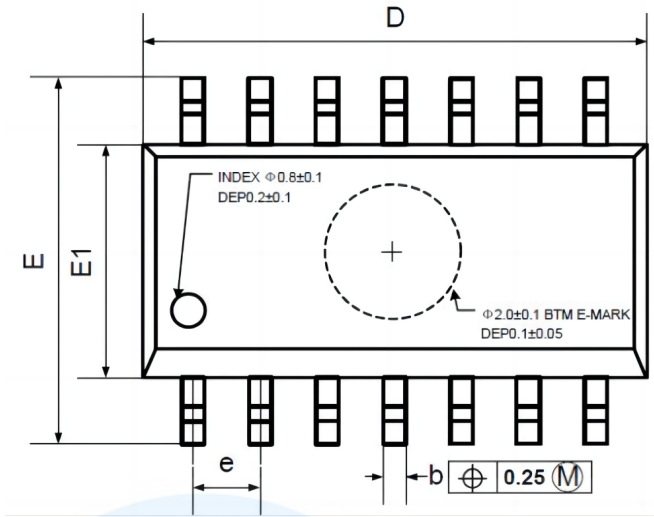

Symbol	Dimensions In Millimeters		
	MIN	NOM	MAX
A	1.35	1.60	1.75
A1	0.10	0.15	0.25
A2	1.25	1.45	1.65
A3	0.55	0.65	0.75
b	0.36		0.49
b1	0.35	0.40	0.45
C	0.16		0.25
c1	0.15	0.20	0.25
D	8.53	8.63	8.73
E	5.80	6.00	6.20
E1	3.80	3.90	4.00
e	1.27 BSC		
L	0.45	0.60	0.80
L1	1.04 REF		
L2	0.25 BSC		
R	0.07		
R1	0.07		
h	0.30	0.40	0.50
θ	0°		8°
θ1	6°	8°	10°
θ2	6°	8°	10°
θ3	5°	7°	9°
θ4	5°	7°	9°



Package DIP14

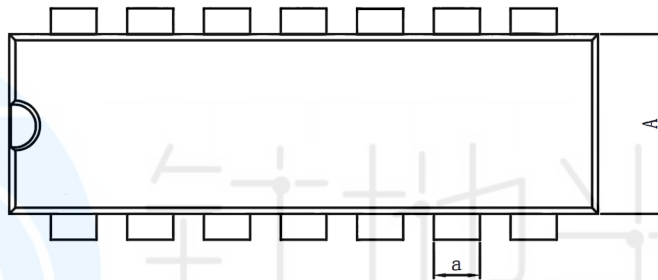
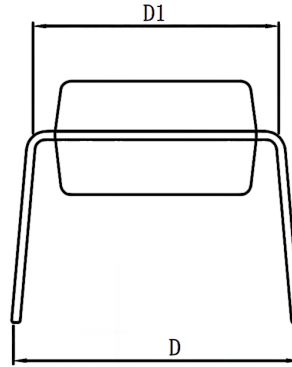
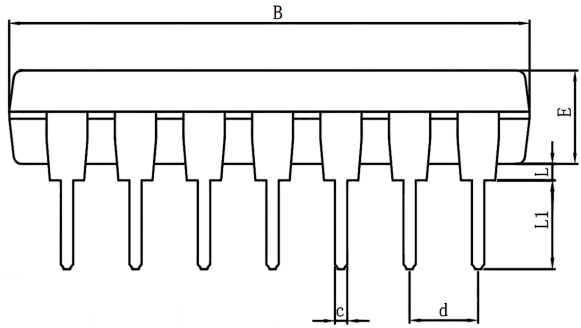

DIM.	MIN	TYP	MAX	DIM.	MIN	TYP	MAX
A	6.100	6.300	6.680	a	1.504	1.524	1.544
B	18.940	19.200	19.560	C	0.437	0.457	0.477
D	8.200	8.700	9.200	d	2.530	2.540	2.550
D1	7.42	7.62	7.82	L	0.500	—	0.800
E	3.100	3.300	3.550	L1	3.000	3.200	3.600



Important statement:

- TUDI Semiconductor reserves the right to modify the product manual without prior notice! Before placing an order, customers need to confirm whether the obtained information is the latest version and verify the completeness of the relevant information.
- Any semi-guide product is subject to failure or malfunction under specified conditions. It is the buyer's responsibility to comply with safety standards when using TUDI Semiconductor products for system design and whole machine manufacturing. And take the appropriate safety measures to avoid the potential in the risk of loss of personal injury or loss of property situation!
- TUDI Semiconductor products have not been licensed for life support, military, and aerospace applications, and therefore TUDI Semiconductor is not responsible for any consequences arising from the use of this product in these areas.
- If any or all TUDI Semiconductor products (including technical data, services) described or contained in this document are subject to any applicable local export control laws and regulations, they may not be exported without an export license from the relevant authorities in accordance with such laws.
- The specifications of any and all TUDI Semiconductor products described or contained in this document specify the performance, characteristics, and functionality of said products in their standalone state, but do not guarantee the performance, characteristics, and functionality of said products installed in Customer's products or equipment. In order to verify symptoms and conditions that cannot be evaluated in a standalone device, the Customer should ultimately evaluate and test the device installed in the Customer's product device.
- TUDI Semiconductor documentation is only allowed to be copied without any alteration of the content and with the relevant authorization. TUDI Semiconductor assumes no responsibility or liability for altered documents.
- TUDI Semiconductor is committed to becoming the preferred semiconductor brand for customers, and TUDI Semiconductor will strive to provide customers with better performance and better quality products.