

**BT137-600E-D**
**MAIN FEATURES      4Q TRIAC**

Symbol	Value	Unit
$I_{T(RMS)}$	8	A
$V_{DRM}/V_{RRM}$	600	V
$I_{GT1/2/3/4}$	10/10/10/25	mA

**DESCRIPTION:**

The BT137-600E-D triac is suitable for general purpose AC switching. It can be used as an ON/OFF function in applications such as heating regulation, induction motor starting circuits, for phase control operation in light dimmers, motor speed controllers.

Package TO-252 is RoHS compliant.

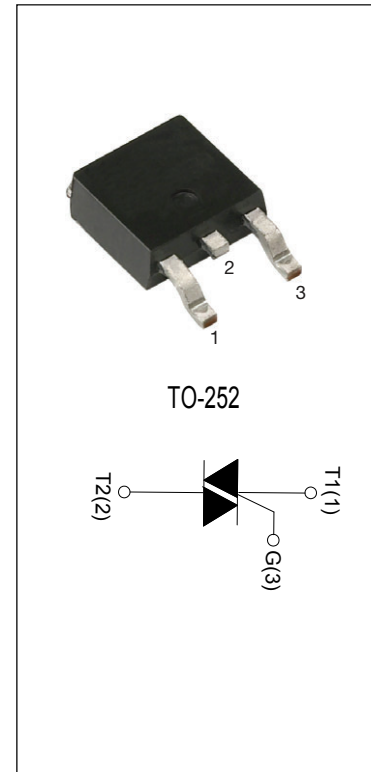
**ABSOLUTE MAXIMUM RATINGS**

Parameter	Symbol	Value	Unit
Storage junction temperature range	$T_{stg}$	-40-150	°C
Operating junction temperature range	$T_j$	-40-125	°C
Repetitive peak off-state voltage ( $T_j=25^\circ\text{C}$ )	$V_{DRM}$	600	V
Repetitive peak reverse voltage ( $T_j=25^\circ\text{C}$ )	$V_{RRM}$	600	V
RMS on-state current ( $T_c \leq 90^\circ\text{C}$ )	$I_{T(RMS)}$	8	A
Non repetitive surge peak on-state current (full cycle , $t_p=10\text{ms}$ , $T_j=25^\circ\text{C}$ )	$I_{TSM}$	80	A
$I^2t$ value for fusing ( $t_p=10\text{ms}$ , $T_j=25^\circ\text{C}$ )	$I^2t$	64	$\text{A}^2\text{s}$
Critical rate of rise of on-state current ( $T_j=125^\circ\text{C}$ )	$di/dt$	50	$\text{A}/\mu\text{s}$
Peak gate current ( $t_p=20\mu\text{s}$ , $T_j=125^\circ\text{C}$ )	$I_{GM}$	4	A
Average gate power dissipation ( $T_j=125^\circ\text{C}$ )	$P_{G(AV)}$	1	W

**ELECTRICAL CHARACTERISTICS** ( $T_j=25^{\circ}\text{C}$  unless otherwise specified)

Symbol	Test Condition	Quadrant	Value		Unit
$I_{GT}$	$V_D=12\text{V } R_L=100\Omega$	I - II - III	MAX.	10	mA
		IV		25	
$V_{GT}$		ALL	MAX.	1	V
$V_{GD}$	$V_D=V_{DRM} T_j=125^{\circ}\text{C}$ $R_L=100\Omega$	ALL	MIN.	0.2	V
$I_L$	$I_G=1.2I_{GT}$	I - III - IV	MAX.	60	mA
		II		100	
$I_H$	$I_T=500\text{mA}$		MAX.	60	mA
$dV/dt$	$V_D=2/3V_{DRM} T_j=125^{\circ}\text{C}$		MIN.	500	V/ $\mu\text{s}$
$(dI/dt)_c$	$T_j=125^{\circ}\text{C}$		MIN.	10	A/ms

**STATIC CHARACTERISTICS**

Symbol	Parameter		Value(MAX.)	Unit
$V_{TM}$	$I_{TM}=12\text{A } t_p=380\mu\text{s}$	$T_j=25^{\circ}\text{C}$	1.60	V
$V_{TO}$	Threshold voltage	$T_j=125^{\circ}\text{C}$	0.86	V
$R_D$	Dynamic resistance	$T_j=125^{\circ}\text{C}$	36.6	m $\Omega$
$I_{DRM}$	$V_D=V_{DRM} V_R=V_{RRM}$	$T_j=25^{\circ}\text{C}$	5	$\mu\text{A}$
$I_{RRM}$		$T_j=125^{\circ}\text{C}$	1	mA

**THERMAL RESISTANCES**

Symbol	Parameter	Value	Unit
$R_{th(j-c)}$	junction to case (AC)	1.25	$^{\circ}\text{C/W}$

**ORDERING INFORMATION**

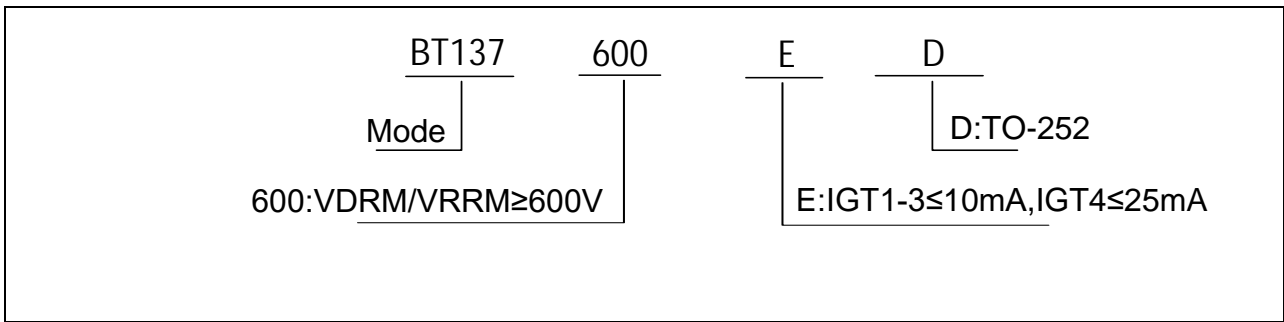

**MARKING**

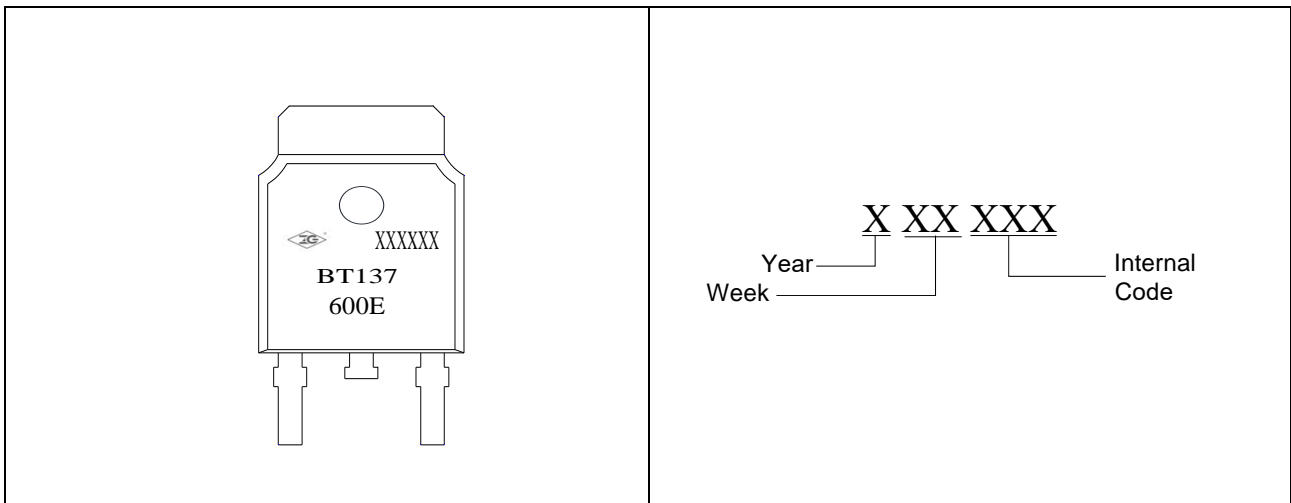

**ORDERING INFORMATION**

Order code	Voltage V <sub>DRM</sub> /V <sub>R<sub>RRM</sub></sub> (V)	IGT(mA)		Package	Base qty. (pcs)	Delivery mode
		I -II-III	IV			
BT137-600E-D	600	10	25	TO-252	2500	Tube

PACKAGE MECHANICAL DATA

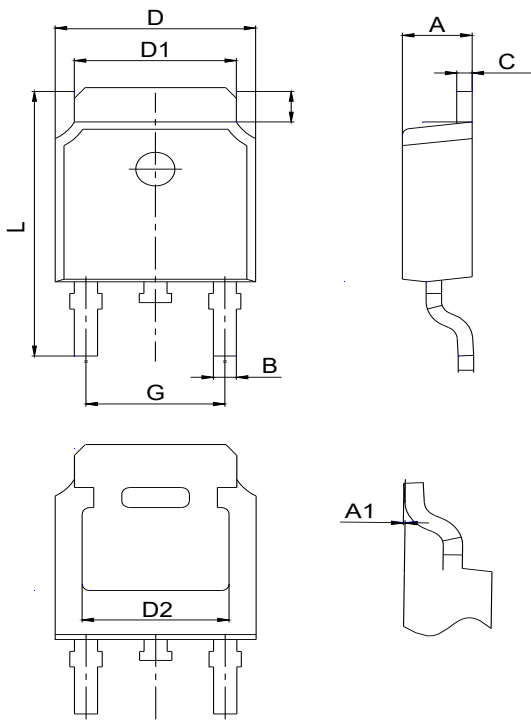

TO-252

Ref.	Dimensions		
	Millimeters		
	Min.	Typ.	Max.
A	2.10	2.30	2.50
A1	/	/	0.13
B	0.47	0.67	0.87
C	0.30	0.50	0.70
D	6.40	6.60	6.80
D1	5.13	5.33	5.53
D2	4.830REF		
G	4.37	4.57	4.77
L	9.80	10.00	10.20

DELIVERY MODE

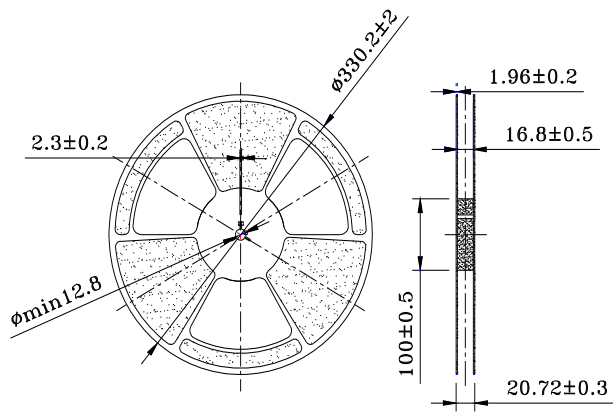
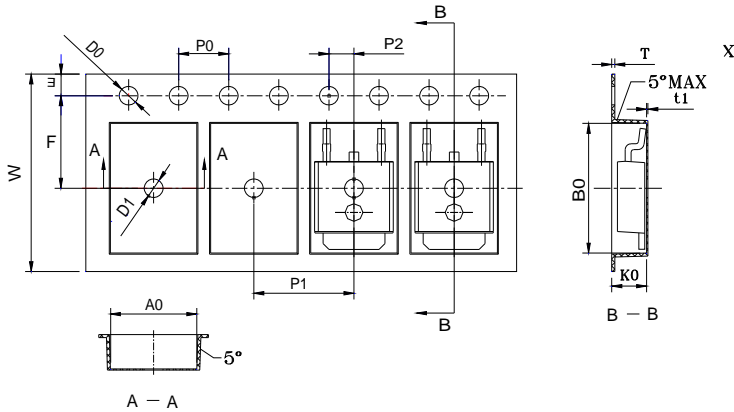

Ref.	Dimensions		
	Millimeters		
	Min.	Typ.	Max.
W	15.90	16.00	16.10
E	1.65	1.75	1.85
F	7.40	7.50	7.60
D0	1.50	1.55	1.60
D1	1.50	/	/
P0	3.90	4.00	4.10
P1	7.90	8.00	8.10
P2	1.90	2.00	2.10
10P0	39.8	40.00	40.20
A0	6.80	6.90	7.00
B0	10.40	10.50	10.60
K0	2.60	2.70	2.80
T	0.25	0.30	0.35
t1	0.10	/	/

PACKAGE	OUTLINE	REEL (PCS)	PER CARTON (PCS)
TO-252	TAPING	2,500	5,000

**FIG.1** Maximum power dissipation versus RMS on-state current

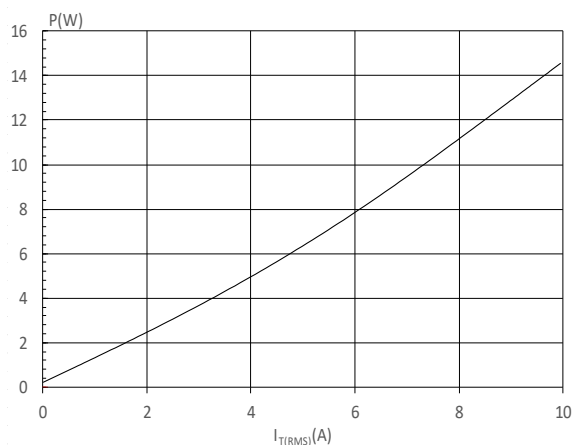

**FIG.2:** RMS on-state current versus case temperature

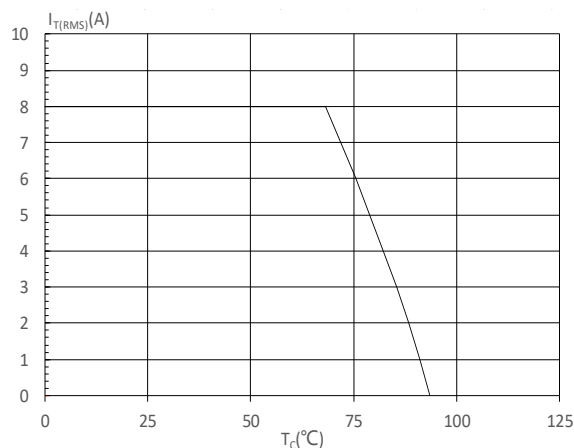

**FIG.3:** Surge peak on-state current versus number of cycles

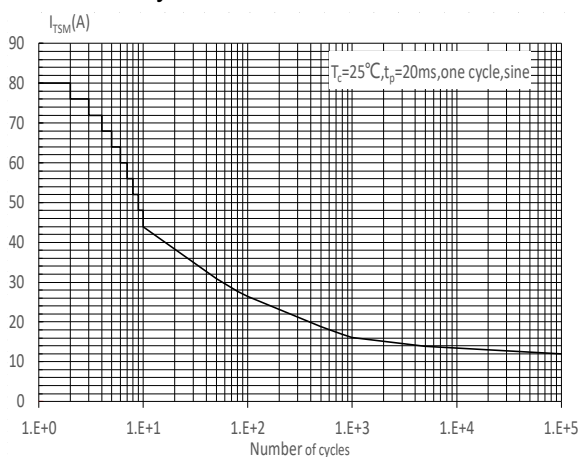

**FIG.4:** On-state characteristics

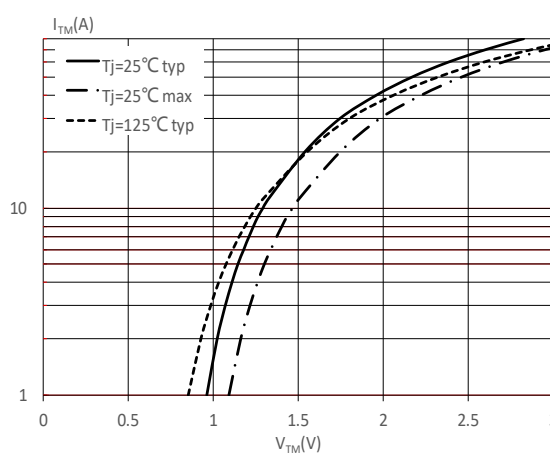

**FIG.5:** Non-repetitive surge peak on-state current for a sinusoidal pulse with width  $t_p < 20\text{ms}$ , and corresponding value of  $I^2t$  ( I - II:  $di/dt < 80\text{A}/\mu\text{s}$ ; III-IV:  $di/dt < 40\text{A}/\mu\text{s}$ )

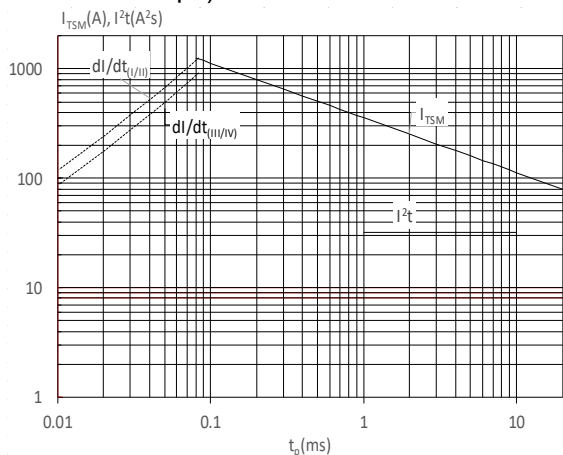

**FIG.6:** Relative variations of gate trigger current, holding current and latching current versus junction temperature

