

for Automotive Electronics

SPECIFICATIONS

Customer	
Product Name	Wire Wound SMD Power Inductor
Sunlord Part Number	AS1A322517100MT
Customer Part Number	

New Released, Revised]

SPEC No. : AS1A01260002

【This SPEC is total 13 pages.】

【ROHS Compliant Parts】

Approved By	Checked By	Issued By
		

Sunlord Electronics Co., Ltd.

Address: Sunlord Industrial Park, Dafuyuan Industrial Zone, Guanlan, Shenzhen, China 518110
 Tel: 0086-755-29832333 Fax: 0086-755-82269029 E-Mail: sunlord@sunlordinc.com

【For Customer approval Only】

Date: _____

Qualification Status: Full Restricted Rejected

Approved By	Verified By	Re-checked By	Checked By

Comments:

【Version change history】

Rev.	Date	Item	Changed Contents	Change Reasons	Drawing	Check	Approval
01	Feb.02,2026	/	/	New release	Pinfan Shen	/	Lei Wu

for Automotive Electronics

〈Content〉

No.	Item	Page
1	Scope	4
2	Product Description and Identification (Part Number)	4
3	Shape and Dimensions	4~5
4	Test and Measurement Procedures	5
5	Structure	6
6	Product Marking	6
7	Reliability Test	7
8	Packaging and Storage	8~10
9	Visual inspection standard of product	11
10	Recommended Soldering Technologies	12
11	Precautions	12
12	Electrical Characteristics	13

for Automotive Electronics

1 Scope

1.1 Scope of parts

This specification applies to the AS1A322517100MT of wire wound SMD power inductor for automotive electronics based on AEC-Q200

1.2 Scope of application

Product numbers recorded in this specification are used in all automotive components.

1.3 Operating and storage temperature

The part temperature (ambient + temp. rise) should not exceed 125°C under worst case operating conditions. Circuit design, component placement, PCB trace size and thickness, airflow and other cooling provisions all affect the part temperature. Part temperature should be verified in the end application.

- 1) Operating and storage temperature range (individual chip without packing): -40°C ~ +125°C (including-self-generated heat).
- 2) Storage temperature range (packaging conditions): -10°C~+40°C and RH 70% (Max.).

2 Product Description and Identification (Part Number)

1) Description:

AS1A322517100MT Wire wound SMD power inductor.

2) Product Identification (Part Number)

A	S	1	A	322517	100	M	T
①	②	③	④	⑤	⑥	⑦	⑧

①	Feature Code
A	For Automotive

②	Apply the code
S	For on-board control systems/safety systems

③	Process platform Code
1	Coated power inductor platform

④	Series code
A	Ferrite core

⑤	External Dimensions(LxWxH) [mm]
322517	3.2 X 2.5 X 1.7

⑥	Nominal Impedance
Example	Example
100	10uH

⑦	Inductance Tolerance
M	±20%

⑧	Packing
T	Tape Carrier Package

3 Shape and Dimensions

Dimensions and recommended PCB pattern for reflow soldering, please see Fig.3-1, Fig. 3-2 and Table3-1.

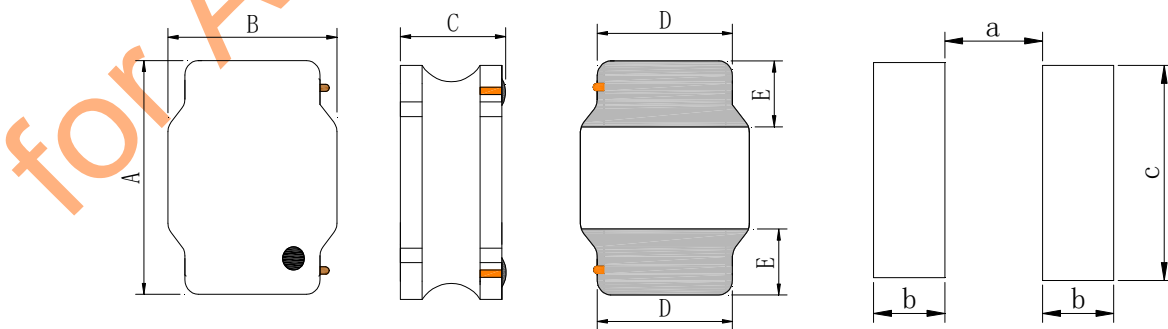

Fig.3-1

[Table 3-1] (Unit: mm)

Part Number	A	B	C	D	E	a	b	c
AS1A322517	3.20±0.2	2.50±0.2	1.70Max	2.00±0.2	0.90±0.2	1.40Typ.	0.95Typ.	1.90Typ

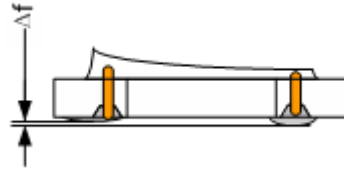

Fig.3-2

Δf: Clearance between terminal and the surface of plate must be 0.1mm max when coil is placed on a flat plate.

4 Test and Measurement Procedures

4.1 Test Conditions

4.1.1 Unless otherwise specified, the standard atmospheric conditions for measurement/test as:

- a. Ambient Temperature: 20±15°C
- b. Relative Humidity: 65±20%
- c. Air Pressure: 86kPa to 106kPa

4.1.2 If any doubt on the results, measurements/tests should be made within the following limits:

- a. Ambient Temperature: 20±2°C
- b. Relative Humidity: 65±5%
- c. Air Pressure: 86kPa to 106kPa

4.2 Visual Examination

Inspection Equipment: Visual.

4.3 Electrical Test

4.3.1 Inductance (L)

- a. Refer to **Appendix A**. Test equipment: WK3260B LCR meter or equivalent.
- b. Test Frequency and Voltage: refers to **Appendix A**.

4.3.2 Direct Current Resistance (DCR)

- a. Refer to **Appendix A**.
- b. Test equipment: HIOKI 3540 or equivalent.

4.3.3 Saturation Current (Isat)

- a. Refer to **Appendix A**.
- b. Test equipment: WK3260B LCR meter or equivalent.

4.3.4 Temperature rise current (Irms)

- a. Refer to **Appendix A**.
- b. Test equipment (see Fig. 4.3.4-1, Fig. 4.3.4-2): Electric Power, Electric current meter, Thermometer.
- c. Measurement method
 1. Set test current to be 0 mA.
 2. Measure initial temperature of choke surface.
 3. Gradually increase current and measure choke temperature for corresponding current.
 4. Definition of Temperature rise current: DC current that causes the temperature rise (ΔT) from ambient temperature.

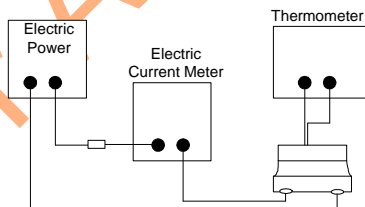

Fig. 4.3.4-1

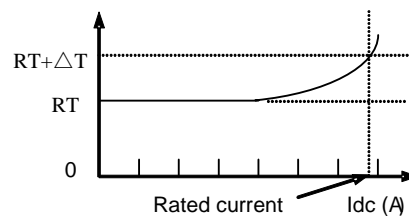

Fig. 4.3.4-2

4.3.5 Self-resonant frequency(SRF)

- a. Refer to **Appendix A**.
- b. Test equipment: Agilent E4991A+16197 or equivalent

5 Structure

The structure of AS1A322517 series of product, please refer to Fig.5-1 and Table 5-1.

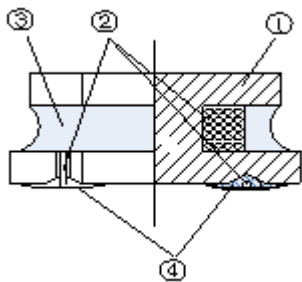

[Table 5-1]

No.	Components	Material
①	Ferrite Core	NiZn Ferrite
②	Wire	Polyester imide enameled copper wire
③	Magnetic Glue	Epoxy resin and magnetic powder
④	Electrodes	Sn Alloy

Fig. 5-1

6 Product Marking

Please refer to Fig. 6-1.

The content of marking please refers to Appendix A.

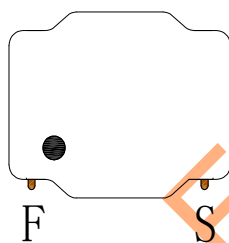

Fig. 6-1

for Automotive Electronics

7 Reliability Test

No.	Test Item	Test Method(According to AEC-Q200)	Requirements
1	Terminal Strength	Reflow 3 times,17.7N(Requirement from AEC-Q200),X, Y direct, 60(+5)s, Speed:1.0mm/s	No removal or split of the termination or other defects shall occur
2	Resistance to Flexure	Reflow 3 times,2mm,60(+5)s.	No visible mechanical damage
3	Temp. Characteristics	-40°C/15(+3)min→+25°C/15(+3)min →+125°C /15(+3)min.	Inductance change should be within ±20% of reference value measuring at 25°C
4	Solderability	Method 1: ①pretreatment:155°C,4h ②245°C,5(-0.5,+0)s. ③Solder: Sn/3.0Ag/0.5Cu.	Wetting shall be exceeded 95% coverage
		Method 2: ①Steam aging:8h. ②245°C,5(-0.5,+0)s. ③Solder: Sn/3.0Ag/0.5Cu.	Wetting shall be exceeded 95% coverage
		Method 3: ①Steam aging:8h. ②260°C,30(-0.5,+0.5)s. ③Solder: Sn/3.0Ag/0.5Cu.	Wetting shall be exceeded 95% coverage
5	Resistance to Soldering Heat	Reflow 3 times, Reflow: Max. 260°C/10s.	(1) No visible mechanical damage (2) Inductance change: Within ±10%
6	High Frequency Vibration	10~2000~10Hz,5g,20min/Cycle,4hours in each 3 mutually perpendicular directions (total of 12hours)	(1) No visible mechanical damage (2) Inductance change: Within ±10%
7	Mechanical Shock	Half sine shock pulse,100g, 6ms, 3 shocks in each 6 mutually perpendicular directions (total of 36 shocks).	(1) No visible mechanical damage (2) Inductance change: Within ±10%
8	ESD Test	HBM ESD discharge waveform,8KV, each 1 time of +/-polarity.	(1) No visible mechanical damage (2) Inductance change: Within ±10%
9	Thermal Shock	Reflow 3 times, -40°C/(30±3min),+125°C /(30±3min), transforming interval:20s(Max.),1000cycles.	(1) No visible mechanical damage (2) Inductance change: Within ±10%
10	Resistance to Low Temperature	Reflow 3 times,-40±2°C, 1000(+24) hours	(1) No visible mechanical damage (2) Inductance change: Within ±10%
11	Resistance to High Temperature	Reflow 3 times,125±2°C,1000(+24)hours	(1) No visible mechanical damage (2) Inductance change: Within ±10%
12	Biased Humidity	Reflow 3 times,85°C, 85%RH,1000h	(1) No visible mechanical damage (2) Inductance change: Within ±10%
13	Operational Life	Reflow 3 times,125±2°C,1000(+24)hours, rated current	(1) No visible mechanical damage (2) Inductance change: Within ±10%
14	Flammability	Refer to UL94.	No undesirable appearance
15	Solvent resistance test	Refer to MIL-STD-202 Method 215	No undesirable appearance

8 Packaging, Storage and Transportation

8.1 Tape and Reel Packaging Dimensions

8.1.1 Taping Dimensions (Unit: mm)

Please refer to Fig. 8.1.1 and Table 8.1.1.

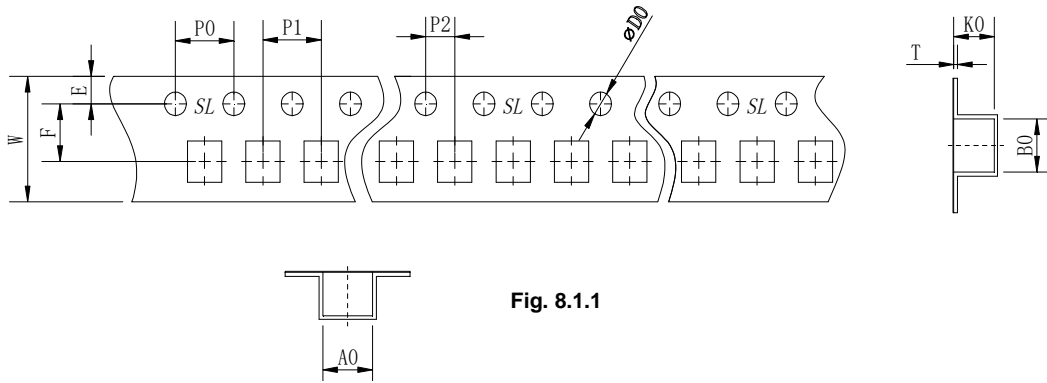

Fig. 8.1.1

[Table 8.1.1]

Series	A ₀	B ₀	W	E	F	P ₀	P ₁	P ₂	D ₀	T	K ₀
AS1A322517	2.8±0.1	3.4±0.1	8.0±0.3	1.75±0.1	3.5±0.05	4.0±0.1	4.0±0.1	2.0±0.1	1.5+0.1/-0.0	0.25±0.05	1.9±0.1

8.1.2 Direction of rolling

Please refer to Fig. 8.1.2

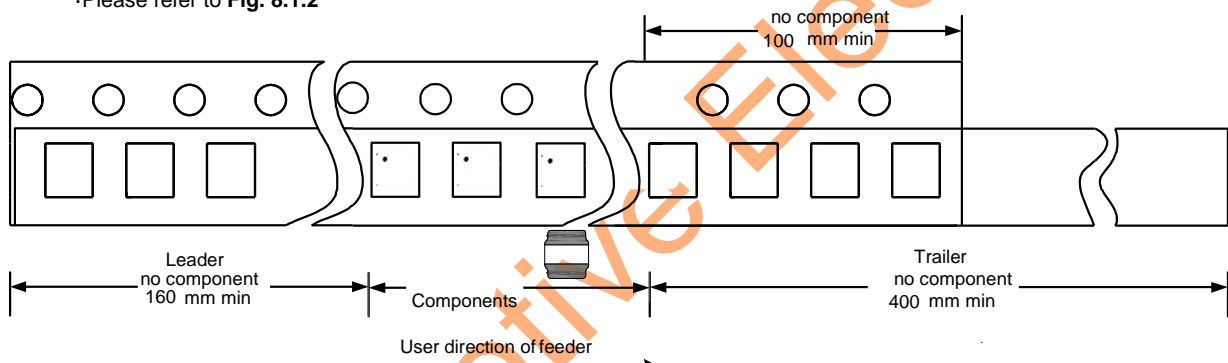

Fig. 8.1.2

8.1.3 Reel Dimensions (Unit: mm)

Please refer to Fig. 8.1.3.

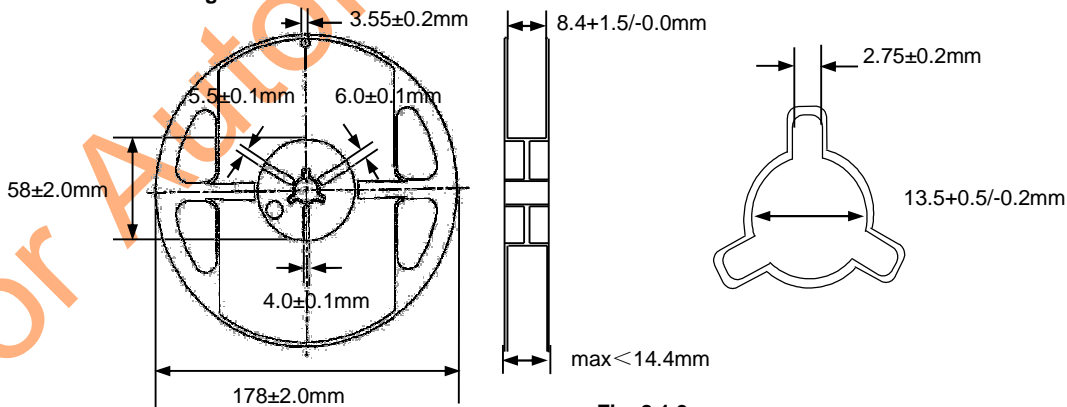

Fig. 8.1.3

8.1.4 Top tape strength

Peel-off strength: 10~130gf.

Peel-off angle: 165°~180° refers to Fig.8.1.4.

Peel-off speed: 300mm/min.

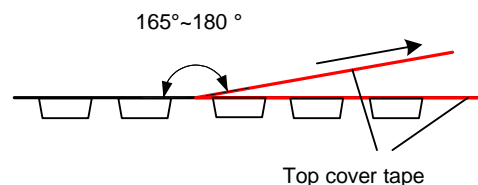

Fig. 8.1.4

8.1.5 The number of components

A tape & reel package contains 2000 inductors.

8.1.6 The allowable number of empty chip cavities

Maximum two (2) chip cavities missing product may exist in a reel but they may not be consecutive two cavities.

8.2 Packing Documents and Marking

8.2.1 Packing Documents

Packing documents include the following:

- 1) Packaging list
- 1) Certificate of compliance (COC)

8.2.2 Packing QTY.

- 1) Inner Box: 10 reels in each box.
- 2) Outer Box: 4 or 8 inner boxes in each outer case.
- 3) 40 or 80 reels in each outer case.

8.2.3 Marking

- 1) Marking label information on reels includes (see Fig.8.2.3-1~2):

Fig.8.2.3-2a: Shipping labels

- a). P/O No.
- b). Customer Part No.
- c). Sunlord Part No.
- d). Quantity.
- e). Lot No.
- f). Date code
- g). Inspection stamp
- h). MFG address as 'Made In China'.

Fig.8.2.3-2b: Production label

- a). P/O No.
- b). Quantity..
- c). Lot No.
- d). Inspe No
- e). Inspection stamp
- f). MFG address as 'Made In China'.
- g). sequence number

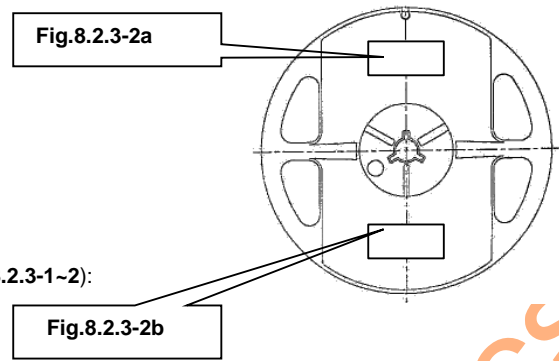

Fig.8.2.3-1

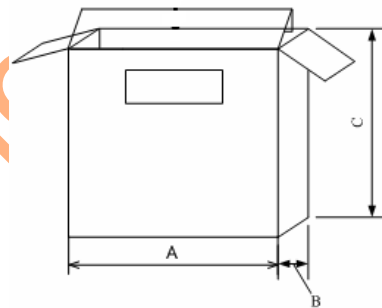

Fig.8.2.3-3

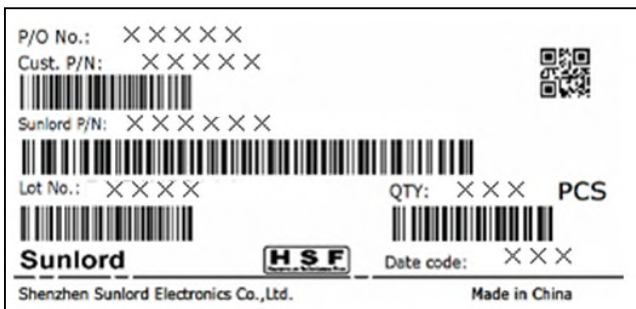

Fig.8.2.3-2a

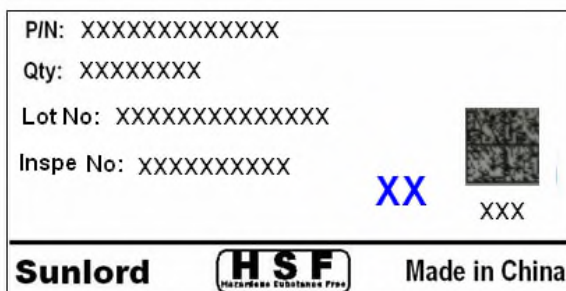

Fig.8.2.3-2b

[Table 8.2.3-1]

Packaging type	A(mm)	B(mm)	C(mm)
Inner box	180	120	180

[Table 8.2.3-2]

Packaging type	L(mm)	W(mm)	H(mm)
TYP1	505	378	200
TYP2	380	260	200

- 2) Marking label information on inner box
 - a). Inner box please refers to Fig.8.2.3-3 and Table 8.2.3-1.
 - b). Marking Label on inner box
N/A.
- 3) Marking on outer case (see Fig.8.2.3-4~6):
 - a). Manufacturer: Sunlord ID:
"Shenzhen Sunlord Electronics Co., Ltd."
 - b). Packing label include the following:
 - i) Customer

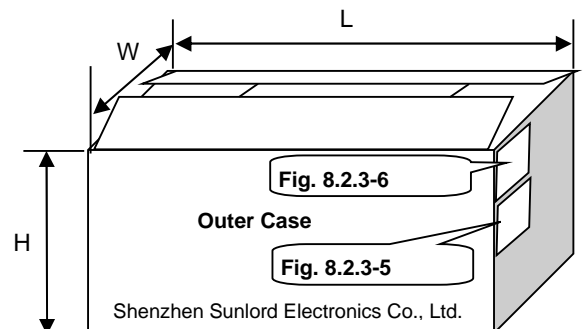

Fig. 8.2.3-4

- ii) Manufacturer
 - iii) Date code
 - iv) C/No.
- Example; "1/10" means that this case is the 1st of total 10 cases
- v) P/O No.
 - vi) Customer Part No.
 - vii) Sunlord Part No.
 - viii) Quantity.
 - ix) Inspection Stamp.

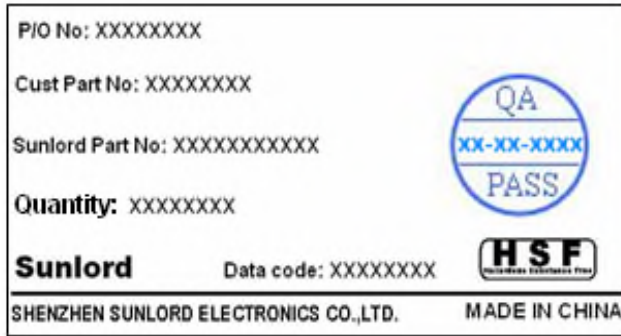

Fig.8.2.3-5

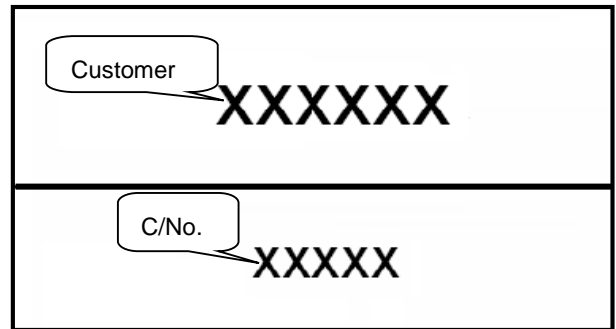
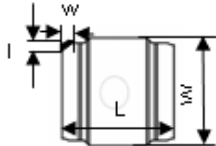
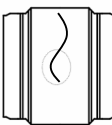
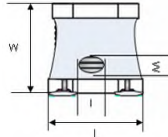
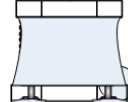
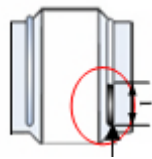
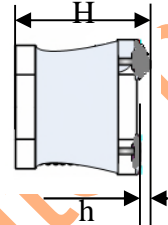
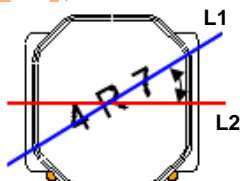

Fig.8.2.3-6

for Automotive Electronics

9 Visual inspection standard of product

File No:		Applied to Wire Wound SMD Power Inductor Series		REV:01
Effective date:				
No.	Defect Item	Graphic	Rejection identification	Acceptance
1	Core defect		The defect length/width (l and w) more than L/6 and W/6, NG.	AQL=0.065
2	Core crack		Visual cracks, NG.	AQL=0.065
3	Starvation		Resin starved length, l, more than L/2, and IF W > 2mm, resin starved width, w, more than W/2, NG. IF W ≤ 2mm, resin starved width, w, don't control.	AQL=0.065
4	Excessive glue		The length, width or height of product beyond specified value, NG.	AQL=0.065
5	Cold solder		Cold solders l more than 1mm, NG.	AQL=0.065
6	Solder icicle		① The height H of product beyond specified value, NG; ② The clearance Δf beyond specified value listed in Item 3, NG;	AQL=0.065
7	Marking defect		① The content of marking 1) is indistinct, 2) disagrees with current product P/N requirements, NG; ② Intersection angle by L1 and L2 more than 45°, NG.	AQL=0.065

10 Recommended Soldering Technologies

10.1 Re-flowing Profile:

- △ Preheat condition: 150 ~200°C/60~120sec.
- △ Allowed time above 217°C: 60~150sec.
- △ Max temp: 260°C
- △ Max time at max temp: 5sec.
- △ Solder paste: Sn/3.0Ag/0.5Cu
- △ Allowed Reflow time: 2x max

Please refer to Fig. 10.1-1.

[Note: The reflow profile in the above table is only for qualification and is not meant to specify board assembly profiles. Actual board assembly profiles must be based on the customer's specific board design, solder paste and process, and should not exceed the parameters as the Reflow profile shows.]

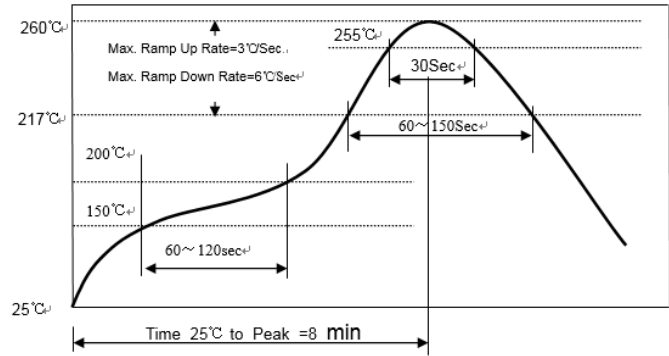

Fig. 10.1-1.

10.2 Iron Soldering Profile:

- △ Iron soldering power: Max. 30W
- △ Pre-heating: 150°C/60sec.
- △ Soldering Tip temperature: 350°C Max.
- △ Soldering time: 3sec. Max.
- △ Solder paste: Sn/3.0Ag/0.5Cu
- △ Max.1 times for iron soldering

Please refer to Fig. 10.2-1.

[Note: Take care not to apply the tip of the soldering iron to the terminal electrodes.]

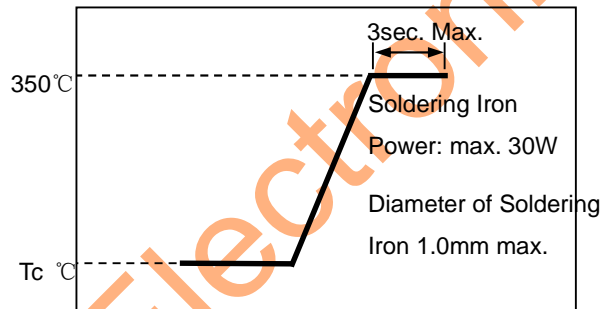

Fig. 10.2-1.

11 Precautions

11.1 Surface mounting

- Mounting and soldering condition should be checked beforehand.
- Applicable soldering process to this product is reflow soldering only.
- Recommended conditions for repair by soldering iron:
 Preheat the circuit board with product to repair at 150°C for about 1 minute.
 Put soldering iron on the land-pattern.
 Soldering iron's temperature: 350°C maximum/Duration: 3 seconds maximum/1 time for each terminal.
 The soldering iron should not directly touch the inductor.
 Product once removes from the circuit board may not be used again.

11.2 Handing

- Keep the products away from all magnets and magnetic objects.
- Be careful not to subject the products to excessive mechanical shocks.
- Please avoid applying impact to the products after mounted on pc board.
- Avoid ultrasonic cleaning.
- It is recommended to use automatic plate division by equipment instead of manual plate splitting to avoid affecting the peeling strength of the electrode.
- Hard tweezers cannot be used to grip the product to avoid blistering or damage to the product coating, and it is recommended to use a suction pen

11.3 Storage

- To maintain the solderability of terminal electrodes and to keep the packing material in good condition, temperature and humidity in the storage area should be controlled.
- Recommended conditions: -10°C~40°C, 70%RH (Max.)
- Even under ideal storage conditions, solderability of products electrodes may decrease as time passes. For this reason, product should be used with one year from the time of delivery.
- In case of storage over 12 months, solderability shall be checked before actual usage.

11.4 Regarding Regulations

- Any Class- I or Class-II ozone-depleting substance (ODS) listed in the Clean Air Act in US for regulation is not included in the products or applied to the products at any stage of whose manufacturing processes.
- Certain brominated flame retardants (PBBs,PBDEs) are not used at all.
- The products of this specification are not subject to the Export Trade Control Order in China or the Export Administration Regulations in US.

11.5 Guarantee

- The guaranteed operating conditions of the products are in accordance with the conditions specified in this specification.
- Please note that Sunlord takes no responsibility for any failure and/or abnormality which is caused by use under other than the aforesaid operating conditions.

Appendix A: Electrical Characteristics

Customer P/N	Part Number	Inductance	Min.	DC Resistance		Saturation Current		Heat Rating Current		Marking
		1MHz/1V	Self-resonant frequency	Max.	Typ.	Max.	Typ.	Max.	Typ.	
	Units	μH	MHz	Ω	Ω	A	A	A	A	
	Symbol	L	SRF	DCR		Isat		Irms		-
	AS1A322517100MT	10.0±20%	24	0.354	0.295	1.20	1.40	0.90	1.20	●

- Note:※ 1: Rated current: Isat (max.) or Irms (max.), whichever is smaller;
 ※ 2: Saturation Current: Max. Value, DC current at which the inductance drops less than 30% from its value without current;
 Typ. Value, DC current at which the inductance drops approximate 30% from its value without current;
 ※ 3: Irms: DC current that causes the temperature rise (ΔT) from 20°C ambient.
 For Max. Value, ΔT<40°C; For Typ. Value, ΔT is approximate 40°C.

The part temperature (ambient + temp. rise) should not exceed 125 °C under worst case operating conditions. Circuit design, component placement, PCB trace size and thickness, airflow and other cooling provisions all affect the part temperature. Part temperature should be verified in the end application.

Typical Electrical Characteristics:

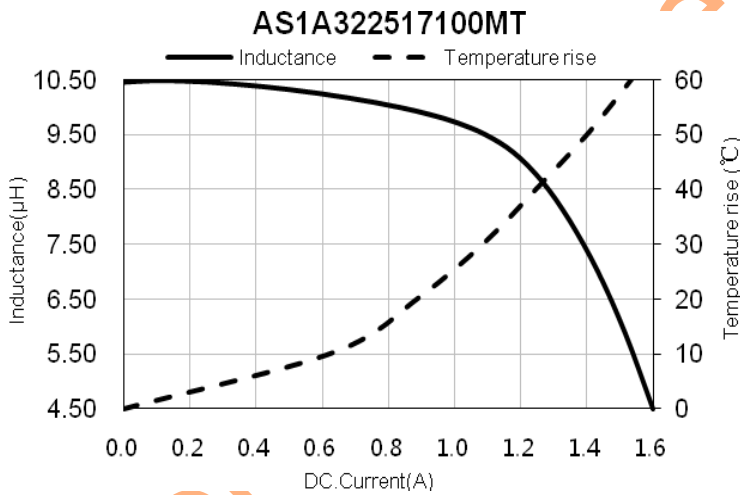

for Auto