

VOLTAGE RANGE
20 to 200 Volts
CURRENT
3.0 Ampere

FEATURES

- * Ideal for surface mount applications
- * Easy pick and place
- * Built-in strain relief
- * Low forward voltage drop

MECHANICAL DATA

- * Case: Molded plastic
- * Epoxy: UL 94V-0 rate flame retardant
- * Metallurgically bonded construction
- * Polarity: Color band denotes cathode end
- * Mounting position: Any

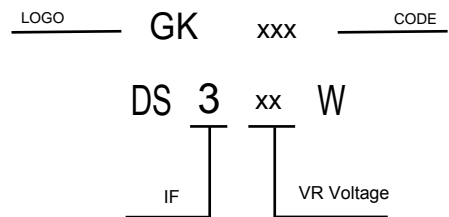

MAXIMUM RATINGS AND ELECTRICAL CHARACTERISTICS

Rating 25°C ambient temperature unless otherwise specified.
Single phase half wave, 60Hz, resistive or inductive load.
For capacitive load, derate current by 20%.

Maximum Ratings

PARAMETER	SYMBOL	UNIT	DS32W	DS34W	DS35W	DS36W	DS38W	DS310W	DS315W	DS320W
Device marking code			DS32W	DS34W	DS35W	DS36W	DS38W	DS310W	DS315W	DS320W
Maximum Repetitive Peak Reverse Voltage	V_{RRM}	V	20	40	50	60	80	100	150	200
Maximum RMS Voltage	V_{RMS}	V	14	28	35	42	56	70	105	140
Maximum DC blocking Voltage	V_{DC}	V	20	40	50	60	80	100	150	200
Maximum Average Forward Rectified Current @ 60Hz sinewave, Resistance load, TL (Fig.1)	$I_{F(AV)}$	A	3.0							
Non-repetitive Peak Forward Surge Current @ t=8.3ms Half-sine wave	I_{FSM}	A	80							
Storage temperature	T_{stg}	°C	-55 ~ +150							
Junction temperature	T_j	°C	-55 ~ +125				-55 ~ +150			
Typical Thermal Resistance	$R_{\theta J-A}$	°C/W	80							
	$R_{\theta J-L}$	°C/W	20							

Electrical Characteristics (Ta=25°C Unless otherwise noted)

PARAMETER	TEST CONDITIONS	SYMBOL	UNIT	DSK32	DSK34	DSK35	DSK36	DSK38	DSK310	DSK315	DSK320
Maximum instantaneous forward voltage	$I_F=3.0A$	V_F	V	0.55		0.70		0.85		0.95	
Maximum DC reverse current at rated DC blocking voltage	$V_R=V_{DC}, T_A=25^\circ C$	I_{R1}	mA	0.2				0.05			
	$V_R=V_{DC}, T_A=100^\circ C$	I_{R2}		20				5			
Typical junction capacitance	4.0V DC, 1MHz	C_j	pF	250				160			

RATING AND CHARACTERISTIC CURVES

FIG.1-TYPICAL FORWARD CURRENT DERATING CURVE

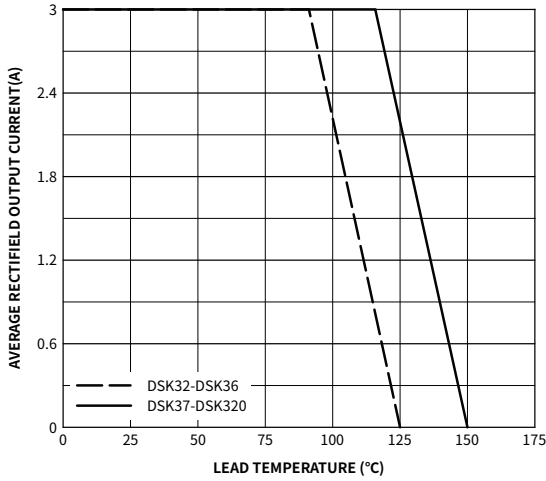

FIG.2-TYPICAL FORWARD CHARACTERISTICS

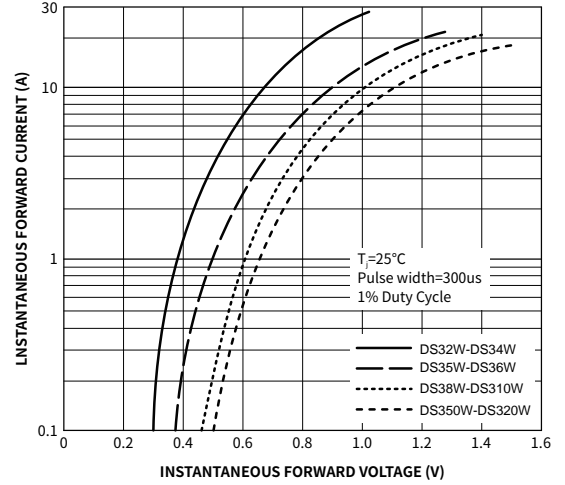

FIG.3 - TYPICAL REVERSE CHARACTERISTICS

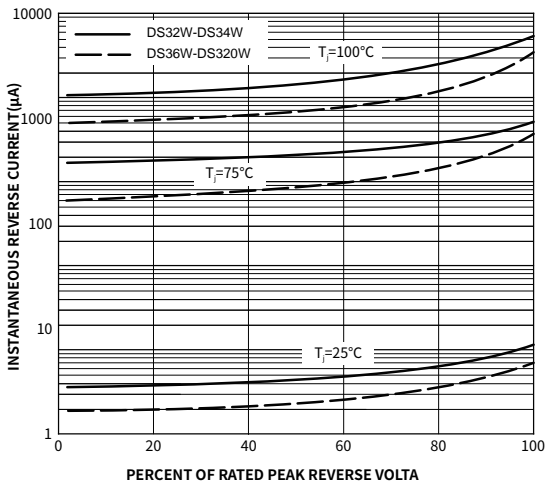
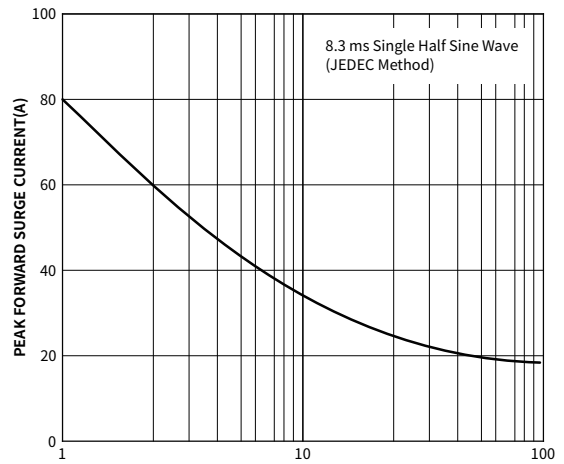

FIG.4-MAXIMUM NON-REPETITIVE FORWARD SURGE CURRENT



Soldering parameters

Reflow Condition		Pb-Free assembly (see as below)
Pre Heat	-Temperature Min ($T_{s(min)}$)	+150 °C
	-Temperature Max ($T_{s(max)}$)	+200 °C
	-Time (Min to Max) (ts)	60-180 secs.
Average ramp up rate (Liquid us Temp (T_L) to peak)		3 °C/sec. Max
$T_{s(max)}$ to T_L - Ramp-up Rate		3 °C/sec. Max
Reflow	-Temperature (T_L) (Liquid us)	+217 °C
	-Temperature (t_L)	60-150 secs.
Peak Temp (T_P)		+260(+0/-5) °C
Time within 5 °C of actual Peak Temp (t_p)		30 secs. Max
Ramp-down Rate		6 °C/sec. Max
Time 25 °C to Peak Temp (T_P)		8 min. Max
Do not exceed		+260 °C



Package Dimensions & Suggested Pad Layout

SOD123FL

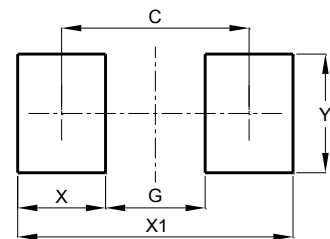
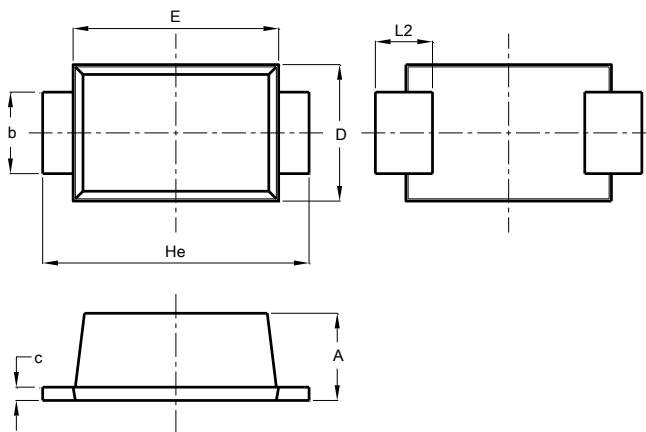

SOD123FL		
Dim	Min	Max
A	1.00	1.20
b	0.80	1.10
c	0.12	0.20
D	1.75	1.95
E	2.60	2.90
He	3.55	3.80
L2	0.50	0.85
All Dimensions in mm		

Dimensions	Value (in mm)
C	3.25
G	2.00
X	1.25
X1	4.50
Y	1.50

Tape & reel specification

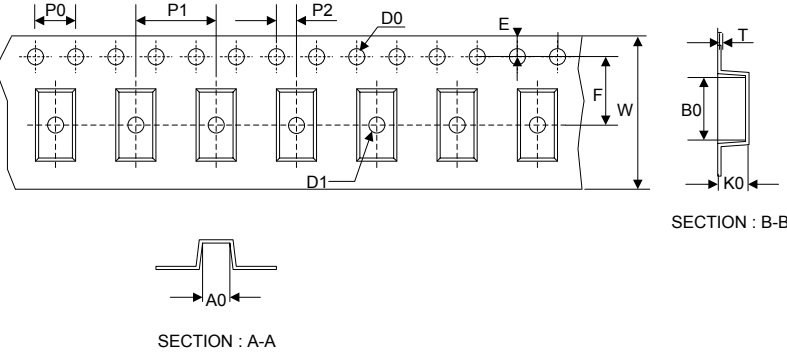
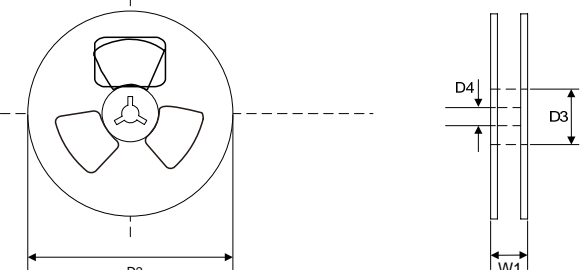
Tape	Symbol	Dimension (mm)
	P0	4.00±0.20
	P1	4.00±0.20
	P2	2.00±0.20
	D0	1.55±0.15
	D1	1.00±0.20
	E	1.75±0.20
	F	3.50±0.25
	W	8.00±0.20
	A0	1.85±0.20
	B0	3.95±0.20
	K0	1.30±0.20
	T	0.21±0.10
	7" Reel	D2
	D3	55.0Min.
	D4	10.0±2.5
	W1	11.5±2.5
	Quantity: 3000PCS	