

General Description:

The LWT1H36A4 uses advanced SGT technology and design to provide excellent $R_{DS(ON)}$ with low gate charge. It can be used in a wide variety of applications. The package form is TO-252, which accords with the ROHS standard and Halogen Free standard.

Features:

- Fast Switching
- Low Gate Charge and $R_{DS(ON)}$
- Low Reverse transfer capacitances

Applications:

- Battery switching application
- Hard switched and high frequency circuits
- Power Management

100% DVDS Tested

100% Avalanche Tested

Package Marking and Ordering Information:

Marking	Part Number	Package	Packing	Qty.
T1H36/LW A4/D.C.	LWT1H36A4	TO-252	Reel	2500 Pcs

Absolute Maximum Ratings:

Symbol	Parameter	Value	Units
V_{DSS}	Drain-to-Source Voltage	100	V
I_D	Continuous Drain Current	$T_C=25^\circ\text{C}$	28
	Continuous Drain Current	$T_C=100^\circ\text{C}$	18
I_{DM}^{a1}	Pulsed Drain Current	112	A
E_{AS}^{a2}	Single pulse avalanche energy	22	mJ
V_{GS}	Gate-to-Source Voltage	± 20	V
P_D	Power Dissipation	50	W
T_J, T_{STG}	Operating Junction and Storage Temperature Range	150, -55 to 150	$^\circ\text{C}$
T_L	Maximum Temperature for Soldering	260	$^\circ\text{C}$

Thermal Characteristics:

Symbol	Parameter	Value	Units
$R_{\theta JC}$	Thermal Resistance, Junction-to-Case	2.5	$^\circ\text{C}/\text{W}$
$R_{\theta JA}^{a3}$	Thermal Resistance, Junction-to-Ambient	50	$^\circ\text{C}/\text{W}$

V_{DSS}	100	V
I_D	28	A
P_D	50	W
$R_{DS(ON) \text{ TYPE}}$	26	$\text{m}\Omega$

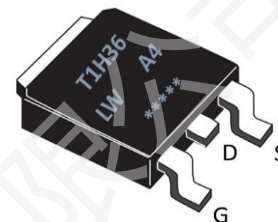
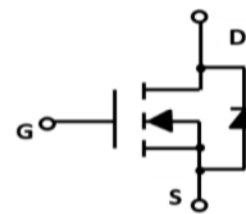
Marking and Pin Assignment

Inner Equivalent Principium Chart

Electrical Characteristic ($T_j = 25\text{ }^\circ\text{C}$, unless otherwise specified):

Static Characteristics						
Symbol	Parameter	Test Conditions	Value			Units
			Min.	Typ.	Max.	
V_{DSS}	Drain to Source Breakdown Voltage	$V_{GS}=0V, I_D=250\mu A$	100	--	--	V
I_{DSS}	Drain to Source Leakage Current	$V_{DS}=100V, V_{GS}=0V$	--	--	1.0	μA
$I_{GSS(F)}$	Gate to Source Forward Leakage	$V_{GS}=+20V, V_{DS}=0V$	--	--	100	nA
$I_{GSS(R)}$	Gate to Source Reverse Leakage	$V_{GS}=-20V, V_{DS}=0V$	--	--	-100	nA
$V_{GS(TH)}$	Gate Threshold Voltage	$V_{DS}=V_{GS}, I_D=250\mu A$	1.3	1.8	2.3	V
$R_{DS(ON)1}$	Drain-to-Source On-Resistance	$V_{GS}=10V, I_D=10A$	--	26	32	$m\Omega$
$R_{DS(ON)2}$	Drain-to-Source On-Resistance	$V_{GS}=4.5V, I_D=8.0A$	--	33	42	$m\Omega$

Dynamic Characteristics						
Symbol	Parameter	Test Conditions	Value			Units
			Min.	Typ.	Max.	
C_{iss}	Input Capacitance	$V_{GS}=0V$	--	472	--	pF
C_{oss}	Output Capacitance	$V_{DS}=50V$	--	150	--	
C_{rss}	Reverse Transfer Capacitance	$f=1.0MHz$	--	3.4	--	
R_G	Gate resistance	$V_{GS}=0V, V_{DS}=0V, f=1MHz$	--	3.8	--	Ω

Resistive Switching Characteristics						
Symbol	Parameter	Test Conditions	Value			Units
			Min.	Typ.	Max.	
$t_{d(ON)}$	Turn-on Delay Time	$I_D=10A$	--	6.3	--	ns
t_r	Rise Time	$V_{DS}=50V$	--	22	--	
$t_{d(OFF)}$	Turn-Off Delay Time	$V_{GS}=10V$	--	39	--	
t_f	Fall Time	$R_G=8.2\Omega$	--	14	--	
Q_g	Total Gate Charge	$V_{GS}=10V$	--	10	--	nC
Q_{gs}	Gate to Source Charge	$V_{DS}=50V$	--	2.1	--	
Q_{gd}	Gate to Drain Charge	$I_D=10A$	--	2.1	--	

Source-Drain Diode Characteristics						
Symbol	Parameter	Test Conditions	Value			Units
			Min.	Typ.	Max.	
I_S	Diode Forward Current	$T_C=25\text{ }^\circ\text{C}$	--	--	28	A
V_{SD}	Diode Forward Voltage	$I_S=10A, V_{GS}=0V$	--	--	1.2	V
t_{rr}	Reverse Recovery Time	$I_S=10A, V_{DD}=50V$	--	35	--	ns
Q_{rr}	Reverse Recovery Charge	$dI/dt=100A/\mu s$	--	38	--	nC

a1: Repetitive rating; pulse width limited by maximum junction temperature

a2: $V_{DD}=50V, L=0.1mH, R_G=25\Omega$, Starting $T_j=25\text{ }^\circ\text{C}$

a3: Device on 40 mm x 40 mm x 1.5 mm epoxy PCB FR4 with 6 cm² (one layer, 70 μm thick) copper area for drain connection.

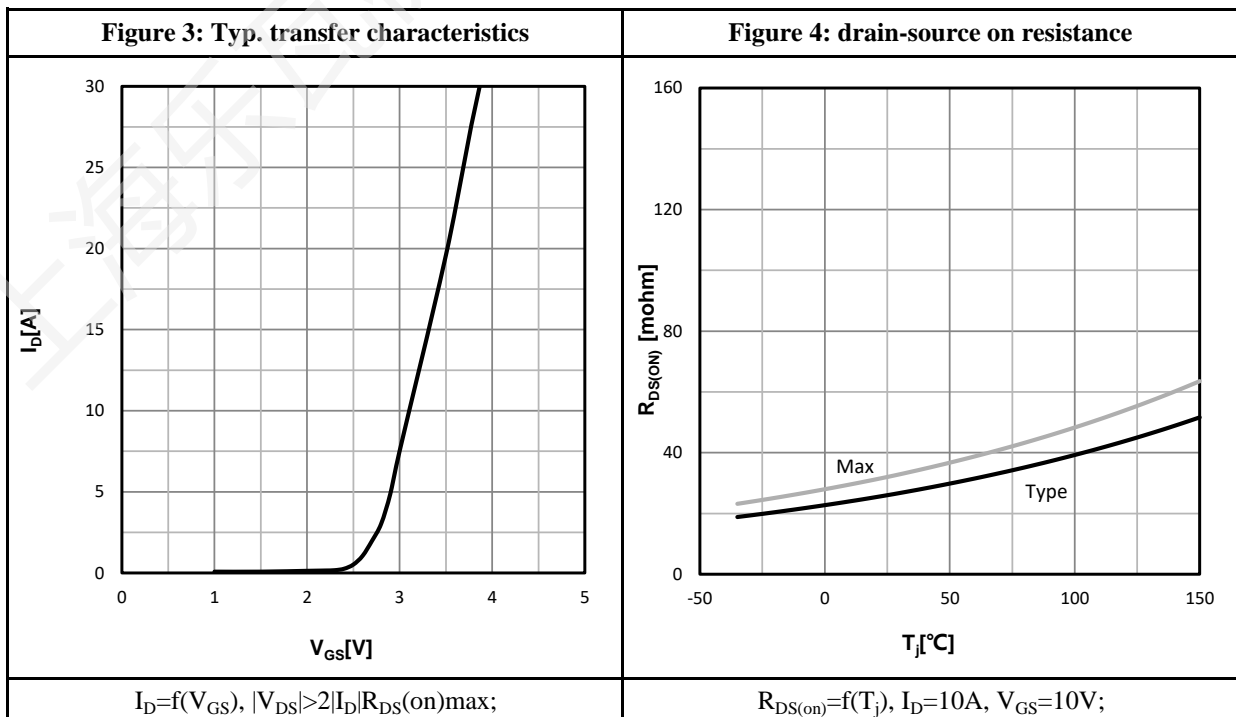
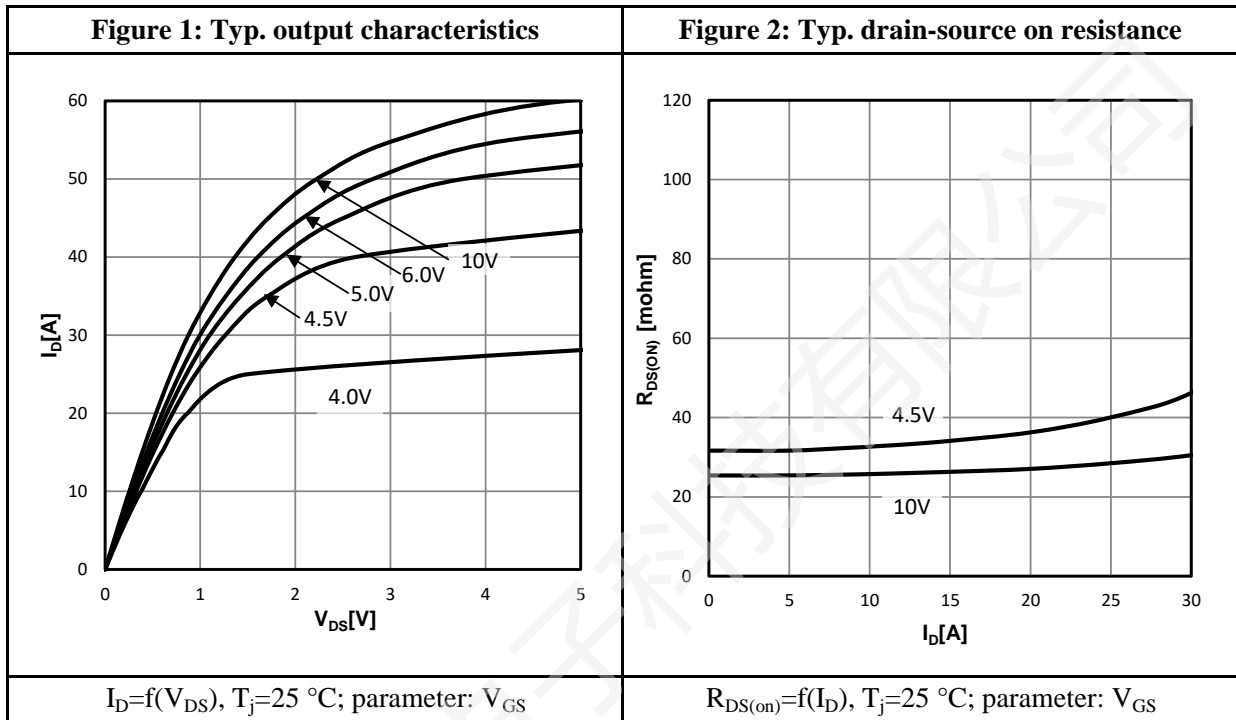
Characteristics Curve:

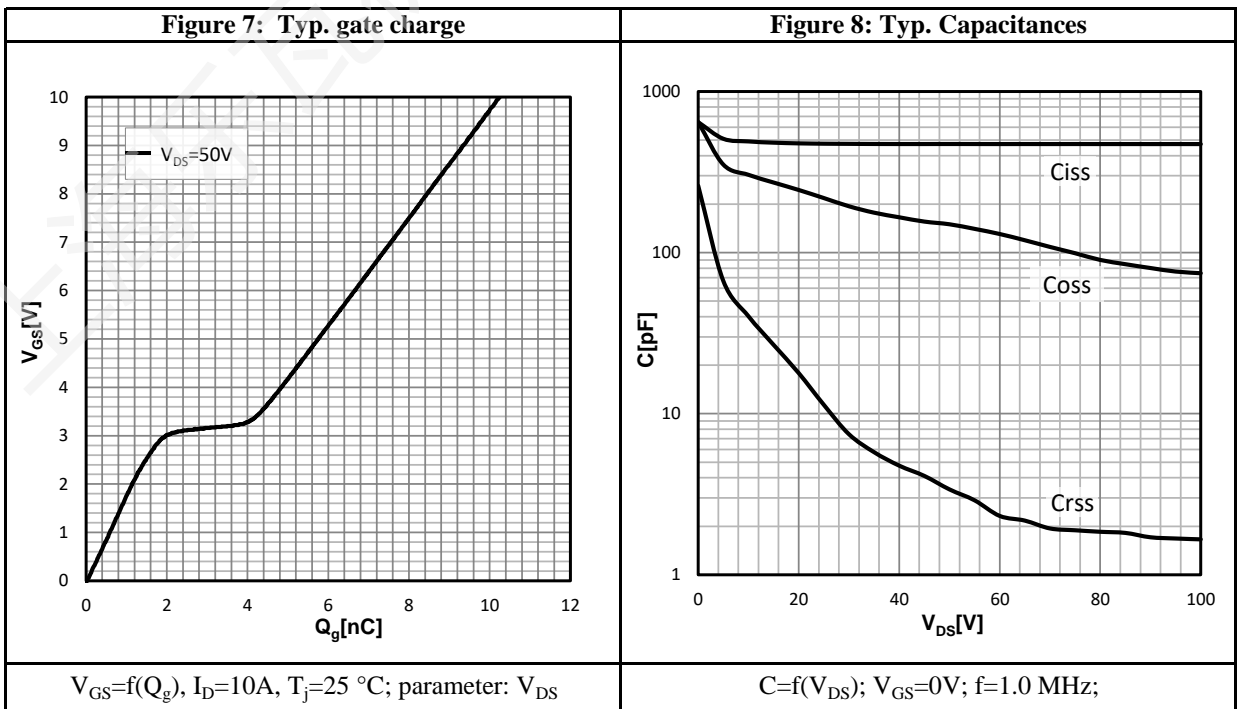
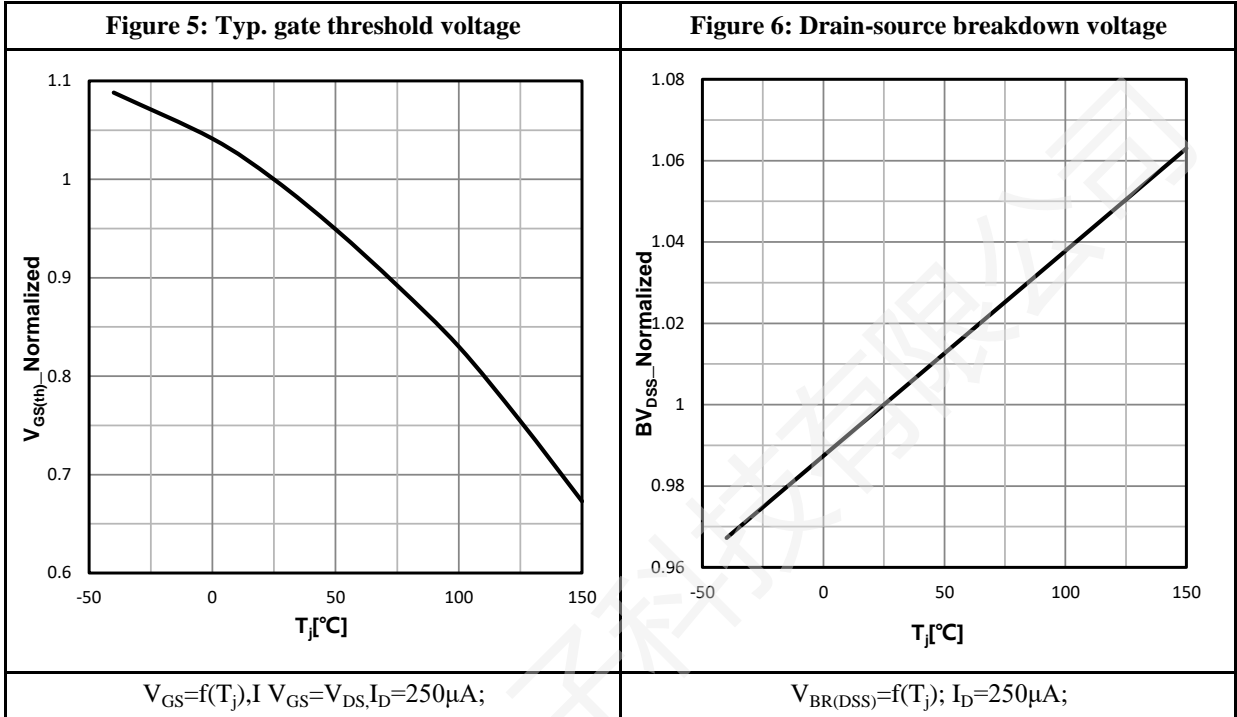

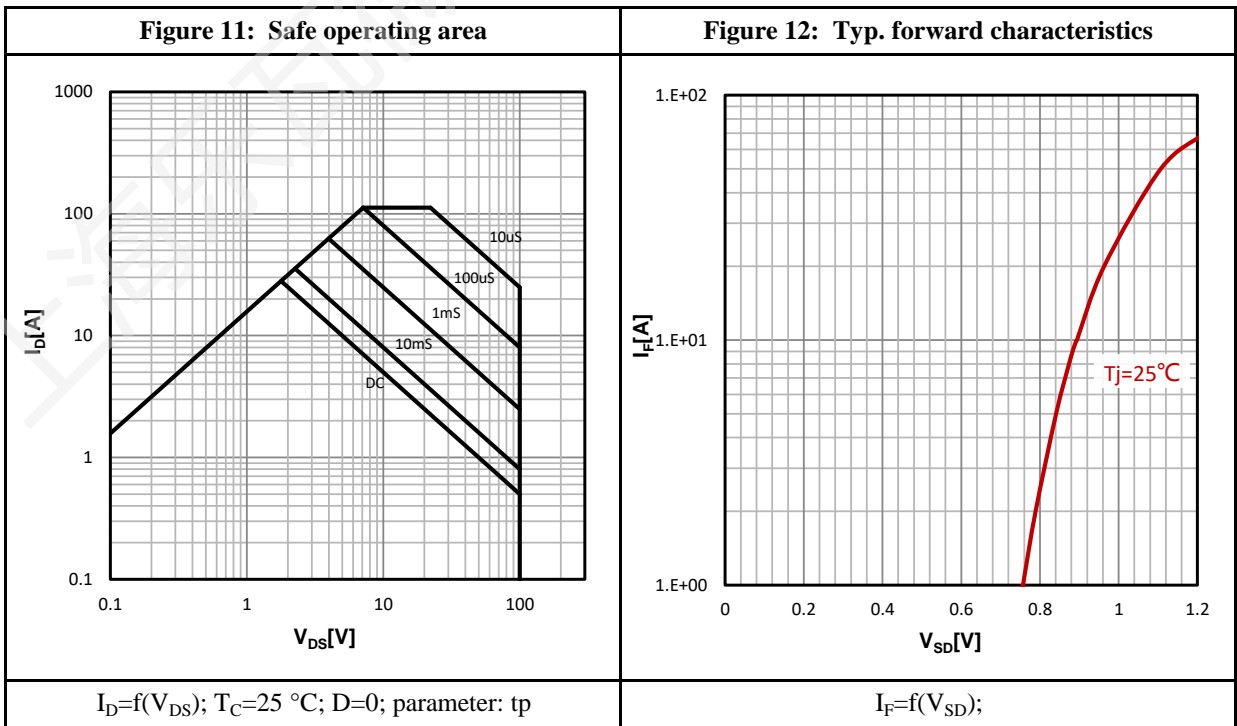
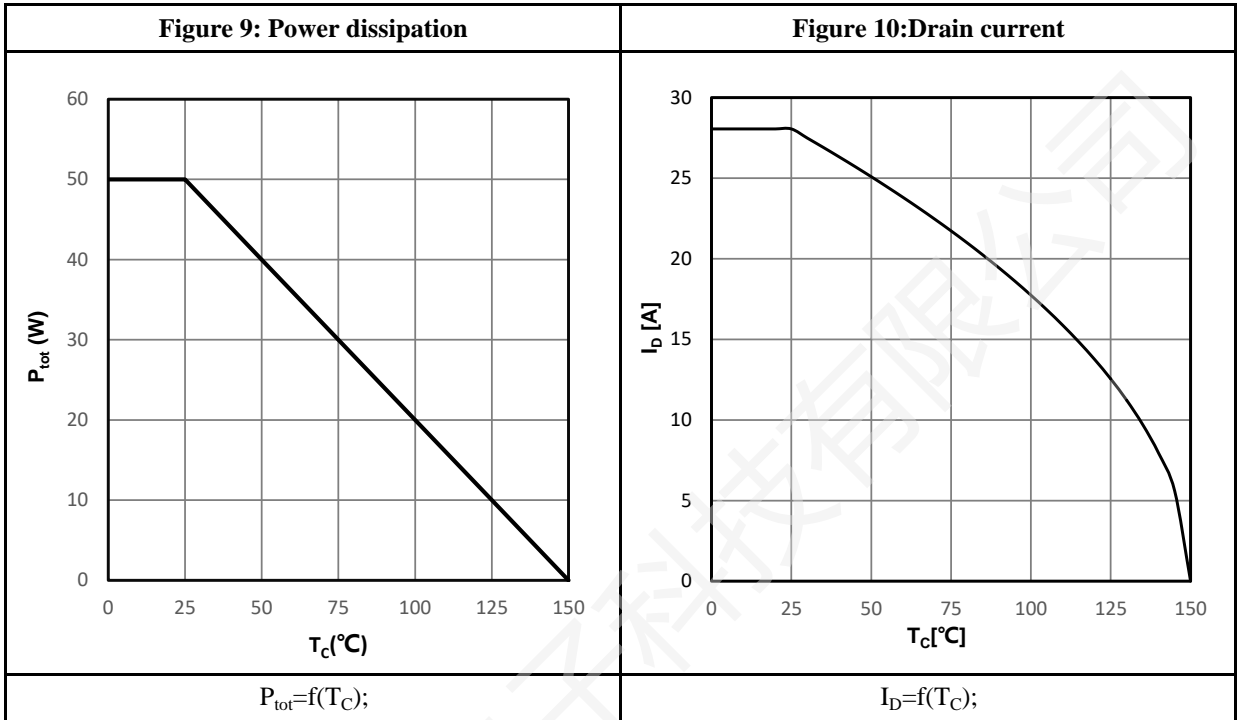

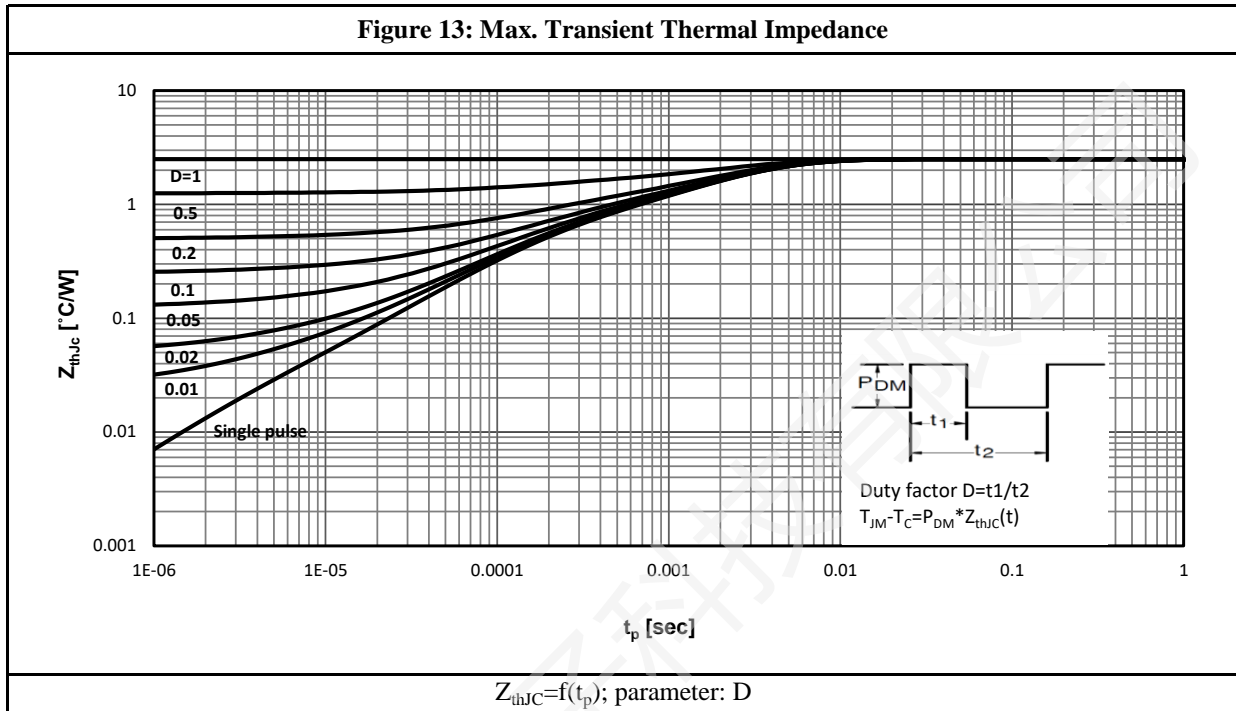

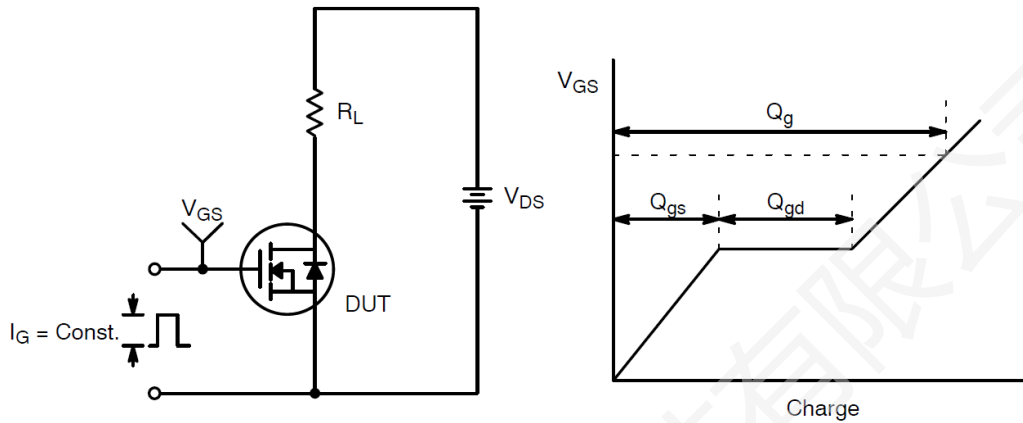
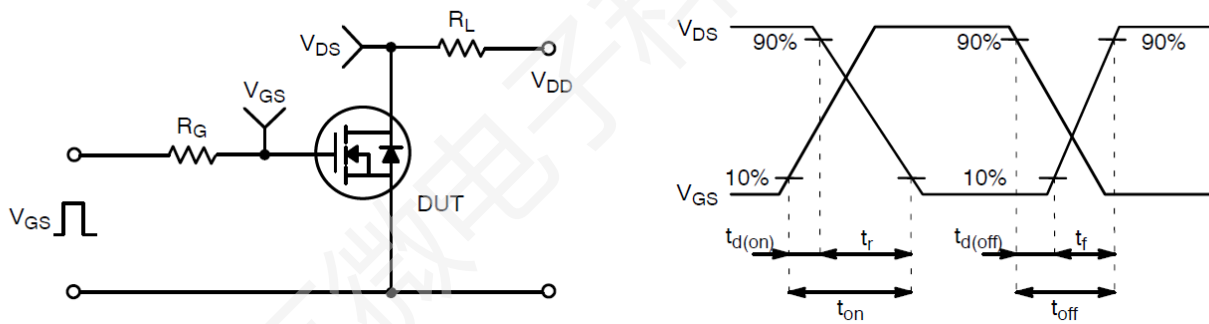
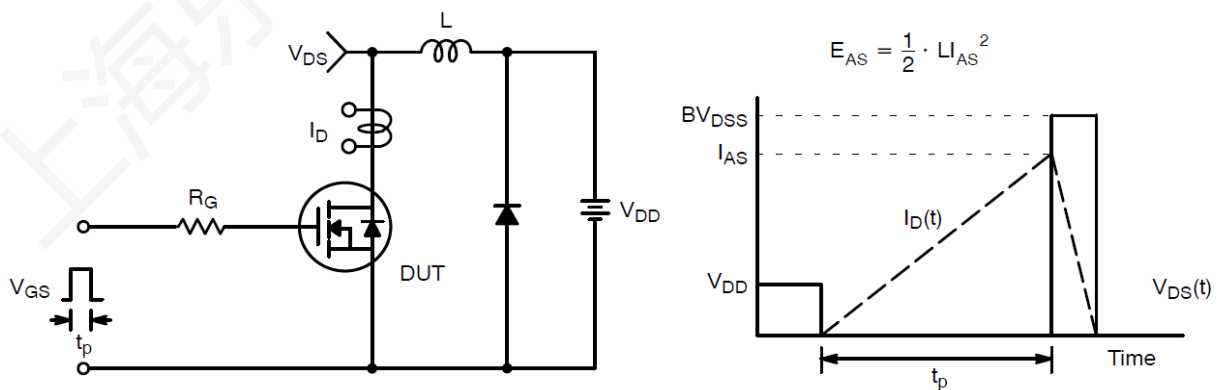
Test Circuit & Waveform:

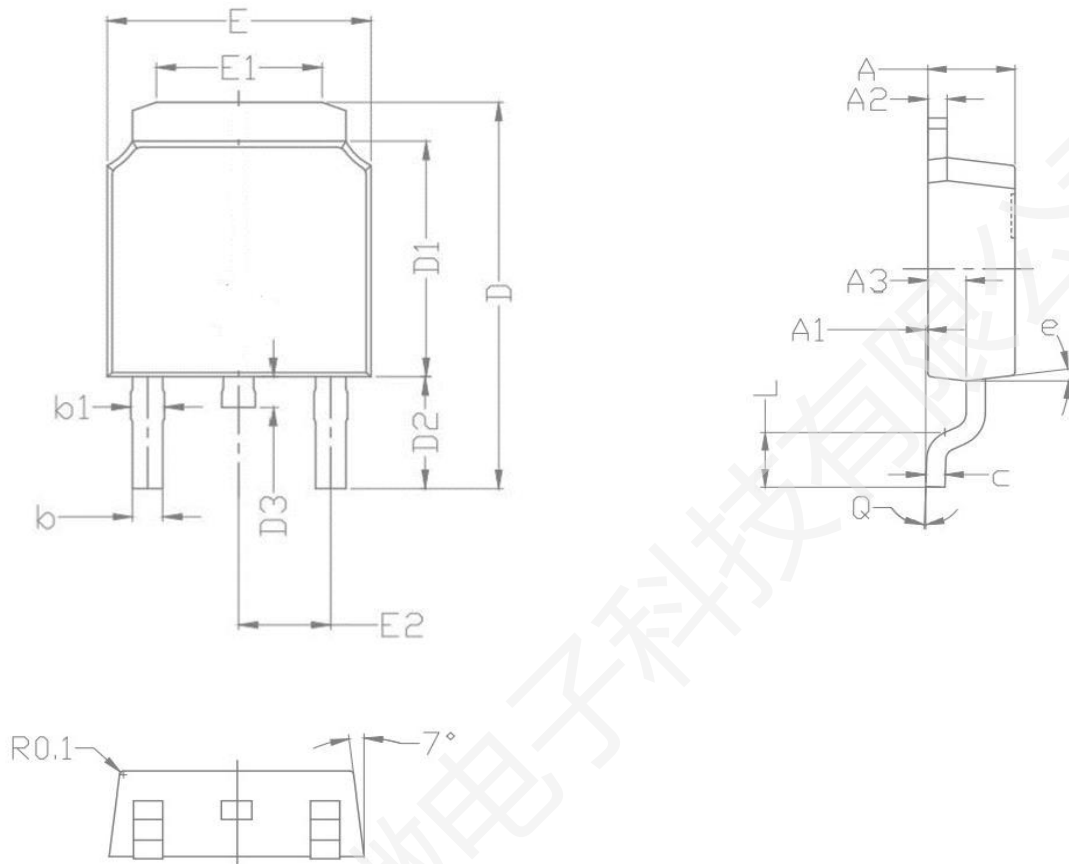
Figure 14: Gate Charge Test Circuit & Waveform

Figure 15: Resistive Switching Test Circuit & Waveforms

Figure 16: Unclamped Inductive Switching Test Circuit & Waveforms

Package Outline:

COMMON			
PKG	TO-252		
Symbol	Min	Nom	Max
A	2.200	2.300	2.400
A1	0.000	0.075	0.150
A2	0.460	0.525	0.590
A3	0.960	1.010	1.060
b	0.640	0.720	0.800
C	0.450	0.515	0.580
D	9.800	10.025	10.350
D1	6.000	6.100	6.200
D2	2.850	2.900	3.100
D3	0.490	0.800	1.000
E	6.400	6.550	6.700
E1	4.050	4.130	4.600
E2	2.250	2.286	2.300
L	1.400	1.550	1.700
e	7°	8°	9°
Q	0°	5°	10°

Revision History:

Revison	Date	Descriptions
Rev 1.0	Mar.2025	Initial Version

Disclaimer:

- The product is not intended for use in applications that require extraordinary levels of quality and reliability, such as military, aviation/aerospace and life-support systems or other applications whose failure can be reasonably expected to result in serious physical or material damage.
- Lewa-Micro assumes no responsibility for equipment failures that result from using products at parameters that exceed, even momentarily, rated values (such as maximum ratings, operating condition ranges, or other parameters) listed in products specifications of any Lewa-Micro products described or contained herein.
- Specifications of any and all Lewa-Micro products described or contained herein stipulate the performance, characteristics, and functions of the described products in the independent state, and are not guarantees of the performance, characteristics, and functions of the described products as mounted in the customer's products or equipment. To verify symptoms and states that cannot be evaluated in an independent device, the customer should always evaluate and test devices mounted in the customer's products or equipment.
- Lewa-Micro strives to supply high-quality and high-reliability products. However, any and all semiconductor products have a certain probability of failure. It is possible that these probabilistic failures could give rise to accidents or events that could endanger human lives, that could give rise to smoke or fire, or that could cause damage to other property. When designing equipment, adopt safety measures so that these kinds of accidents or events cannot occur. Such measures including but not limited to protective circuits and error prevention circuits for safe design, redundant design, and structural design.
- To comply with the compliance requirements of relevant export control laws and regulations, if any Lewa-Micro product (including technical data and services) stated herein is subject to relevant export control laws and regulations, it is recommended that the customer apply for and obtain an export license from the competent authority in advance in accordance with the requirements of relevant laws, and do not conduct export activities without obtaining the license. If the customer fails to comply with the aforementioned compliance requirements, all legal liabilities arising therefrom shall be borne solely by the customer.
- To protect Lewa-Micro's intellectual property rights and the security of commercial information, without the prior written permission of Lewa-Micro, no part of this document shall be reproduced or disseminated in any form or by any means (including photocopying, recording, and other electronic or mechanical means, as well as various information storage and retrieval systems). For unauthorized reproduction or dissemination, Lewa-Micro reserves the right to pursue legal liability.
- Information (including circuit diagrams and circuit parameters) herein is for example only; it is not guaranteed for volume production. Lewa-Micro believes information herein is accurate and reliable, but no guarantees are made or implied regarding its use or any infringements of intellectual property rights or other rights of third parties.
- Any and all information described or contained herein are subject to change without notice due to product/technology improvement, etc.

Mailing Address: Unit 02&04&05, 10th Floor, Building 5, No.666 Shengxia Road, No.122 Yindong Road,
China (Shanghai) Pilot Free Trade Zone
Shanghai Lewa Micro-electronics Technology Co., Ltd