



FEATURES

- 30V, 150A
 $R_{DS(ON)}$ Typ = 1.5m Ω @ $V_{GS} = 10V$
 $R_{DS(ON)}$ Typ = 2.4m Ω @ $V_{GS} = 4.5V$
- Excellent $R_{DS(ON)}$ and Low Gate Charge
- Halogen-free; RoHS-compliant
- Pb-free plating

Applications

- Load Switch
- PWM Application
- Power Management

Pin Description

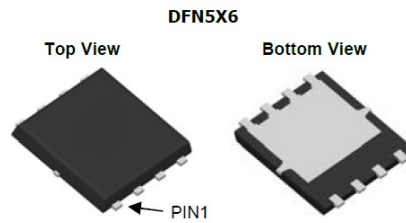

Top View

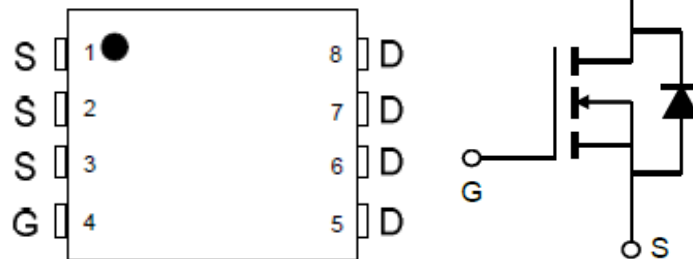

NO.	Symbol	Description
1	S	SOURCE
2	S	SOURCE
3	S	SOURCE
4	G	GATE
5	D	DRAIN
6	D	DRAIN
7	D	DRAIN
8	D	DRAIN



Absolute Maximum Ratings

(@ $T_C = 25^\circ\text{C}$ unless otherwise specified)

Symbol	Parameter	Value	Units	
V_{DS}	Drain-to-Source Voltage	30	V	
V_{GS}	Gate-to-Source Voltage	± 20	V	
I_D	Continuous Drain Current	$T_C = 25^\circ\text{C}$	150	A
		$T_C = 100^\circ\text{C}$	90	
I_{DM}	Pulsed Drain Current ⁽¹⁾	600	A	
E_{AS}	Single Pulsed Avalanche Energy ⁽²⁾	289	mJ	
P_D	Power Dissipation	$T_C = 25^\circ\text{C}$	79	W
$R_{\theta JC}$	Thermal Resistance, Junction to Case	1.57	$^\circ\text{C}/\text{W}$	
T_J, T_{STG}	Junction & Storage Temperature Range	-55 to 150	$^\circ\text{C}$	



Electrical Characteristics

(T_J = 25°C unless otherwise specified)

Symbol	Parameter	Conditions	Min.	Typ.	Max.	Unit
Off Characteristics						
V _{(BR)DSS}	Drain-Source Breakdown Voltage	I _D =250uA, V _{GS} =0V	30	-	-	V
I _{DSS}	Zero Gate Voltage Drain Current	V _{DS} =40V, V _{GS} =0V	-	-	1.0	uA
I _{GSS}	Gate-Body Leakage Current	V _{DS} =0V, V _{GS} =±20V	-	-	±100	nA
On Characteristics						
V _{GS(th)}	Gate Threshold Voltage	V _{DS} =V _{GS} , I _D =250uA	1.1	1.6	2.2	V
R _{DS(ON)}	Static Drain-Source ON-Resistance ⁽³⁾	V _{GS} =10V, I _D =20A	-	1.5	2	mΩ
		V _{GS} =4.5V, I _D =10A	-	2.4	3.2	mΩ
Dynamic Characteristics						
C _{iss}	Input Capacitance	V _{GS} =0V, V _{DS} =20V, f=1MHz	-	5120	-	pF
C _{oss}	Output Capacitance		-	600	-	pF
C _{rss}	Reverse Transfer Capacitance		-	445	-	pF
Q _g	Total Gate Charge	V _{GS} =0~10V, V _{DS} =20V, I _D =30A	-	97	-	nC
Q _{gs}	Gate Source Charge		-	20	-	nC
Q _{gd}	Gate Drain("Miller") Charge		-	23	-	nC
Switching Characteristics						
t _{d(on)}	Turn-On DelayTime	V _{GS} =10V, V _{DD} =20V, I _D =30A, R _{GEN} =3Ω	-	16	-	ns
t _r	Turn-On Rise Time		-	30	-	ns
t _{d(off)}	Turn-Off DelayTime		-	54	-	ns
t _f	Turn-Off Fall Time		-	19	-	ns
Drain-Source Diode Characteristics and Max Ratings						
I _S	Maximum Continuous Drain to Source Diode Forward Current		-	-	150	A
I _{SM}	Maximum Pulsed Drain to Source Diode Forward Current		-	-	600	A
V _{SD}	Drain to Source Diode Forward Voltage	V _{GS} =0V, I _S =30 A	-	-	1.2	V
t _{rr}	Body Diode Reverse Recovery Time	I _F =30A, di/dt=100A/us	-	23	-	ns
Q _{rr}	Body Diode Reverse Recovery Charge		-	14	-	nC

Notes:

- 1.Repetitive Rating: Pulse Width Limited by Maximum Junction Temperature.
- 2.E_{AS} condition: Starting T_J=25°C, V_{DD}=15V, V_G=10V, R_G=25Ω, L=0.5mH, I_{AS}=34A
- 3.Pulse Test: Pulse Width≤300us, Duty Cycle≤0.5%.



Test Circuit

Figure 1: Gate Charge Test Circuit & Waveform

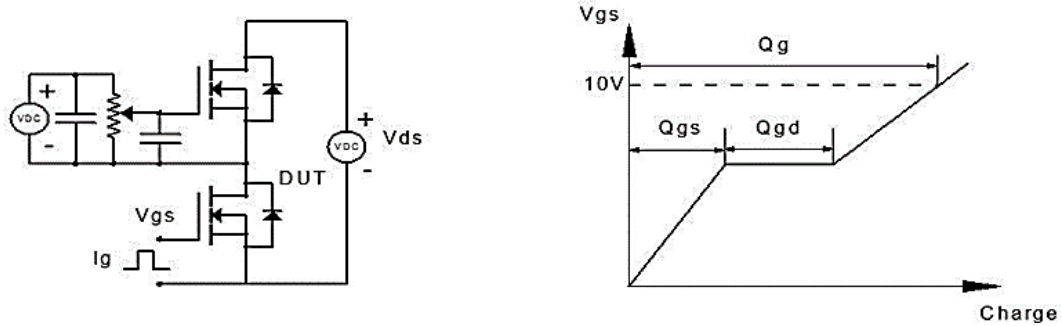

Figure 2: Resistive Switching Test Circuit & Waveform

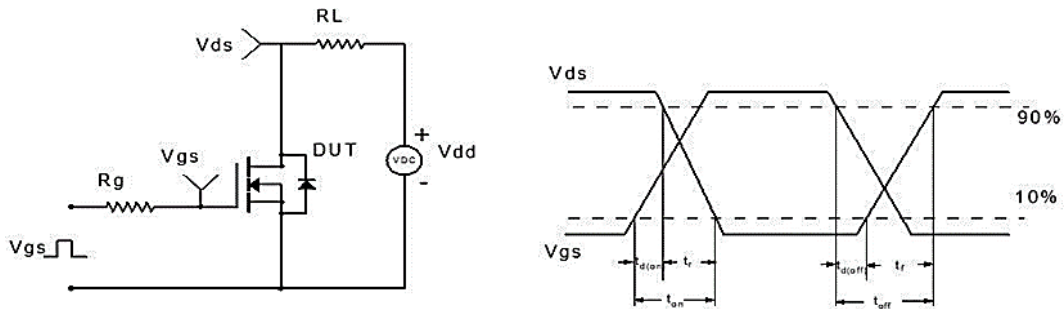

Figure 3: Unclamped Inductive Switching Test Circuit & Waveform

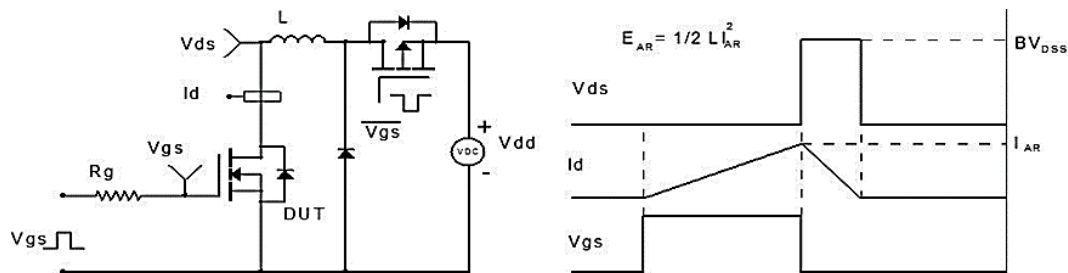
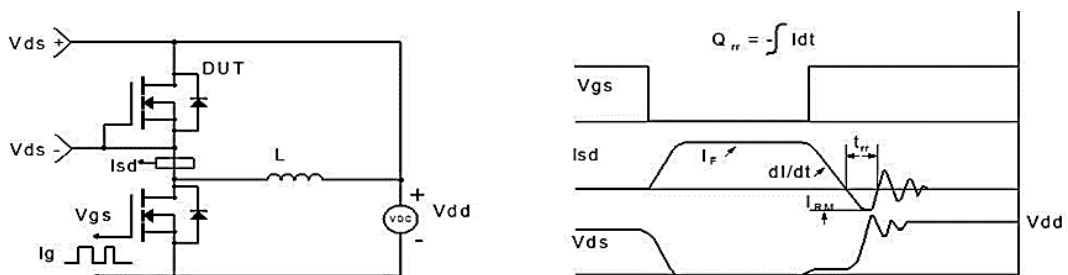
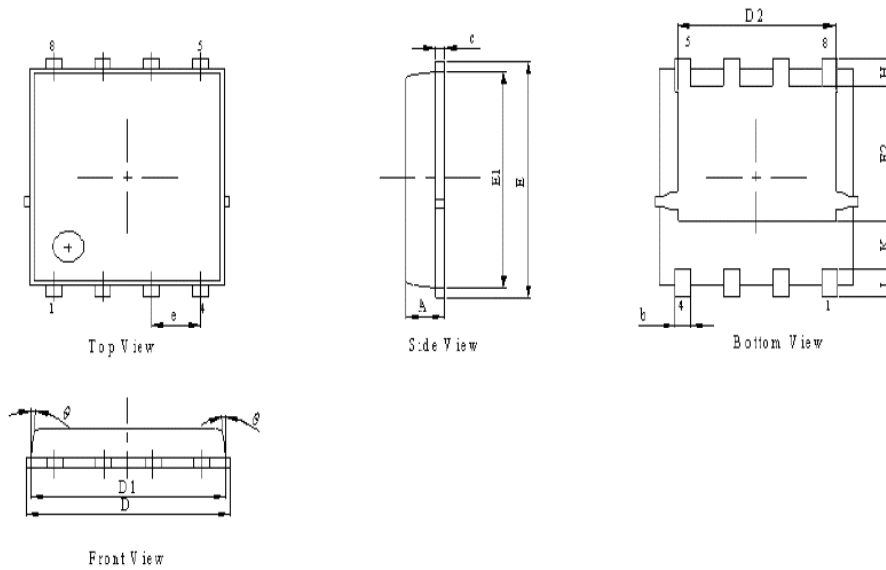

Figure 4: Diode Recovery Test Circuit & Waveform





Package Mechanical Data(PDFN 5x6-8L)



Symbol	Dimensions In Millimeters		
	Min.	NOM.	Max.
A	0.9	1	1.15
b	0.31	0.41	0.51
C	0.24	0.32	0.4
D	5	5.2	5.4
D1	4.95	5.05	5.15
D2	4	4.1	4.2
E	6.05	6.15	6.25
E1	5.5	5.6	5.7
E2	3.42	3.53	3.63
e	1.27 BSC		
H	0.6	0.7	0.8
L	0.5	0.7	0.8
K	1.23 BEF		
O			10

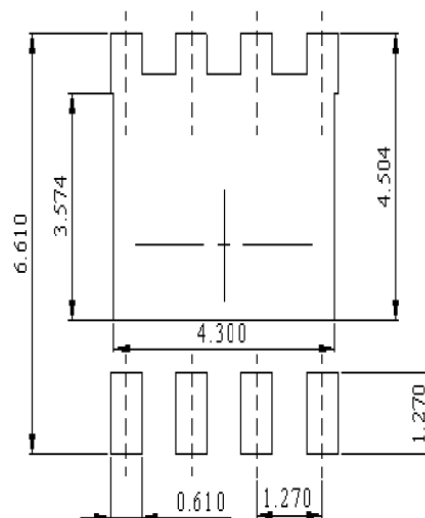

DIMENSIONS: MILLIMETERS



Ordering information

Order Code	Package	V _{DS} (V)	I _D (A)	R _{DS(ON)} (mΩ)	
QNN240N03AX	PDFN 5x6-8	30	150	V _{GS} =10V	1.5
				V _{GS} =4.5V	2.4