



QNHCHIP

QNM30N06AJ

# Product Specification

QNM30N06AJ

---

60V N-Channel MOSFET



## FEATURES

- 60V, 15A  
 $R_{DS(ON)}$  TYP. = 29m $\Omega$  @  $V_{GS} = 10V$   
 $R_{DS(ON)}$  TYP. = 34m $\Omega$  @  $V_{GS} = 4.5V$
- Advanced Trench Technology
- Excellent  $R_{DS(ON)}$  and Low Gate Charge
- Lead Free

## Applications

- Load Switch
- PWM Application
- Power Management

## Pin Description

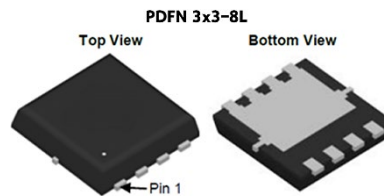

### Top View

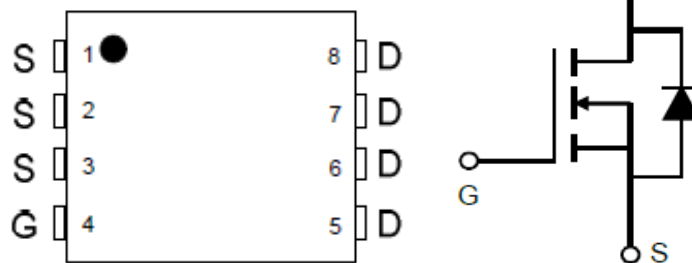

NO.	Symbol	Description
1	S	SOURCE
2	S	SOURCE
3	S	SOURCE
4	G	GATE
5	D	DRAIN
6	D	DRAIN
7	D	DRAIN
8	D	DRAIN



## Absolute Maximum Ratings

(@  $T_C = 25^\circ\text{C}$  unless otherwise specified)

Symbol	Parameter	Value	Units	
$V_{DS}$	Drain-to-Source Voltage	60	V	
$V_{GS}$	Gate-to-Source Voltage	$\pm 20$	V	
$I_D$	Continuous Drain Current	$T_C = 25^\circ\text{C}$	15	A
		$T_C = 100^\circ\text{C}$	9	
$I_{DM}$	Pulsed Drain Current <sup>(1)</sup>	60	A	
$E_{AS}$	Single Pulsed Avalanche Energy <sup>(2)</sup>	25	mJ	
$P_D$	Power Dissipation	$T_C = 25^\circ\text{C}$	20	W
$R_{\theta JC}$	Thermal Resistance, Junction to Case	6.2	$^\circ\text{C}/\text{W}$	
$T_J, T_{STG}$	Junction & Storage Temperature Range	-55 to 150	$^\circ\text{C}$	



## Electrical Characteristics

( $T_J = 25^\circ\text{C}$  unless otherwise specified)

Symbol	Parameter	Conditions	Min.	Typ.	Max.	Unit
<b>Off Characteristics</b>						
$V_{(BR)DSS}$	Drain-Source Breakdown Voltage	$I_D=250\mu\text{A}, V_{GS}=0\text{V}$	60	-	-	V
$I_{DSS}$	Zero Gate Voltage Drain Current	$V_{DS}=60\text{V}, V_{GS}=0\text{V}$	-	-	1.0	$\mu\text{A}$
$I_{GSS}$	Gate-Body Leakage Current	$V_{DS}=0\text{V}, V_{GS}=\pm 20\text{V}$	-	-	$\pm 100$	nA
<b>On Characteristics</b>						
$V_{GS(th)}$	Gate Threshold Voltage	$V_{DS}=V_{GS}, I_D=250\mu\text{A}$	1.0	1.6	2.5	V
$R_{DS(ON)}$	Static Drain-Source ON-Resistance <sup>(4)</sup>	$V_{GS}=10\text{V}, I_D=10\text{A}$	-	29.0	33.0	$\text{m}\Omega$
		$V_{GS}=4.5\text{V}, I_D=5\text{A}$	-	34.0	45.0	$\text{m}\Omega$
<b>Dynamic Characteristics</b>						
$C_{iss}$	Input Capacitance	$V_{GS}=0\text{V}, V_{DS}=25\text{V}, f = 1\text{MHz}$	-	1206	-	pF
$C_{oss}$	Output Capacitance		-	52	-	pF
$C_{rss}$	Reverse Transfer Capacitance		-	42	-	pF
$Q_g$	Total Gate Charge	$V_{GS}=0 \text{ to } 10\text{V}$ $V_{DS}=30\text{V}, I_D=10\text{A}$	-	20.3	-	nC
$Q_{gs}$	Gate Source Charge		-	3.7	-	nC
$Q_{gd}$	Gate Drain ("Miller") Charge		-	5.3	-	nC
<b>Switching Characteristics</b>						
$t_{d(on)}$	Turn-On Delay Time	$V_{GS}=10\text{V}, V_{DD}=30\text{V}$ $I_D=5\text{A}, R_{GEN}=1.8\Omega$	-	6	-	ns
$t_r$	Turn-On Rise Time		-	6	-	ns
$t_{d(off)}$	Turn-Off Delay Time		-	19	-	ns
$t_f$	Turn-Off Fall Time		-	3	-	ns
<b>Drain-Source Diode Characteristics and Max Ratings</b>						
$I_S$	Maximum Continuous Drain to Source Diode Forward Current		-	-	15	A
$I_{SM}$	Maximum Pulsed Drain to Source Diode Forward Current		-	-	60	A
$V_{SD}$	Drain to Source Diode Forward Voltage	$V_{GS}=0\text{V}, I_S=10\text{A}$	-	-	1.2	V
$t_{rr}$	Body Diode Reverse Recovery Time	$I_F=5\text{A}, di/dt=100\text{A}/\mu\text{s}$	-	13	-	ns
$Q_{rr}$	Body Diode Reverse Recovery Charge		-	9	-	nC

Notes:

1. Repetitive Rating: Pulse Width Limited by Maximum Junction Temperature.
2.  $E_{AS}$  condition: Starting  $T_J=25^\circ\text{C}$ ,  $V_{DD}=30\text{V}$ ,  $V_G=10\text{V}$ ,  $R_G=25\Omega$ ,  $L=0.5\text{mH}$ ,  $I_{AS}=10\text{A}$
3. Pulse Test: Pulse Width  $\leq 300\mu\text{s}$ , Duty Cycle  $\leq 0.5\%$ .



## Test Circuit

Figure 1: Gate Charge Test Circuit & Waveform

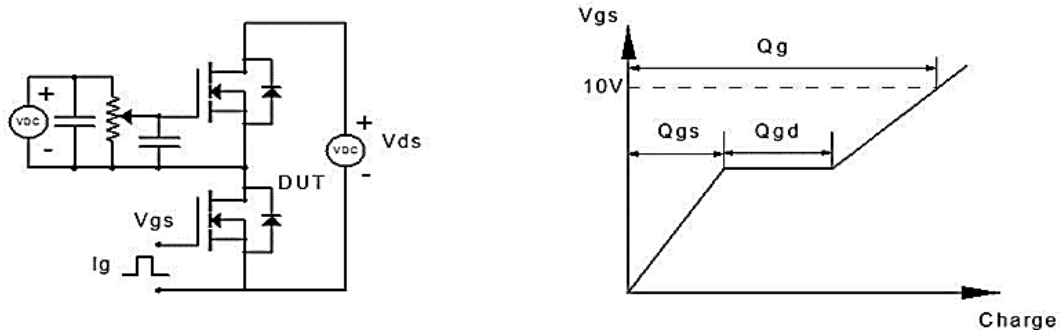

Figure 2: Resistive Switching Test Circuit & Waveform

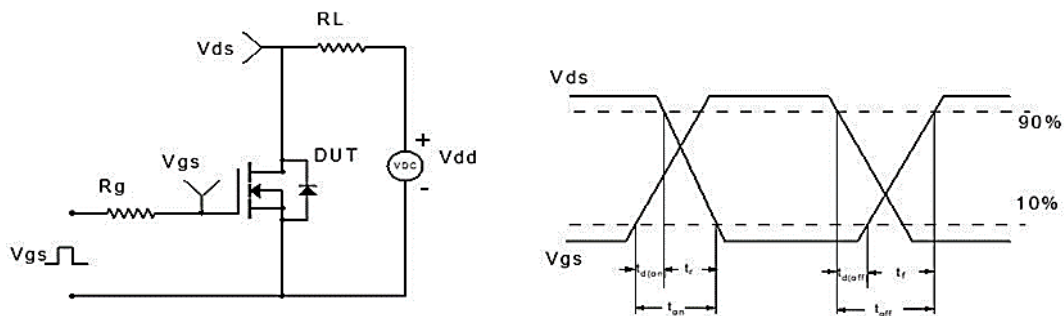

Figure 3: Unclamped Inductive Switching Test Circuit & Waveform

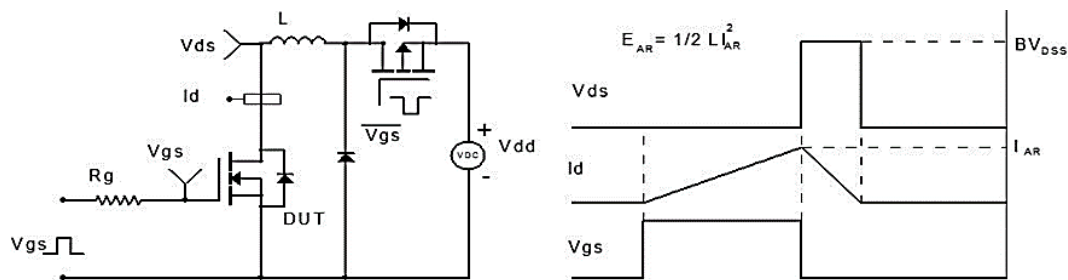
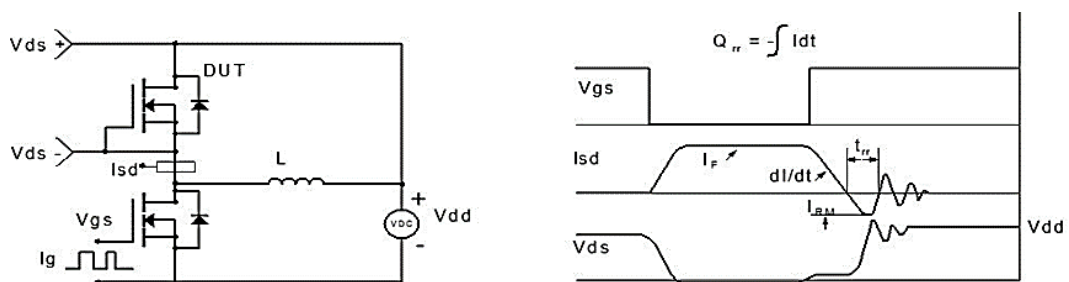
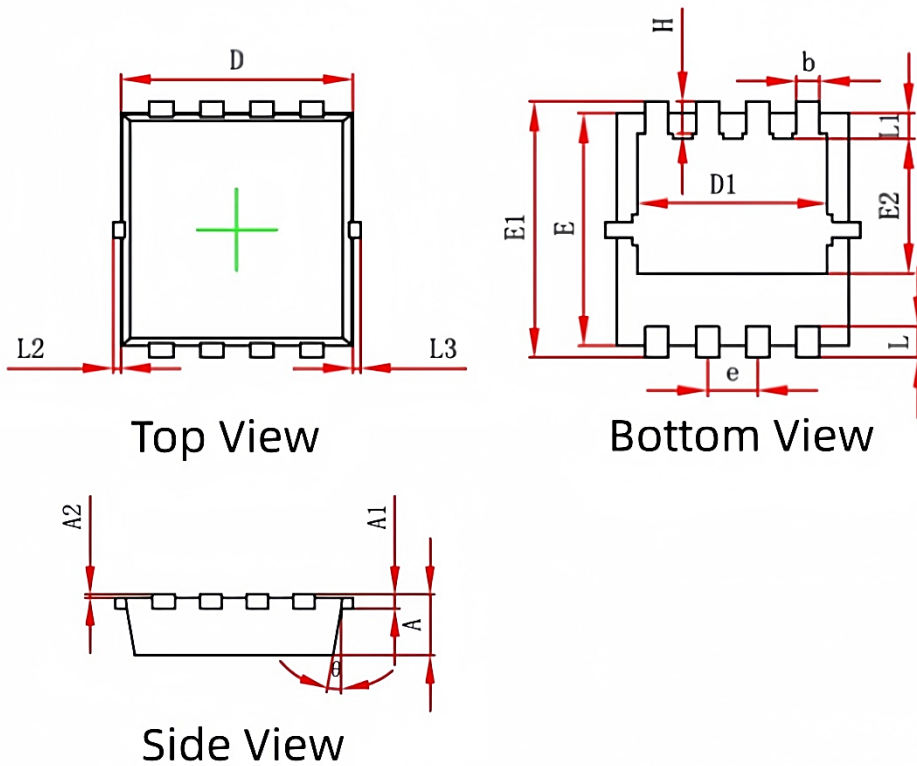

Figure 4: Diode Recovery Test Circuit & Waveform





### Package Mechanical Data(PDFN 3x3-8)



Symbol	Dimensions In Millimeters		Dimensions In Inches	
	Min.	Max.	Min.	Max.
A	0.650	0.850	0.026	0.033
A1	0.152 REF.		0.006 REF.	
A2	0~0.05		0~0.002	
D	2.900	3.100	0.114	0.122
D1	2.300	2.600	0.091	0.102
E	2.900	3.100	0.114	0.122
E1	3.150	3.450	0.124	0.136
E2	1.535	1.935	0.060	0.076
b	0.200	0.400	0.008	0.016
e	0.550	0.750	0.022	0.030
L	0.300	0.500	0.012	0.020
L1	0.180	0.480	0.007	0.019
L2	0~0.100		0~0.004	
L3	0~0.100		0~0.004	
H	0.315	0.515	0.012	0.020
$\theta$	9°	13°	9°	13°

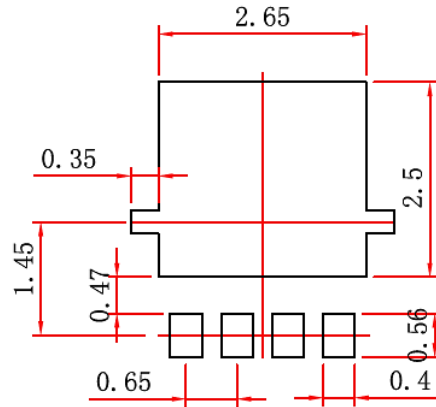

Note:

1. Controlling dimension: in millimeters.
2. General tolerance:  $\pm 0.05\text{mm}$ .
3. The pad layout is for reference purposes only.

## Ordering information

Order Code	Package	$V_{DS}(V)$	$I_D(A)$	$R_{DS(ON)}(m\Omega)$	
				$V_{GS}=10V$	$V_{GS}=4.5V$
QNM30N06AJ	PDFN 3x3-8	60	15	$V_{GS}=10V$	29
				$V_{GS}=4.5V$	34