



QNHCHIP

QNM30NP0812

Product Specification

QNM30NP0812

30V Complementary MOSFET



FEATURES

- N-Channel: 30V, 27A
 $R_{DS(ON)}$ Typ = 7.4m Ω @ $V_{GS} = 10V$
 $R_{DS(ON)}$ Typ = 11.5m Ω @ $V_{GS} = 4.5V$
- P-Channel: -30V, -24A
 $R_{DS(ON)}$ Typ = 11.5m Ω @ $V_{GS} = -10V$
 $R_{DS(ON)}$ Typ = 19.5m Ω @ $V_{GS} = -4.5V$
- Advanced Trench Technology
- Excellent $R_{DS(ON)}$ and Low Gate Charge

Applications

- Battery Protection
- Load Switch
- Power Management

Pin Description

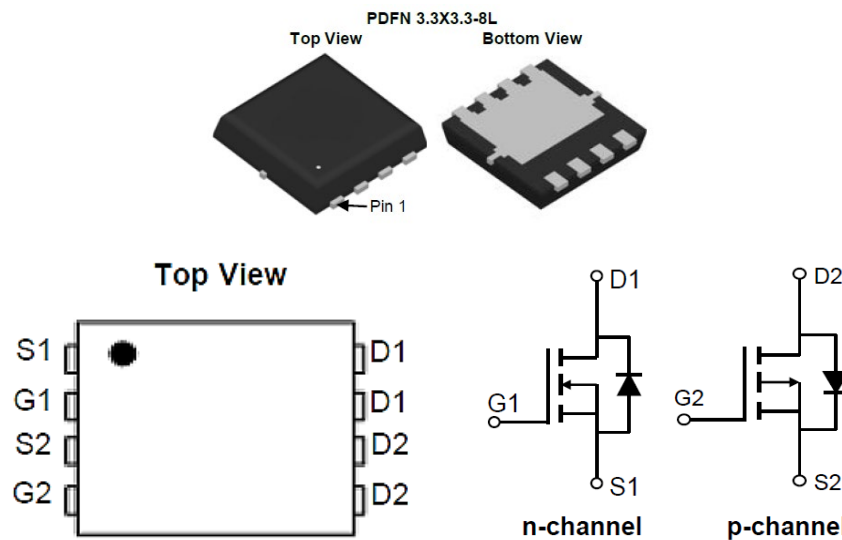

NO.	Symbol	Description
1	S1	SOURCE
2	G1	GATE
3	S2	SOURCE
4	G2	GATE
5	D1	DRAIN
6	D1	DRAIN
7	D2	DRAIN
8	D2	DRAIN



Absolute Maximum Ratings

(@ $T_C = 25^\circ\text{C}$ unless otherwise specified)

Symbol	Parameter	N-Channel Value	P-Channel Value	Units
V_{DS}	Drain-to-Source Voltage	30	-30	V
V_{GS}	Gate-to-Source Voltage	± 20	± 20	V
I_D	Continuous Drain Current	$T_C = 25^\circ\text{C}$	-24	A
		$T_C = 100^\circ\text{C}$	-14.4	
I_{DM}	Pulsed Drain Current ⁽¹⁾	108	-96	A
E_{AS}	Single Pulsed Avalanche Energy ⁽²⁾	30	39	mJ
P_D	Power Dissipation	$T_C = 25^\circ\text{C}$	14.7	W
$R_{\theta JC}$	Thermal Resistance, Junction to Case	8	8.5	$^\circ\text{C}/\text{W}$
T_J, T_{STG}	Junction & Storage Temperature Range	-55 to 150		$^\circ\text{C}$



N-Channel Electrical Characteristics

(T_J = 25°C unless otherwise specified)

Symbol	Parameter	Conditions	Min	Typ	Max	Unit
Off Characteristics						
V _{(BR)DSS}	Drain-Source Breakdown Voltage	I _D = 250uA, V _{GS} = 0V	30	-	-	V
I _{DSS}	Zero Gate Voltage Drain Current	V _{DS} = 30V, V _{GS} = 0V	-	-	1.0	uA
I _{GSS}	Gate-Body Leakage Current	V _{DS} = 0V, V _{GS} = ±20V	-	-	±100	nA
On Characteristics						
V _{GS(th)}	Gate Threshold Voltage	V _{DS} = V _{GS} , I _D = 250uA	1	1.5	2.2	V
R _{DS(ON)}	Static Drain-Source ON-Resistance ⁽³⁾	V _{GS} = 10V, I _D = 20A	-	7.4	9.6	mΩ
		V _{GS} = 4.5V, I _D = 10A	-	11.5	15	mΩ ②
Dynamic Characteristics						
C _{iss}	Input Capacitance	V _{GS} = 0V, V _{DS} = 15V, f = 1MHz	-	1004	-	pF
C _{oss}	Output Capacitance		-	117	-	pF
C _{rss}	Reverse Transfer Capacitance		-	88	-	pF
Q _g	Total Gate Charge	V _{GS} = 0 to 10V V _{DS} = 15V, I _D = 20A	-	20	-	nC
Q _{gs}	Gate Source Charge		-	4	-	nC
Q _{gd}	Gate Drain ("Miller") Charge		-	5	-	nC
Switching Characteristics						
t _{d(on)}	Turn-On DelayTime	V _{GS} = 10V, V _{DD} = 15V I _D = 20A, R _{GEN} = 3Ω	-	6	-	ns
t _r	Turn-On Rise Time		-	19	-	ns
t _{d(off)}	Turn-Off DelayTime		-	22	-	ns
t _f	Turn-Off Fall Time		-	5	-	ns
Drain-Source Diode Characteristics and Max Ratings						
I _S	Maximum Continuous Drain to Source Diode Forward Current		-	-	27	A
I _{SM}	Maximum Pulsed Drain to Source Diode Forward Current		-	-	108	A
V _{SD}	Drain to Source Diode Forward Voltage	V _{GS} = 0V, I _S = 20A	-	-	1.2	V
t _{rr}	Body Diode Reverse Recovery Time	I _F = 20A, di/dt = 100A/us	-	8	-	ns
Q _{rr}	Body Diode Reverse Recovery Charge		-	1.6	-	nC

Notes: 1. Repetitive Rating: Pulse Width Limited by Maximum Junction Temperature.

2. E_{AS} condition: Starting T_J=25°C, V_{DD}=15V, V_G=10V, R_G=25ohm, L=0.5mH, I_{AS}=11A

3. Pulse Test: Pulse Width ≤ 300us, Duty Cycle ≤ 0.5%.



P-Channel Electrical Characteristics

(T_J = 25°C unless otherwise specified)

Symbol	Parameter	Test Condition	Min.	Typ.	Max.	Units
Off Characteristic						
V _{(BR)DSS}	Drain-Source Breakdown Voltage	V _{GS} =0V, I _D = -250μA	-30	-	-	V
I _{DSS}	Zero Gate Voltage Drain Current	V _{DS} = -30V, V _{GS} =0V,	-	-	-1	μA
I _{GSS}	Gate to Body Leakage Current	V _{DS} =0V, V _{GS} = ±20V	-	-	±100	nA
On Characteristics						
V _{GS(th)}	Gate Threshold Voltage	V _{DS} =V _{GS} , I _D = -250μA	-1.0	-1.6	-2.5	V
R _{DS(on)}	Static Drain-Source on-Resistance ³	V _{GS} = -10V, I _D = -10A	-	11.5	15	mΩ
		V _{GS} = -4.5V, I _D = -8A	-	19.5	25.5	
Dynamic Characteristics						
C _{iss}	Input Capacitance	V _{GS} = 0V, V _{DS} = -15V, f = 1MHz	-	900	-	pF
C _{oss}	Output Capacitance		-	172	-	pF
C _{rss}	Reverse Transfer Capacitance		-	146	-	pF
Q _g	Total Gate Charge	V _{GS} = 0 to -10V V _{DS} = -15V, I _D = -5A	-	22	-	nC
Q _{gs}	Gate-Source Charge		-	3	-	nC
Q _{gd}	Gate-Drain("Miller") Charge		-	6	-	nC
Switching Characteristics						
t _{d(on)}	Turn-on Delay Time	V _{GS} = -10V, V _{DD} = -15V I _D = -5A, R _{GEN} = 2.5 Ω	-	10	-	ns
t _r	Turn-on Rise Time		-	14	-	ns
t _{d(off)}	Turn-off Delay Time		-	50	-	ns
t _f	Turn-off Fall Time		-	20	-	ns
Drain-Source Diode Characteristics and Maximum Ratings						
I _S	Maximum Continuous Drain to Source Diode Forward Current		-	-	-24	A
I _{SM}	Maximum Pulsed Drain to Source Diode Forward Current		-	-	-96	A
V _{SD}	Drain to Source Diode Forward Voltage	V _{GS} =0V, I _S = -10A	-	-	-1.2	V
t _{rr}	Reverse Recovery Time	I _F = -5A, di/dt = 100A/us	-	64	-	ns
Q _{rr}	Reverse Recovery Charge		-	25	-	nC

Notes: 1. Repetitive Rating: Pulse Width Limited by Maximum Junction Temperature.

2. E_{AS} condition: Starting T_J=25°C, V_{DD}=-15V, V_G=-10V, R_G=25ohm, L=0.5mH, I_{AS}=-12.5A

3. Pulse Test: Pulse Width ≤ 300us, Duty Cycle ≤ 0.5%.



Test Circuit N-MOS

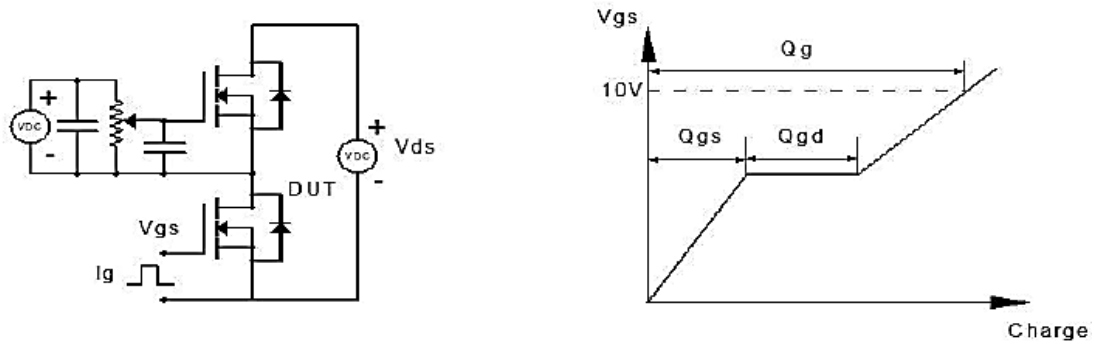

Figure 1: Gate Charge Test Circuit & Waveform

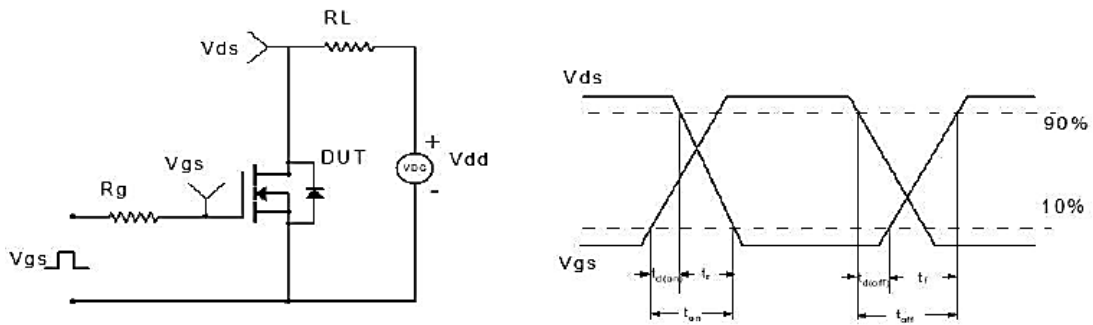

Figure 2: Resistive Switching Test Circuit & Waveform

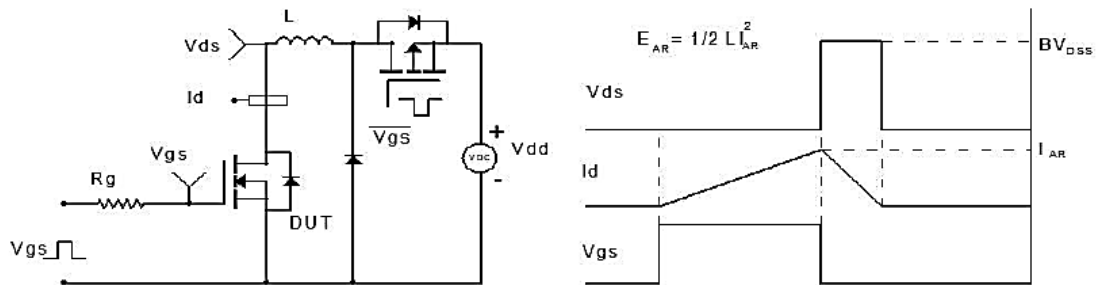

Figure 3: Unclamped Inductive Switching Test Circuit & Waveform

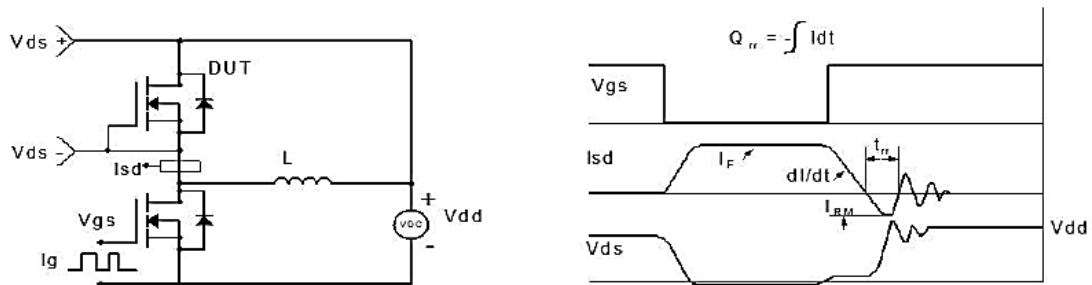

Figure 4: Diode Recovery Test Circuit & Waveform



Test Circuit P-MOS

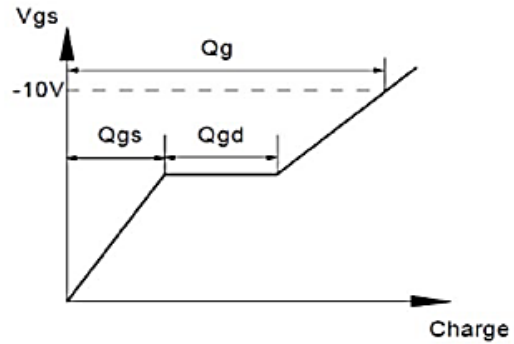
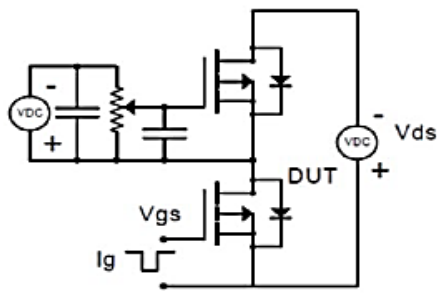

Figure 1: Gate Charge Test Circuit & Waveform

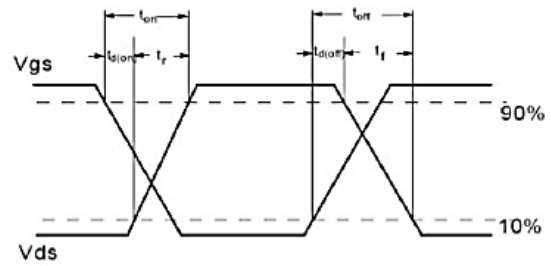
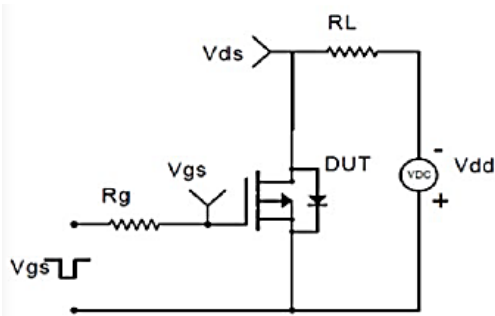

Figure 2: Resistive Switching Test Circuit & Waveform

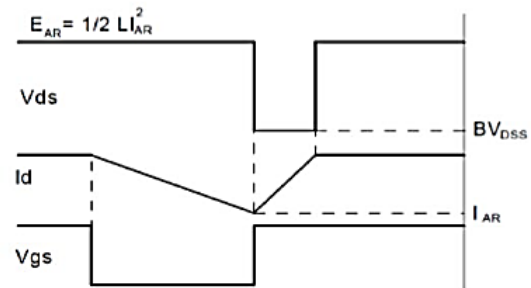
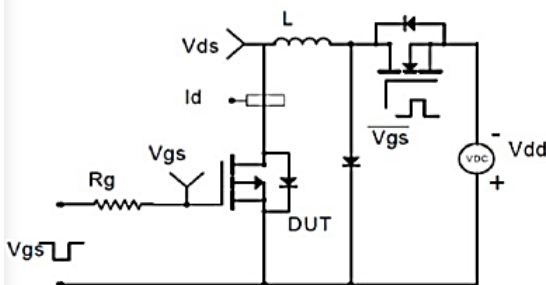

Figure 3: Unclamped Inductive Switching Test Circuit & Waveform

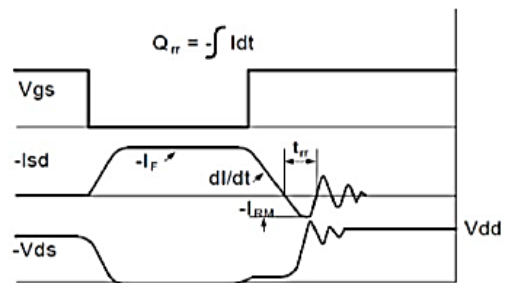
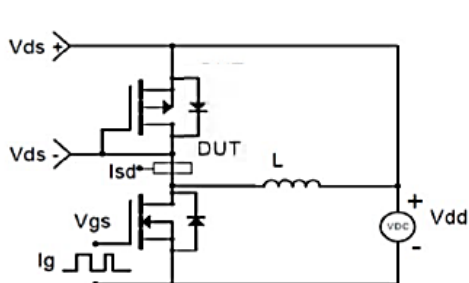
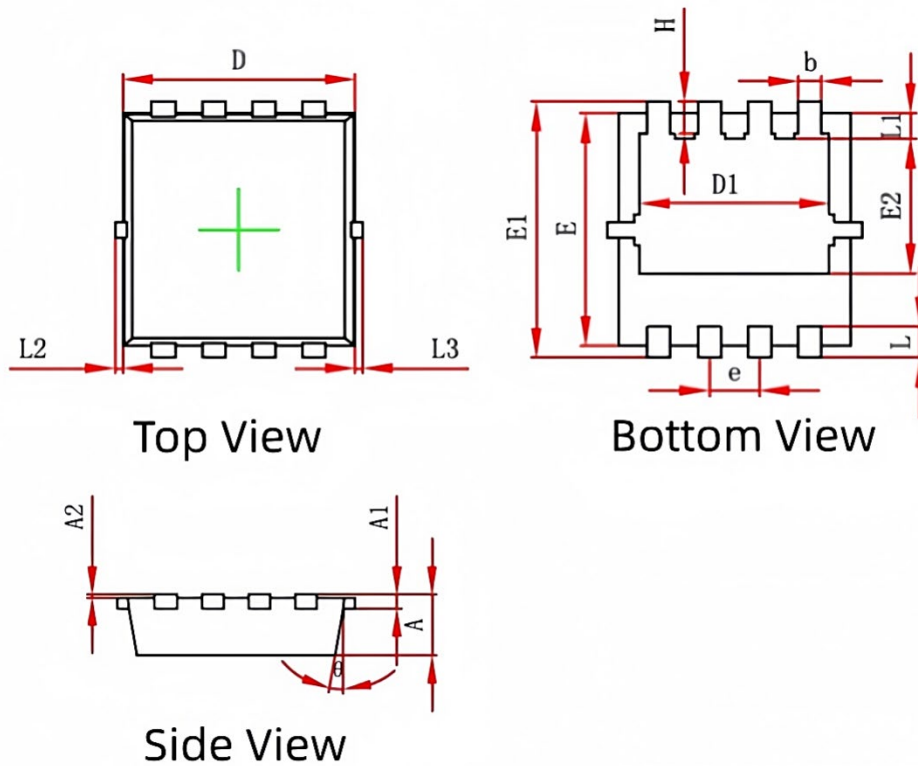

Figure 4: Diode Recovery Test Circuit & Waveform



Package Mechanical Data(PDFN 3.3x3.3-8)



Symbol	Dimensions In Millimeters		Dimensions In Inches	
	Min.	Max.	Min.	Max.
A	0.650	0.850	0.026	0.033
A1	0.152 REF.		0.006 REF.	
A2	0~0.05		0~0.002	
D	2.900	3.100	0.114	0.122
D1	2.300	2.600	0.091	0.102
E	2.900	3.100	0.114	0.122
E1	3.150	3.450	0.124	0.136
E2	1.535	1.935	0.060	0.076
b	0.200	0.400	0.008	0.016
e	0.550	0.750	0.022	0.030
L	0.300	0.500	0.012	0.020
L1	0.180	0.480	0.007	0.019
L2	0~0.100		0~0.004	
L3	0~0.100		0~0.004	
H	0.315	0.515	0.012	0.020
θ	9°	13°	9°	13°

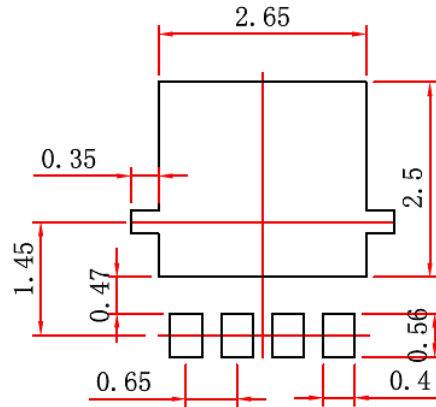

Note:

1. Controlling dimension: in millimeters.
2. General tolerance: $\pm 0.05\text{mm}$.
3. The pad layout is for reference purposes only.

Ordering information

Order Code	Package	$V_{DS}(V)$	$I_D(A)$	$R_{DS(ON)}(m\Omega)$	
				$V_{GS}=10V$	$V_{GS}=4.5V$
QNM30NP0812	PDFN 3.3x3.3-8	30	27	$V_{GS}=10V$	7.4
				$V_{GS}=4.5V$	11.5
		-30	-24	$V_{GS}=-10V$	11.5
				$V_{GS}=-4.5V$	19.5