

# BCT65N45M1

## N-Channel Silicon Carbide Power MOSFET

650 V, 44 A, 45 mΩ



bestirpower

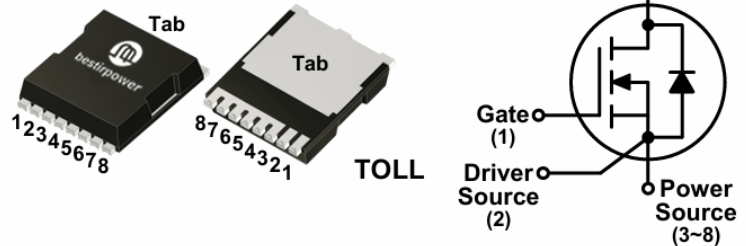
### Features

- High switching speed with a low gate charge
- Fast intrinsic diode with low reverse recovery
- Robust Avalanche Capability
- 100% Avalanche Tested
- Halogen Free, and RoHS Compliant

$BV_{DSS, T_C=25^\circ C}$	$I_D, T_C=25^\circ C$	$R_{DS(on), typ}$	$Q_{g, typ}$
650 V	44 A	45 mΩ	55 nC

### Benefits

- System efficiency improvement
- Higher frequency applicability
- Increased power density
- Reduced cooling effort



### Applications

- Solar inverter / ESS / UPS
- EV charging station
- Server & Telecom power
- Industrial power supply



### Absolute Maximum Ratings ( $T_J = 25^\circ C$ unless otherwise noted)

Symbol	Parameter	Value	Unit
$V_{DSS}$	Drain to Source Voltage	650	V
$V_{GS}$	Gate to Source Voltage (DC)	-10 / +22	V
$V_{GSop}$	Recommended Operation Value	-5 / +18	V
$I_D$	Drain Current	$V_{GS} = 18 V, (T_C = 25^\circ C)$	44
		$V_{GS} = 18 V, (T_C = 100^\circ C)$	31
$I_{DM}$	Drain Current	Pulsed (Note1)	117
$P_D$	Power Dissipation	$(T_C = 25^\circ C)$	150
		Derate Above 25°C	1.0
$T_J, T_{STG}$	Operating and Storage Temperature Range	-55 to 175	°C
$T_L$	Maximum Lead Temperature for Soldering, 1/8" from Case for 10 Seconds	260	°C

※Note 1 : Limited by maximum junction temperature.

### Thermal Characteristics

Symbol	Parameter	Value	Unit
$R_{\theta JC}$	Thermal Resistance, Junction to Case, Max.	1.0	°C/W
$R_{\theta JA}$	Thermal Resistance, Junction to Ambient, Max.	40	
$T_{sold}$	Soldering temperature, wave soldering only allowed at leads	260	°C

**Electrical Characteristics** ( $T_J = 25^\circ\text{C}$  unless otherwise noted)

Symbol	Parameter	Test Conditions	Min	Typ	Max	Unit
<b>Off Characteristics</b>						
$BV_{DSS}$	Drain to Source Breakdown Voltage	$V_{GS} = 0\text{ V}, I_D = 1\text{ mA}$	650	-	-	V
$I_{DSS}$	Zero Gate Voltage Drain Current	$V_{DS} = 650\text{ V}, V_{GS} = 0\text{ V}$	-	1	100	$\mu\text{A}$
		$V_{DS} = 650\text{ V}, V_{GS} = 0\text{ V}, T_J = 175^\circ\text{C}$	-	10	-	
$I_{GSS}$	Gate-Source Leakage Current	$V_{GS} = +22\text{ V}, V_{DS} = 0\text{ V}$	-	-	+100	$\text{nA}$
		$V_{GS} = -10\text{ V}, V_{DS} = 0\text{ V}$	-	-	-100	

**On Characteristics**

$V_{GS(th)}$	Gate Threshold Voltage	$V_{GS} = V_{DS}, I_D = 7\text{ mA}$	1.8	2.8	4.5	V
$R_{DS(on)}$	Static Drain to Source On Resistance	$V_{GS} = 18\text{ V}, I_D = 20\text{ A}$	-	45	63	$\text{m}\Omega$
		$V_{GS} = 18\text{ V}, I_D = 20\text{ A}, T_J = 175^\circ\text{C}$	-	59	-	
$g_{fs}$	Transconductance	$V_{DS} = 20\text{ V}, I_D = 20\text{ A}$	-	13.4	-	S

**Dynamic Characteristics**

$C_{iss}$	Input Capacitance	$V_{DS} = 400\text{ V}, V_{GS} = 0\text{ V}, f = 1\text{ MHz}$	-	1048	-	$\text{pF}$
$C_{oss}$	Output Capacitance		-	131	-	
$C_{rss}$	Reverse Capacitance		-	9.1	-	
$E_{oss}$	Stored Energy in Output Capacitance	$V_{DS} = 0\text{ V to } 400\text{ V}, V_{GS} = 0\text{ V}$	-	13.0	-	$\mu\text{J}$
$C_{o(er)}$	Energy Related Output Capacitance		-	162.0	-	$\text{pF}$
$C_{o(tr)}$	Time Related Output Capacitance		-	236	-	
$Q_{g(tot)}$	Total Gate Charge	$V_{DS} = 400\text{ V}, I_D = 20\text{ A},$ $V_{GS} = -5\text{ V} / 18\text{ V},$ Inductive load	-	56	-	$\text{nC}$
$Q_{gs}$	Gate to Source Charge		-	14	-	
$Q_{gd}$	Gate to Drain "Miller" Charge		-	15	-	
$R_G$	Internal Gate Resistance	$f = 1\text{ MHz}, V_{AC} = 30\text{ mV}$ open drain	-	4.0	-	$\Omega$

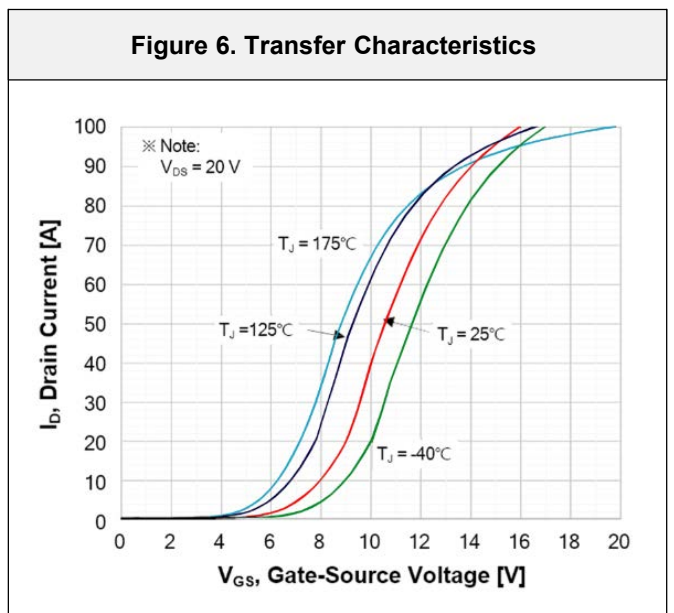
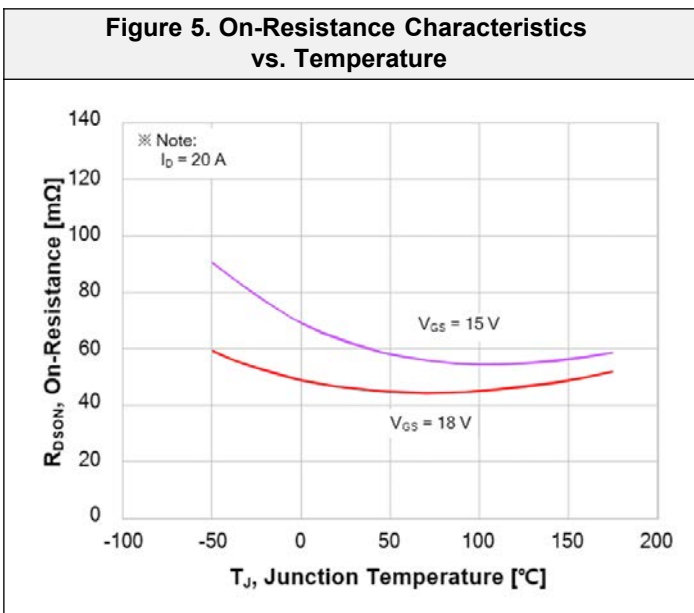
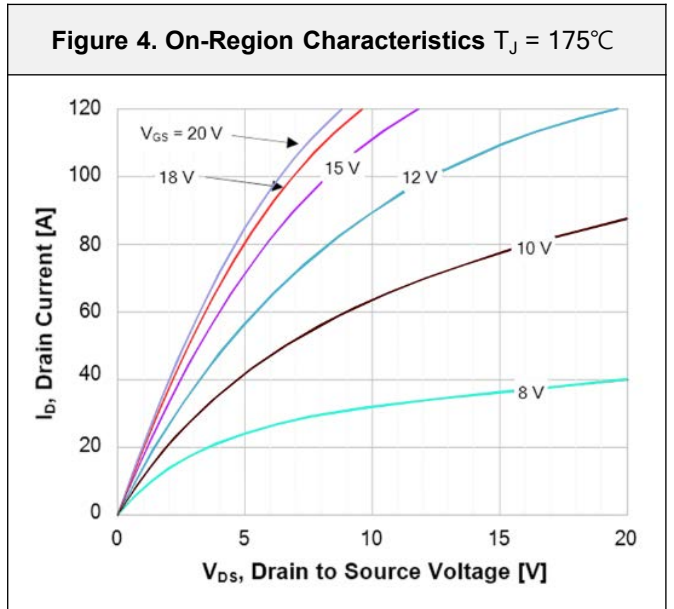
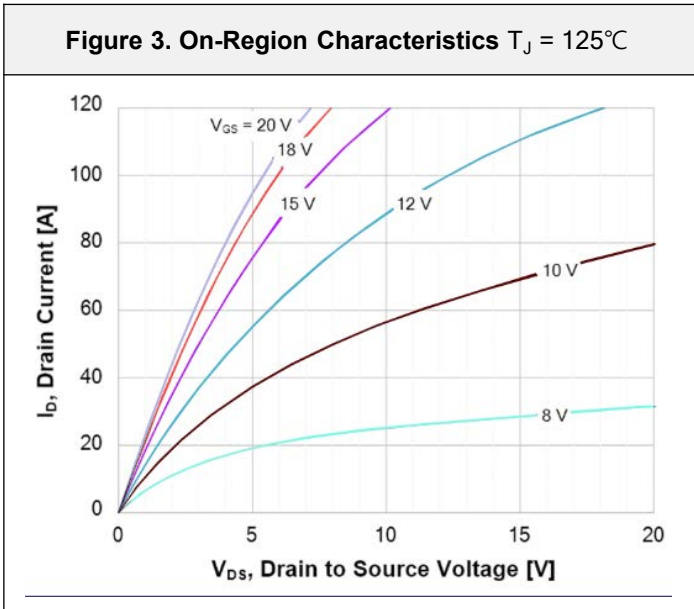
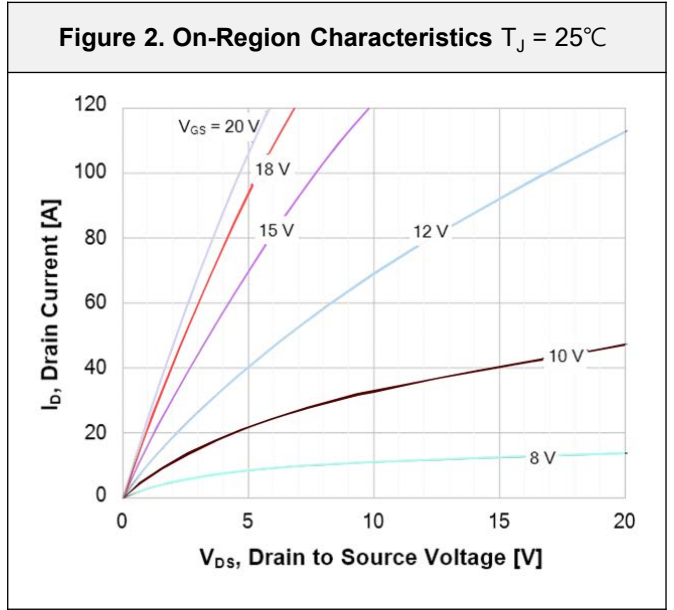
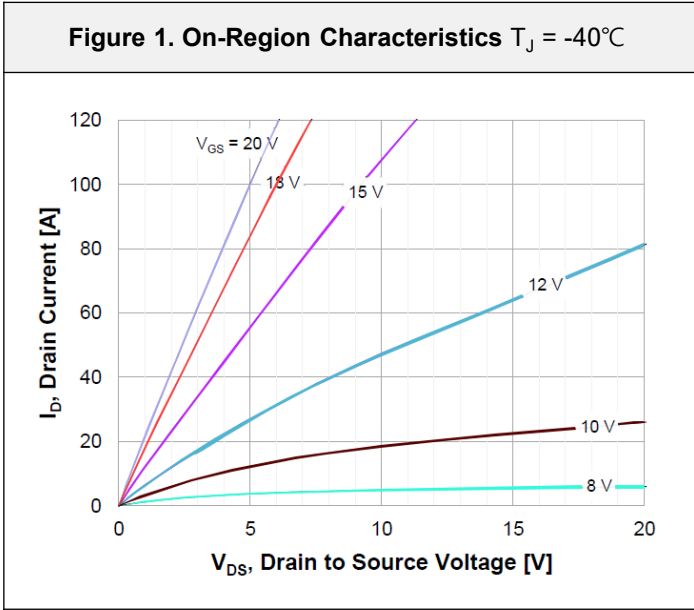
**Switching Characteristics**

$t_{d(on)}$	Turn-On Delay Time	$V_{DS} = 400\text{ V}, I_D = 20\text{ A},$ $V_{GS} = -5\text{ V} / 18\text{ V}, R_G = 2\ \Omega,$ FWD : BCH65S012D1, Inductive load	-	13	-	ns
$t_r$	Turn-On Rise Time		-	10	-	
$t_{d(off)}$	Turn-Off Delay Time		-	26	-	
$t_f$	Turn-Off Fall Time		-	5	-	
$E_{on}$	Turn-on Switching Energy		-	27	-	$\mu\text{J}$
$E_{off}$	Turn-off Switching Energy		-	18	-	
$E_{tot}$	Total Switching Energy		-	45	-	

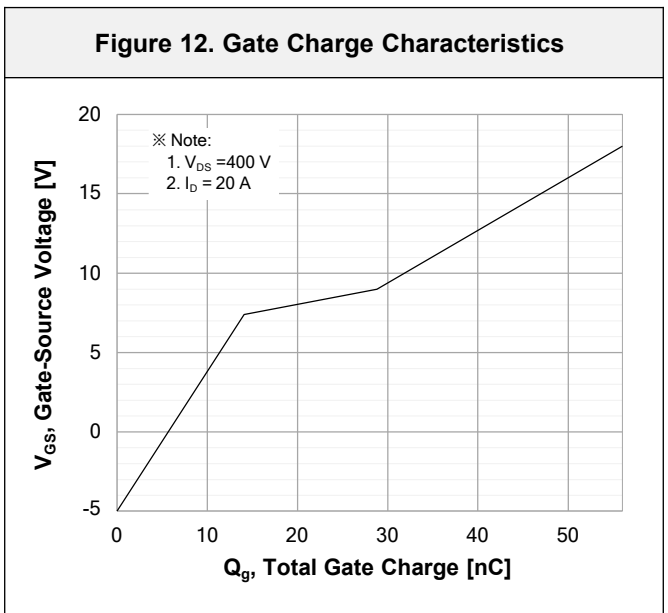
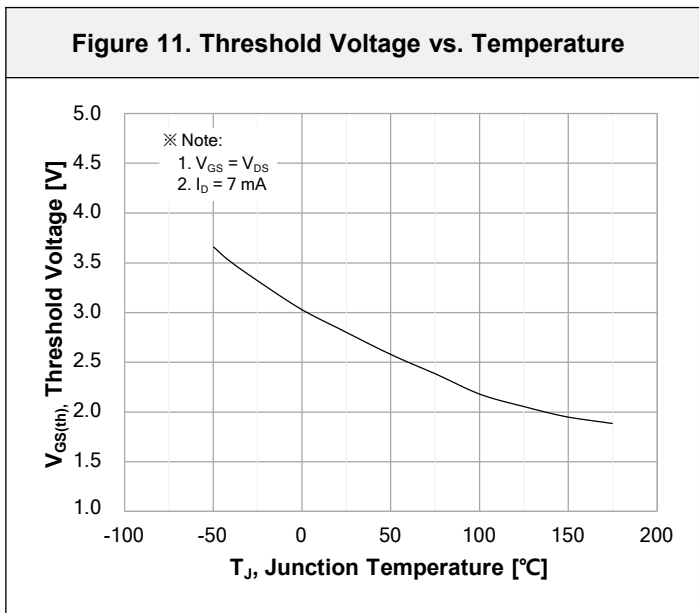
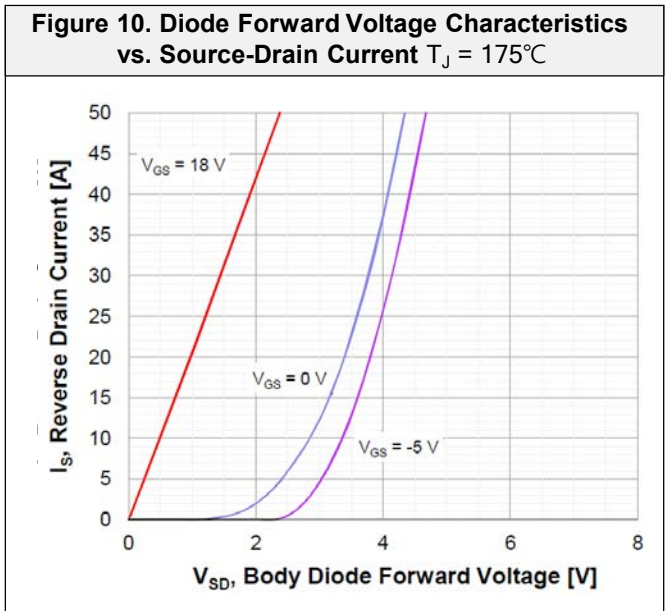
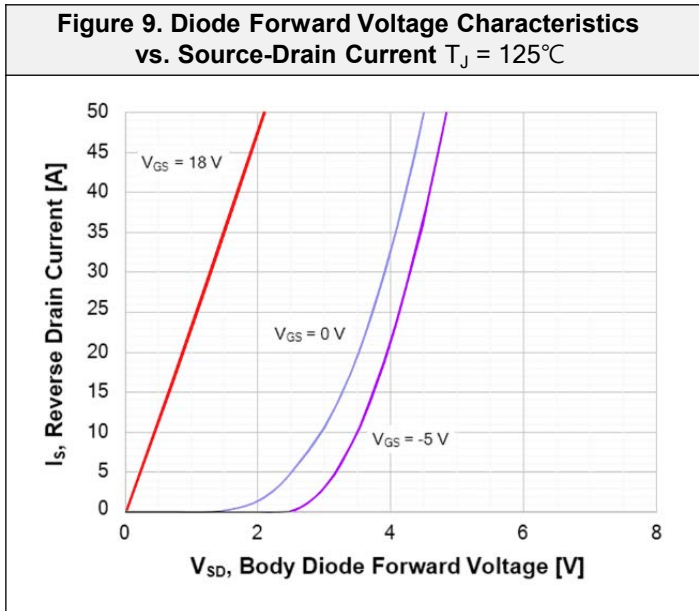
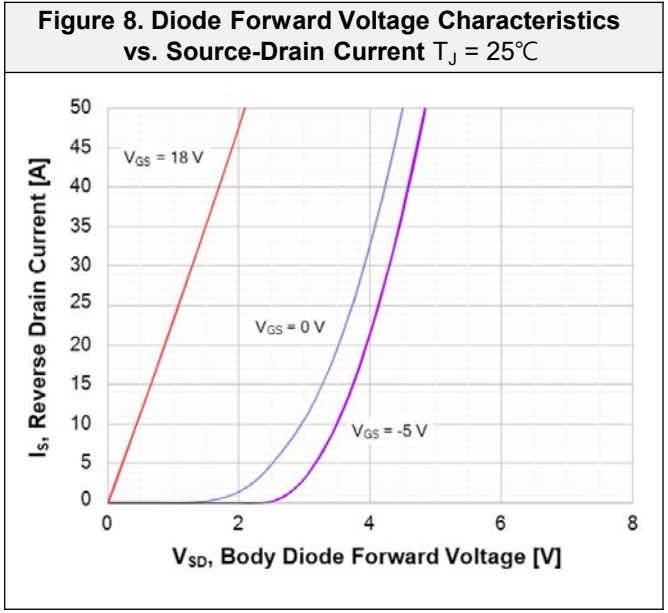
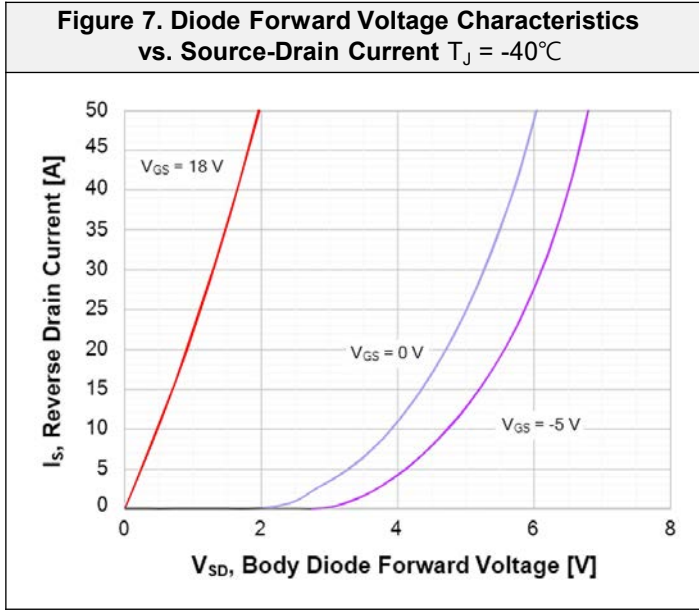
**Source-Drain Diode Characteristics**

$I_S$	Maximum Continuous Diode Forward Current	-	-	42	A	
$I_{SM}$	Maximum Pulsed Diode Forward Current	-	-	117		
$V_{SD}$	Diode Forward Voltage	$V_{GS} = -5\text{ V}, I_{SD} = 20\text{ A}$	-	4.2	-	V
$t_{rr}$	Reverse Recovery Time	$V_{DD} = 400\text{ V}, I_{SD} = 20\text{ A},$ $di_f/dt = 1000\text{ A}/\mu\text{s}$ , Includes $Q_{OSS}$	-	17	-	ns
$Q_{rr}$	Reverse Recovery Charge		-	104	-	nC
$I_{rrm}$	Peak Reverse Recovery Current		-	10	-	A

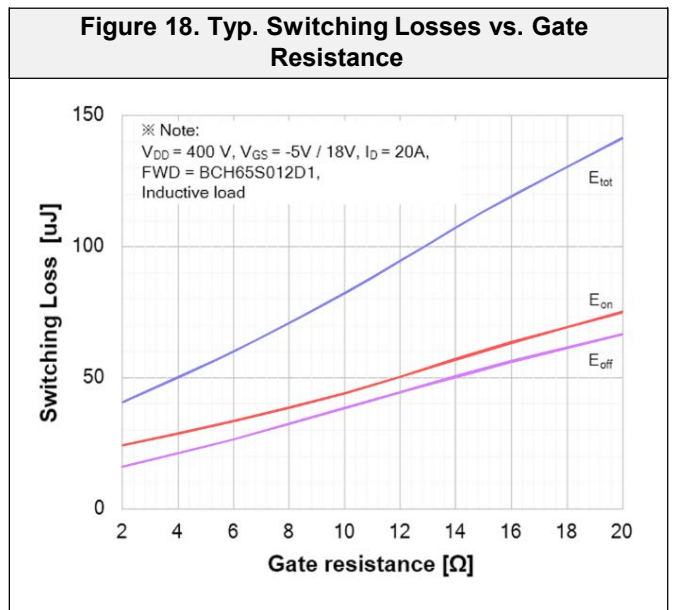
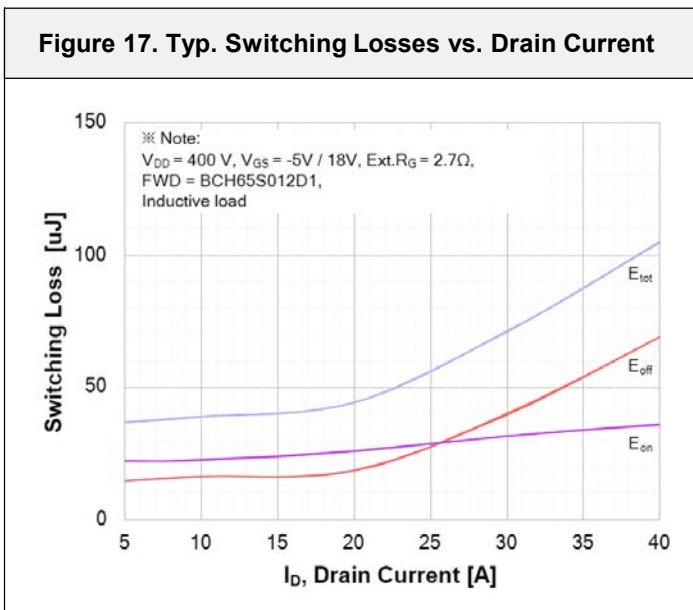
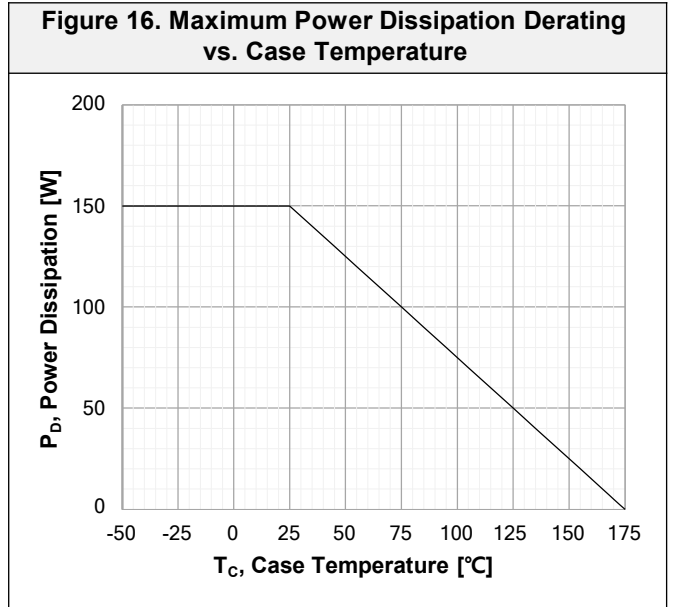
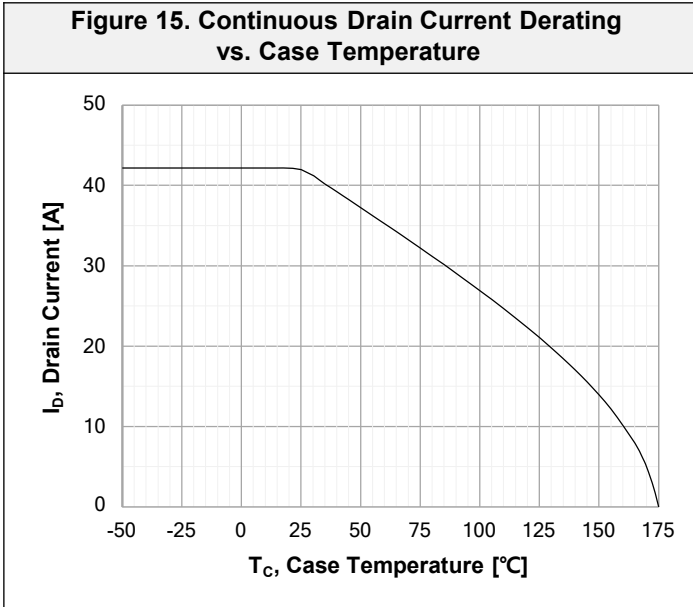
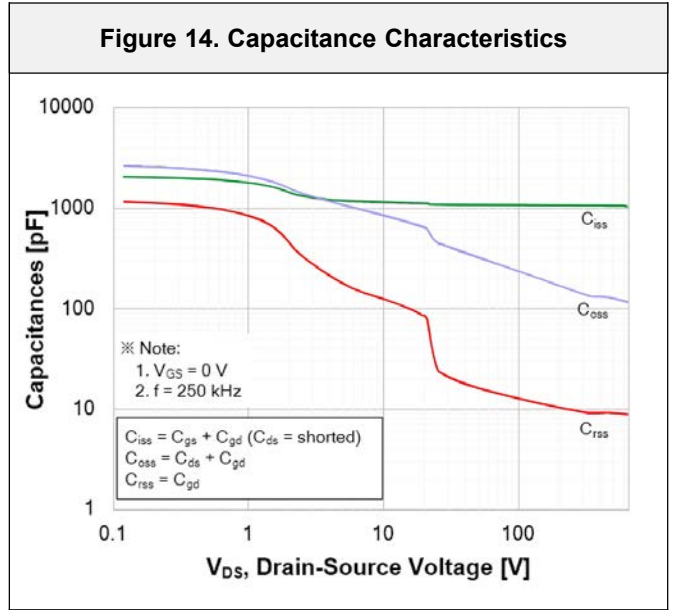
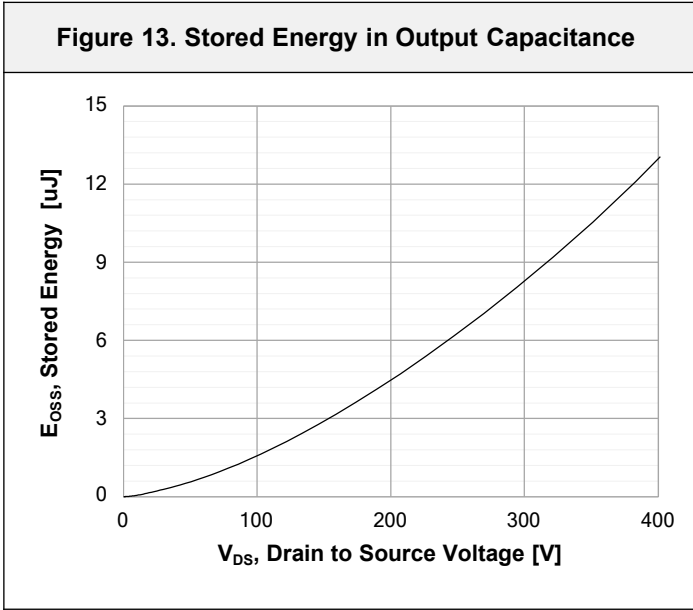
### Typical Performance Characteristics



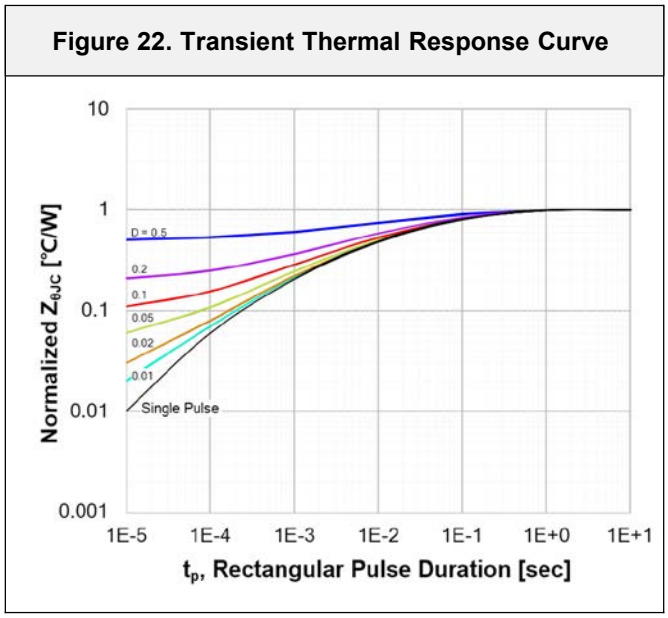
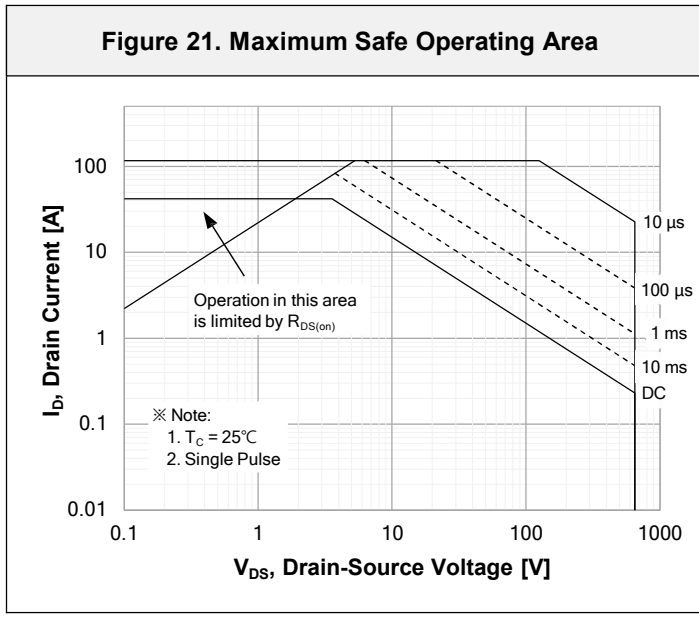
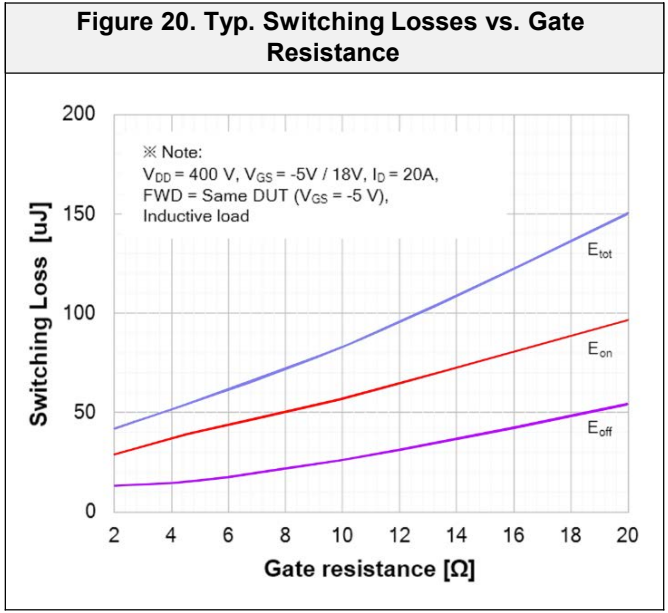
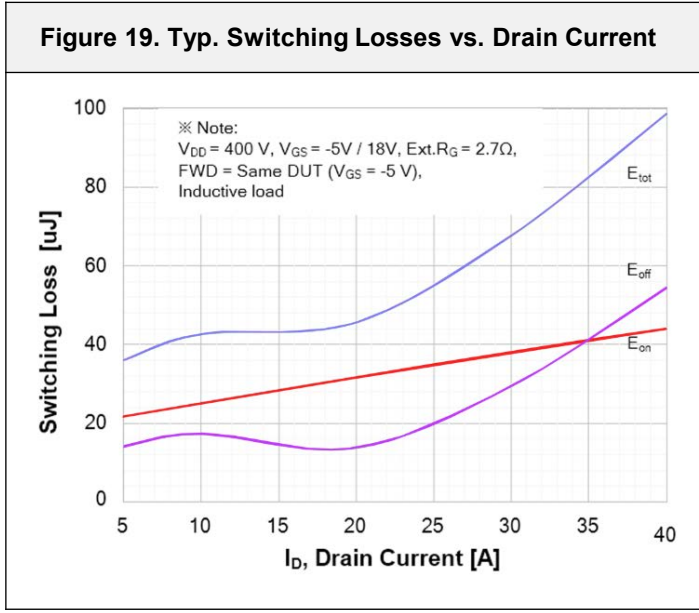
### Typical Performance Characteristics



### Typical Performance Characteristics

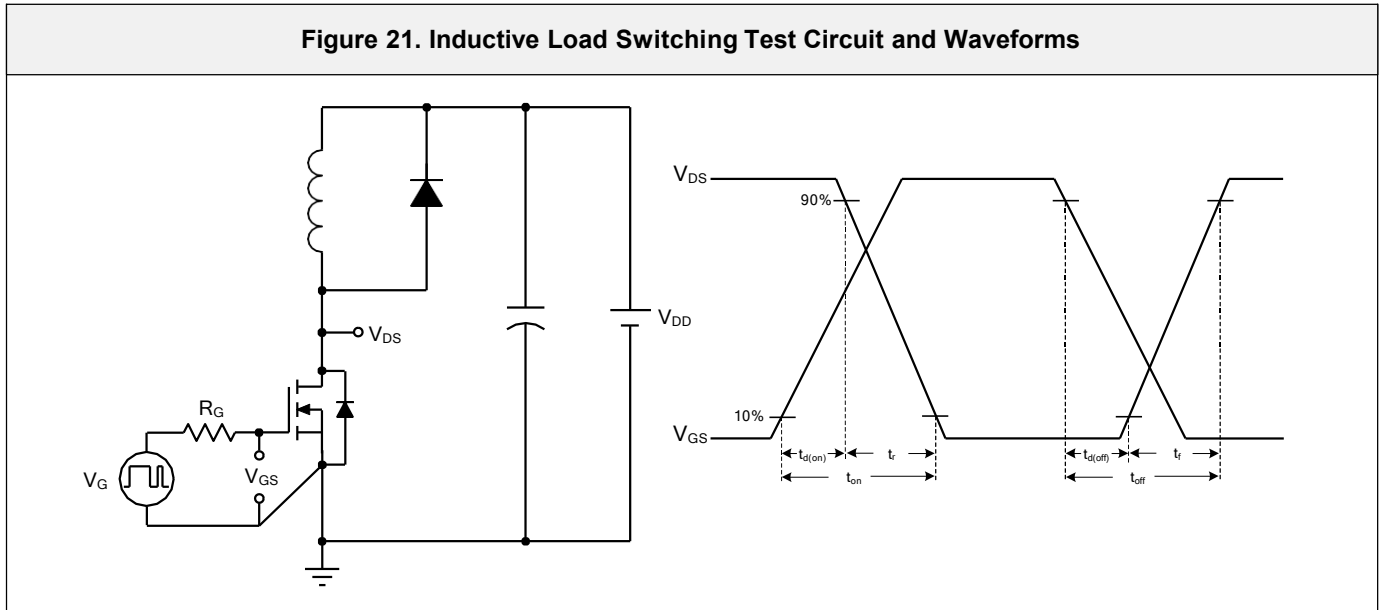


### Typical Performance Characteristics

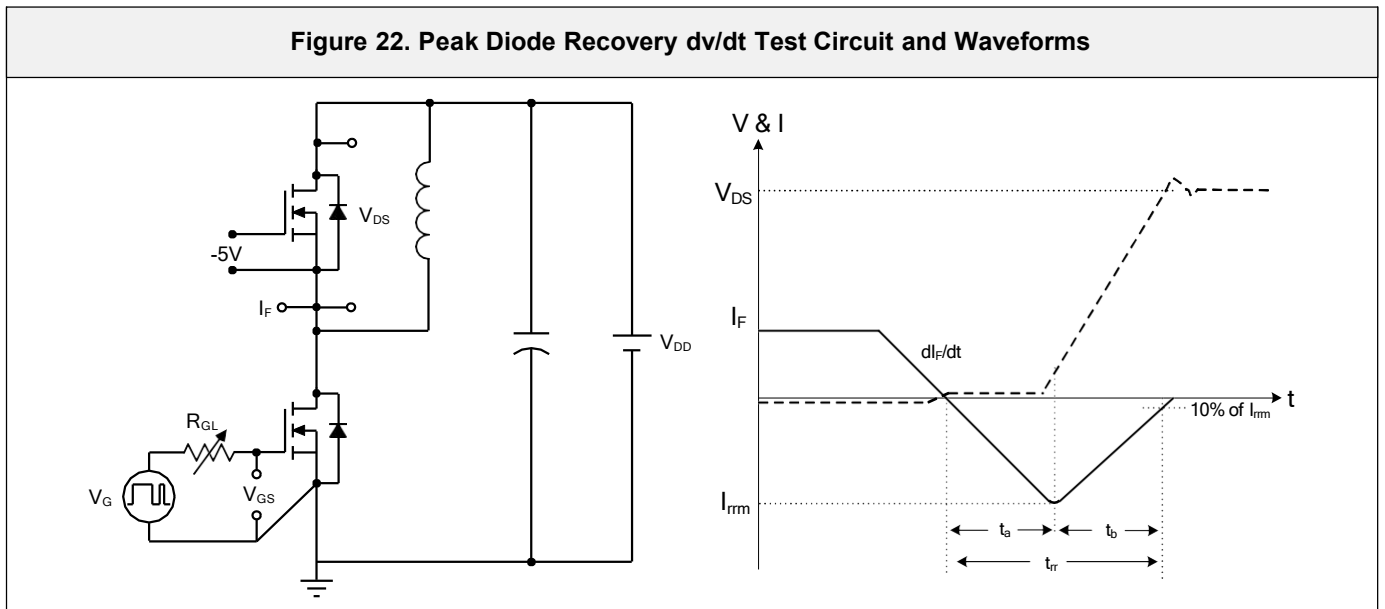


## Typical Performance Characteristics

**Figure 21. Inductive Load Switching Test Circuit and Waveforms**

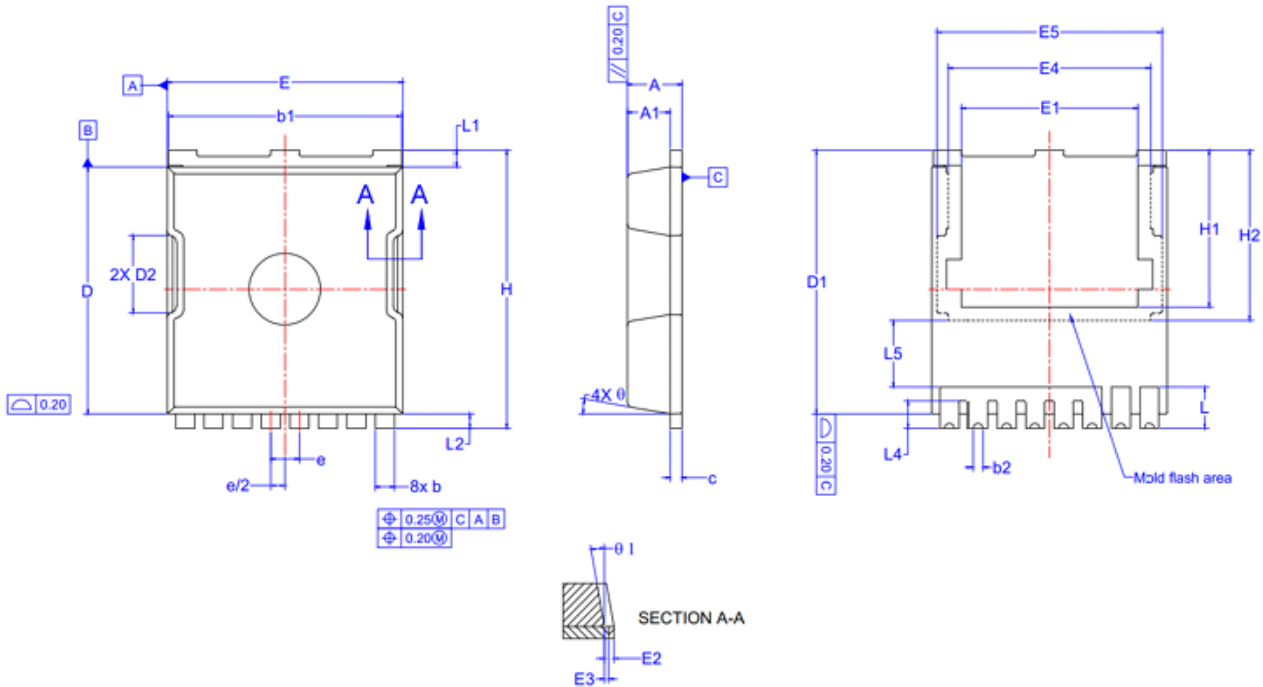


**Figure 22. Peak Diode Recovery  $dv/dt$  Test Circuit and Waveforms**



**Package Outlines**

**TOLL**



SYMBOL	MIN.	NOM.	MAX.
A	2.20	2.30	2.40
A1	1.70	1.80	1.90
b	0.70	0.80	0.90
b1	9.70	9.80	9.90
b2	0.36	0.41	0.51
c	0.40	0.50	0.60
D	10.28	10.38	10.48
D1	10.98	11.08	11.18
D2	3.30		
E	9.80	9.90	10.00
E1	7.32	7.42	7.52
E2	0.30	0.40	0.50
E3	0.15	0.18	0.21
E4	8.50		
E5	9.46		
e	1.20 BASIC		
H	11.58	11.68	11.78
H1	6.55	6.65	6.75
H2	7.05	7.15	7.25
L	1.63	1.73	1.83
L1	0.60	0.70	0.80
L2	0.50	0.60	0.70
L4	1.00	1.15	1.30
L5	2.70	2.80	2.90
N	8		
θ	10° REF.		
θ1	10° REF.		

\* Dimensions in millimeters

## Package Marking and Ordering Information

Part Number	Top Marking	Package	Packing Method	Quantity
BCT65N45M1	BCT65N45M1	TOLL	Tape & Reel	1200 units

## Disclaimer

Bestirpower reserve the right to make changes, corrections, enhancements, modifications, and improvements to Bestirpower products and/or to this document at any time without notice.

The information given in this document shall in no event be regarded as a guarantee of conditions or characteristics. Bestirpower does not assume any liability for infringement of patents, copyrights, or other intellectual property rights of third parties by or arising from the use of Products or technical information described in this document.

This document is the property of Bestirpower Co., LTD., and not allowed to copy or transformed to other format if not under the authority approval.

© 2024 bestirpower – All rights reserved