

Multi SMD LED RGB



LINKS TO ADDITIONAL RESOURCES



DESCRIPTION

The VLMRGB6122... is a high brightness tricolor LED designed primarily for RGB displays and ambient lighting. It is using the popular 6 pin PLCC6 SMD package with 120° emission characteristic. The 6 pin package with separate anodes and cathodes per color allows individual driving of each chip also in serial circuits and thus a gapless coverage of a wide color space by additive color mixing. It provides high reliability in a temperature range from -40 °C to +110 °C, using highly suitable blue light stable package materials.

PRODUCT GROUP AND PACKAGE DATA

- Product group: LED
- Package: SMD PLCC-6
- Product series: RGB
- Angle of half intensity: $\pm 60^\circ$

FEATURES

- Utilizing high brightness AlInGaP and InGaN chip technologies
- 6 pin RGB SMD LED package allows individual control of the driving current of each chip
- Compact package outline dimensions (L x W x H in mm): 3.5 x 2.8 x 1.4
- AEC-Q102 qualified
- Corrosion robustness class: B1
- Qualified according to JEDEC® moisture sensitivity level 3
- Compatible to IR reflow soldering
- Operation temperature range: -40 °C to +110 °C
- ESD-withstand voltage: up to 2 kV for red and 8 kV for blue and green according to JESD22-A114-B
- Luminous intensity, color and forward voltage categorized per reel
- Material categorization: for definitions of compliance please see www.vishay.com/doc?99912

APPLICATIONS

- Automotive interior lighting
- Ambient lighting
- Switch illumination
- Telecommunication, office equipment, home appliances, industrial equipment, white goods
- Wide range of accent and decorative lighting
- Displays: full color message and displays video boards
- Status indicator
- Signal and symbol illumination



PARTS TABLE														
PART	COLOR	LUMINOUS INTENSITY (mcd)			at I _F (mA)	DOMINANT WAVELENGTH (nm)			at I _F (mA)	FORWARD VOLTAGE (V)			at I _F (mA)	TECHNOLOGY
		MIN.	TYP.	MAX.		MIN.	TYP.	MAX.		MIN.	TYP.	MAX.		
VLMRGB6122-B00-08	Red	710	900	1400	20	618	623	630	20	1.75	1.95	2.75	20	AllInGaP
	Green	1800	2200	2800	20	520	527	535	20	2.5	2.75	3.5	20	InGaN
	Blue	280	320	450	20	450	455	462	20	2.5	3.0	3.5	20	InGaN

Note

- Measurement accuracy: $\pm 8\%$ for luminous intensity, ± 1 nm for dominant wavelength, ± 0.05 V for forward voltage



ABSOLUTE MAXIMUM RATINGS ($T_{amb} = 25\text{ }^{\circ}\text{C}$, unless otherwise specified) VLMRGB6122.., RED, GREEN, BLUE						
PARAMETER	TEST CONDITION	SYMBOL	VALUE			UNIT
			RED	GREEN	BLUE	
Forward current		I_F	50	30	30	mA
Reverse voltage		V_R	Not designed for reverse operation			V
Power dissipation		P_{tot}	137	105	105	mW
Junction temperature		T_j	125			$^{\circ}\text{C}$
Peak forward current	AllInGaP red: $t_p = 10\text{ }\mu\text{s}$, $t_p/T = 0.05$; InGaN green, blue: $t_p = 100\text{ }\mu\text{s}$, $t_p/T = 0.1$	I_{FM}	300	250	250	mA
Thermal resistance junction to solder point		R_{thJS}	160	130	130	K/W
Operating temperature		T_{amb}	-40 to +110			$^{\circ}\text{C}$
Storage temperature		T_{stg}	-40 to +110			$^{\circ}\text{C}$
ESD voltage	HBM	V_{ESD}	2000	8000	8000	V
Soldering temperature	Reflow	T_{stg}	260			$^{\circ}\text{C}$

OPTICAL AND ELECTRICAL CHARACTERISTICS ($T_{amb} = 25\text{ }^{\circ}\text{C}$, unless otherwise specified) VLMRGB6122.., RED, GREEN, BLUE							
PARAMETER	TEST CONDITION	COLOR	SYMBOL	MIN.	TYP.	MAX.	UNIT
Luminous intensity	$I_F = 20\text{ mA}$	Red	I_v	710	900	1400	mcd
		Green		1800	2200	2800	
		Blue		280	320	450	
Color coordinates x, y acc. to CIE 1931		Red	x, y	-	0.6951, 0.3047	-	
		Green		-	0.1446, 0.7456	-	
		Blue		-	0.1525, 0.0250	-	
Dominant wavelength		Red	λ_d	618	623	630	nm
		Green		520	527	535	
		Blue		450	455	462	
Peak wavelength		Red	λ_p	-	630	-	nm
		Green		-	521	-	
		Blue		-	451	-	
Spectral half width at 50 % I_{rel} max.	Red	$\Delta\lambda_{0.5}$	-	18	-	nm	
	Green		-	33	-		
	Blue		-	19	-		
Angle of half intensity	Red	ϕ	-	120	-	$^{\circ}$	
	Green		-	120	-		
	Blue		-	120	-		
Forward voltage	Red	V_F	1.75	1.95	2.75	V	
	Green		2.5	2.75	3.5		
	Blue		2.5	3.0	3.5		

Notes

- Measurement accuracy: $\pm 8\%$ for luminous intensity, $\pm 1\text{ nm}$ for dominant wavelength, $\pm 0.05\text{ V}$ for forward voltage



LUMINOUS INTENSITY CLASSIFICATION at 20 mA			
COLOR	GROUP	LUMINOUS INTENSITY (mcd)	
		MIN.	MAX.
RED	V1	710	900
	V2	900	1120
	AA	1120	1400
GREEN	BA	1800	2240
	BB	2240	2800
BLUE	T1	280	355
	T2	355	450

Note

- Tolerance on each luminous intensity bin is $\pm 8\%$.
The above classification represents the brightness range which includes only a few brightness groups.
Only one luminous intensity group per color will be shipped on each reel (there will be no mixing of two groups on each reel).
In order to ensure availability, single brightness groups will not be orderable.

DOMINANT WAVELENGTH CLASSIFICATION at 20 mA								
COLOR	GROUP	DOMINANT WAVELENGTH (nm)		CORRESPONDING CIE 1931 COLOR COORDINATES				
		MIN.	MAX.	COORD.	1	2	3	4
RED	R1	618	622	x	0.6837	0.6918	0.6954	0.6873
				y	0.3128	0.3048	0.3045	0.3126
	R2	622	626	x	0.6918	0.6985	0.7022	0.6954
				y	0.3048	0.2981	0.2977	0.3045
	R3	626	630	x	0.6985	0.7042	0.7079	0.7022
				y	0.2981	0.2924	0.2920	0.2977
GREEN	G1	520	525	x	0.1391	0.1624	0.1448	0.1183
				y	0.7087	0.7178	0.7572	0.7487
	G2	525	530	x	0.1624	0.1882	0.1737	0.1448
				y	0.7178	0.7172	0.7557	0.7572
	G3	530	535	x	0.1882	0.2143	0.2035	0.1737
				y	0.7172	0.7133	0.7476	0.7557
BLUE	B1	450	454	x	0.1598	0.1562	0.1522	0.1566
				y	0.0234	0.0285	0.0216	0.0177
	B2	454	458	x	0.1562	0.1521	0.1476	0.1522
				y	0.0285	0.0351	0.0277	0.0216
	B3	458	462	x	0.1521	0.1476	0.1422	0.1476
				y	0.0351	0.0437	0.0353	0.0277

Note

- Tolerance of dominant wavelength is: ± 1 nm.
The above classification represents the color range which includes only a few color groups.
Only one color group per color will be shipped on each reel (there will be no mixing of two groups on each reel).
In order to ensure availability, single color groups will not be orderable.

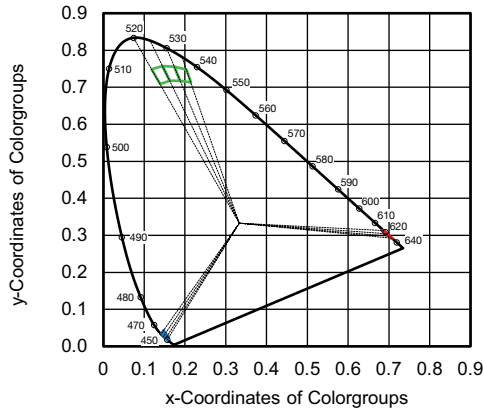

Fig. 1 - CIE 1931 Color Coordinates - RGB

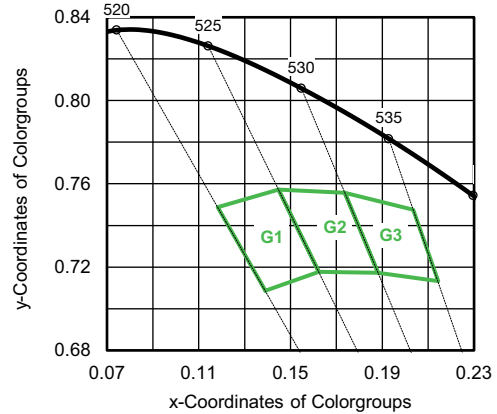

Fig. 3 - CIE 1931 Color Coordinates - Green

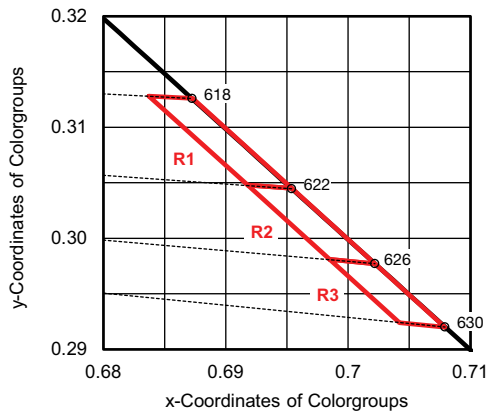

Fig. 2 - CIE 1931 Color Coordinates - Red

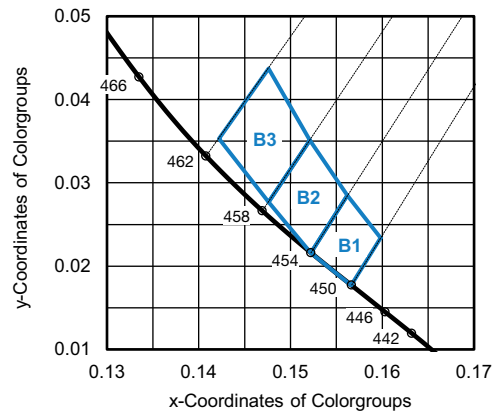

Fig. 4 - CIE 1931 Color Coordinates - Blue

FORWARD VOLTAGE CLASSIFICATION at 20 mA		
GROUP	FORWARD VOLTAGE (V)	
	MIN.	MAX.
D	1.75	2.00
E	2.00	2.25
F	2.25	2.50
G	2.50	2.75
H	2.75	3.00
J	3.00	3.25
K	3.25	3.50

Tolerance of forward voltage is: ± 0.05 V.

The above classification represents the forward voltage range which includes only a few forward voltage groups.

Only one forward voltage group per color will be shipped on each reel (there will be no mixing of two groups on each reel).

In order to ensure availability, single forward voltage groups will not be orderable.

MARKING EXAMPLE FOR SELECTION CODE ON LABEL

V2R2DBAG2GT1B2J (sequence: each 5 characters for red, green, blue for I_V , λ_d and V_F group combination)

- Red:V2R2D→ V2: 900 mcd to 1120 mcd, R2: 622 nm to 626 nm, D: 1.75 V to 2.00 V
- Green:BAG2G→ BA: 1800 mcd to 2240 mcd, G2: 525 nm to 530 nm, G: 2.50 V to 2.75 V
- Blue:T1B2J→ T1: 280 mcd to 355 mcd, B2: 454 nm to 458 nm, J: 3.00 V to 3.25 V

TYPICAL CHARACTERISTICS ($T_{amb} = 25\text{ }^\circ\text{C}$, unless otherwise specified)

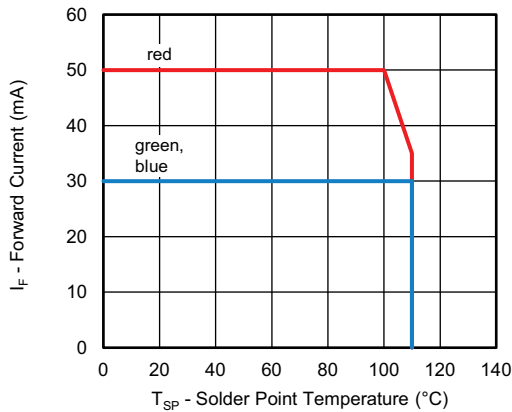

Fig. 5 - Forward Current vs. Solder Point Temperature

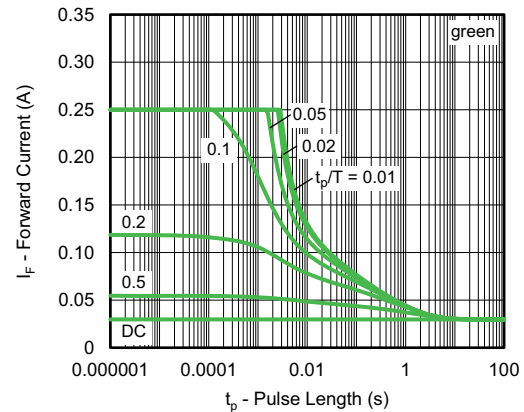

Fig. 7 - Pulse Forward Current vs. Pulse Duration (VLMRGB6122-B00-08, green)

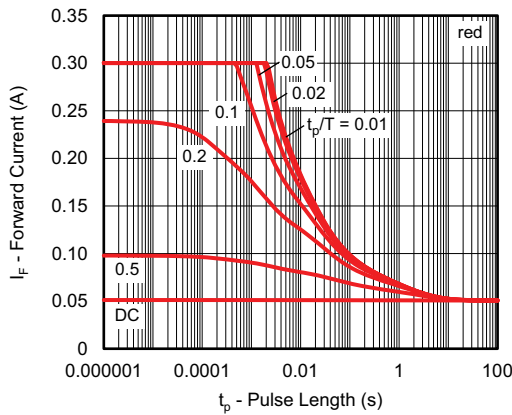

Fig. 6 - Pulse Forward Current vs. Pulse Duration (VLMRGB6122-B00-08, red)

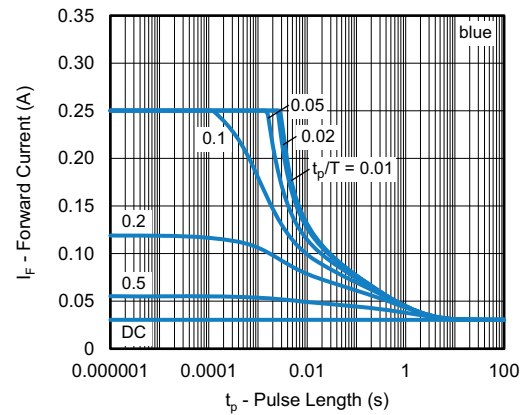

Fig. 8 - Pulse Forward Current vs. Pulse Duration (VLMRGB6122-B00-08, blue)

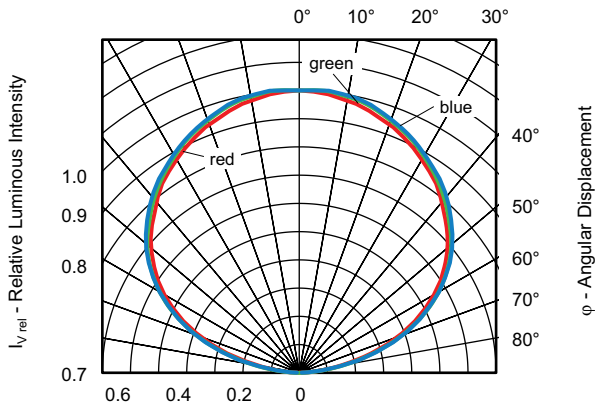

Fig. 9 - Relative Luminous Intensity vs. Angular Displacement

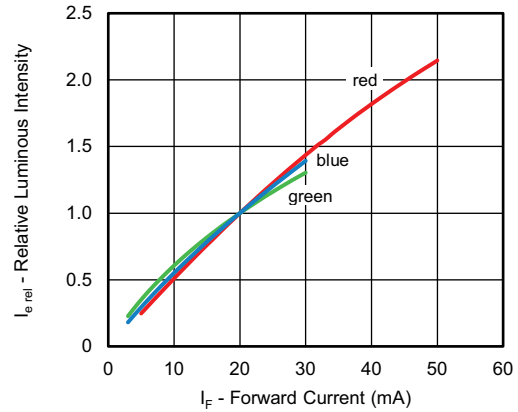

Fig. 12 - Relative Luminous Intensity vs. Forward Current

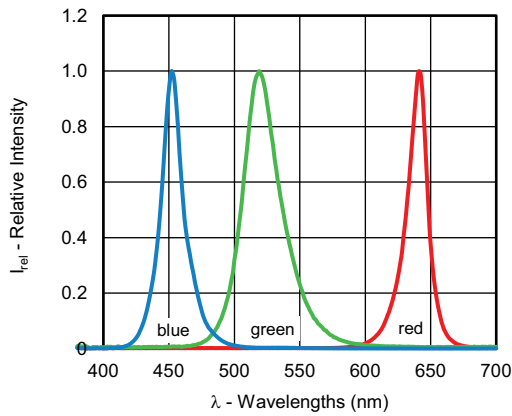

Fig. 10 - Relative Intensity vs. Wavelength

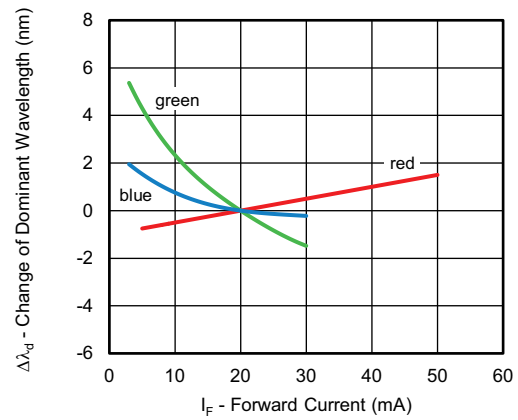

Fig. 13 - Change of Dominant Wavelength vs. Forward Current

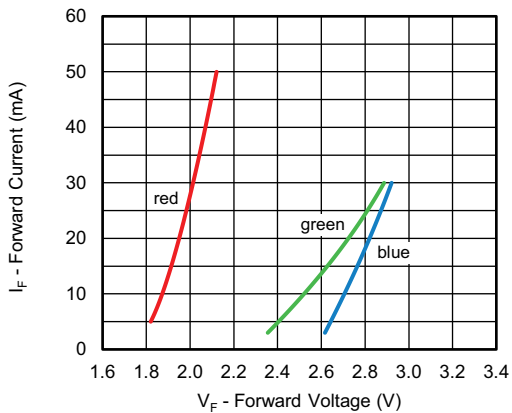

Fig. 11 - Forward Current vs. Forward Voltage

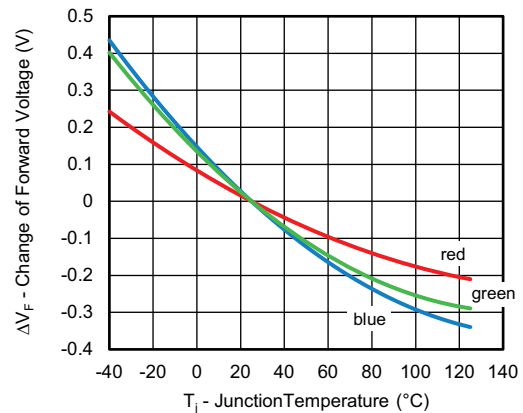

Fig. 14 - Change of Forward Voltage vs. Junction Temperature

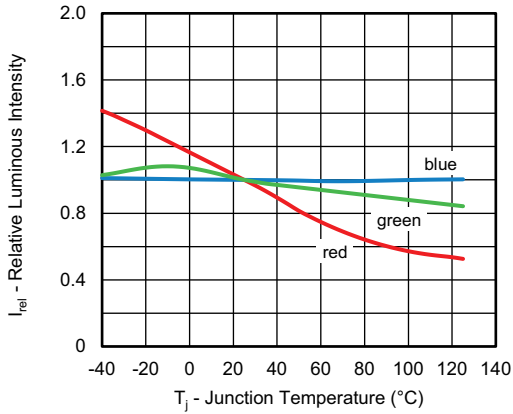

Fig. 15 - Relative Luminous Intensity vs. Junction Temperature

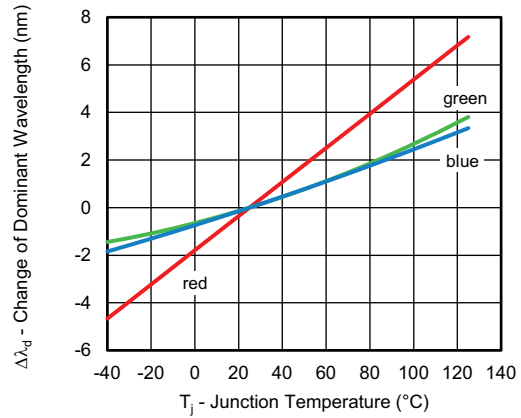
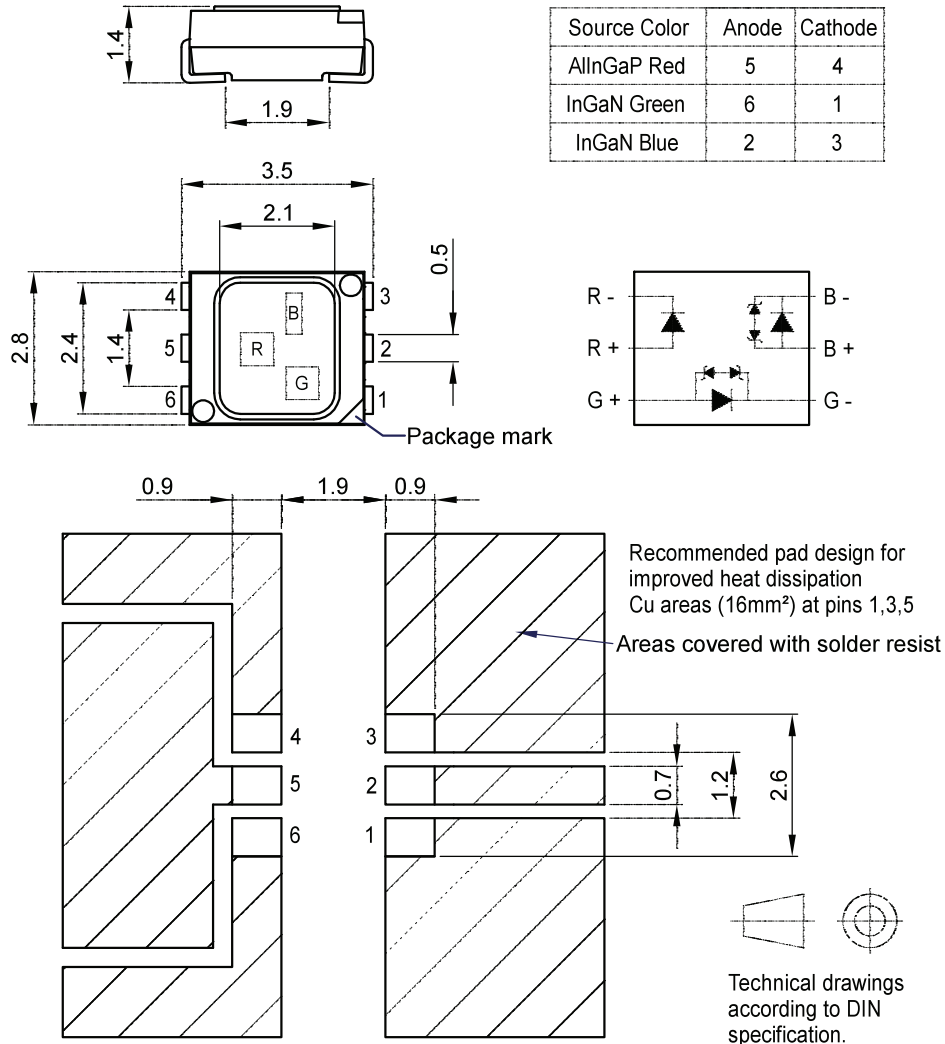

Fig. 16 - Change of Dominant Wavelength vs. Junction Temperature

PACKAGE DIMENSIONS / SOLDERING PADS DIMENSIONS in millimeters



Drawing-No.:
Issue: P1;

Not indicated tolerances ± 0.1

TAPING DIMENSIONS in millimeters

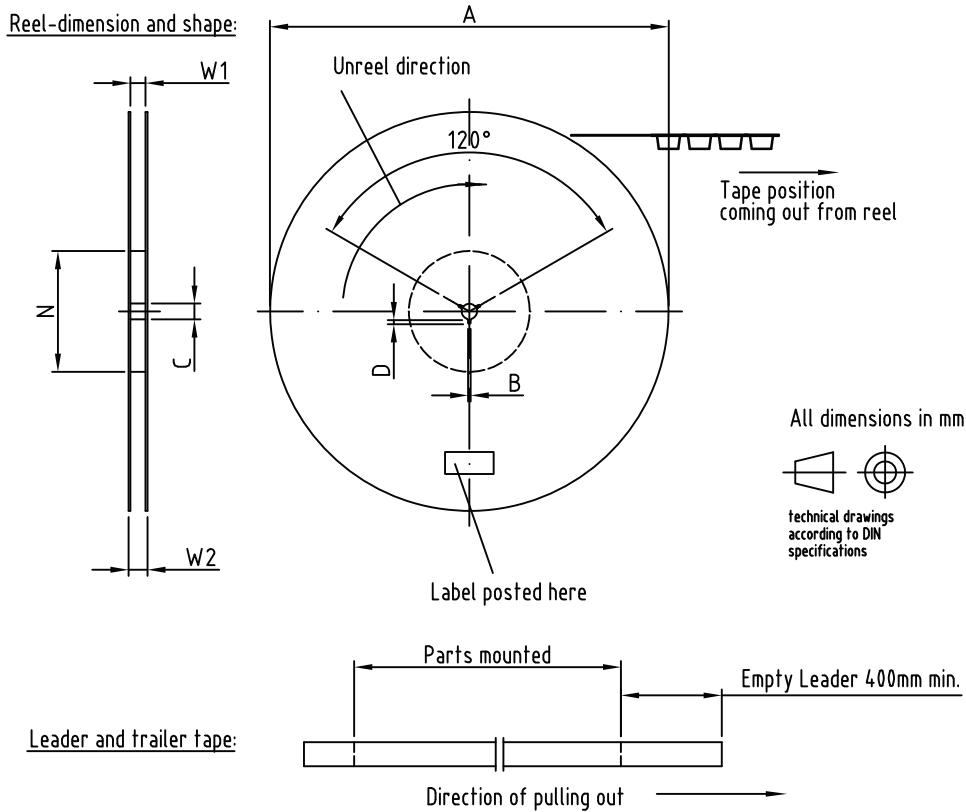

Drawing-No.: 9.800-5172.01
Issue: VK; 18.04.24

QTY per reel: 2000 pcs

REEL DIMENSIONS							
TAPING VERSION	REEL DIMENSIONS IN mm ACCORDING DRAWING REFERENCE						
	A	B	C	D	N	W1	W2
GS08	178 ± 1	2.2 ± 0.5	13 ± 0.5	4 ± 0.5	60 ± 1	9 ± 1	12 ± 1

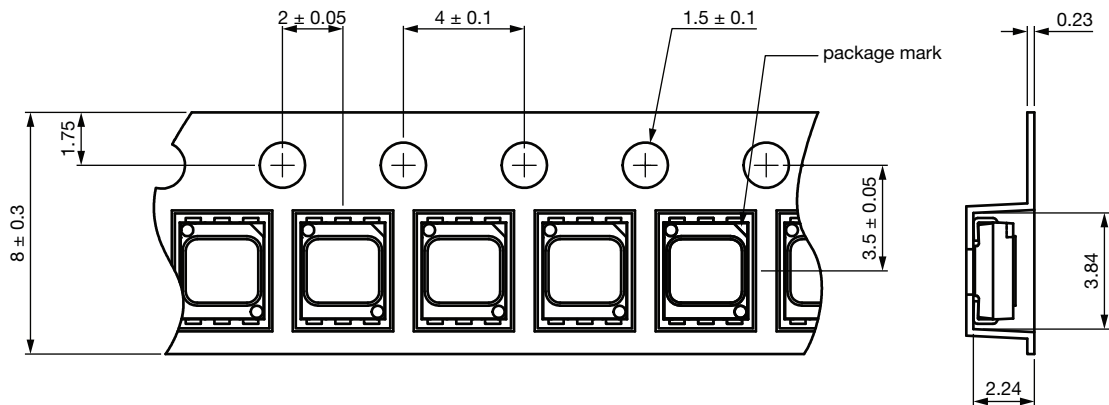

SOLDERING PROFILE

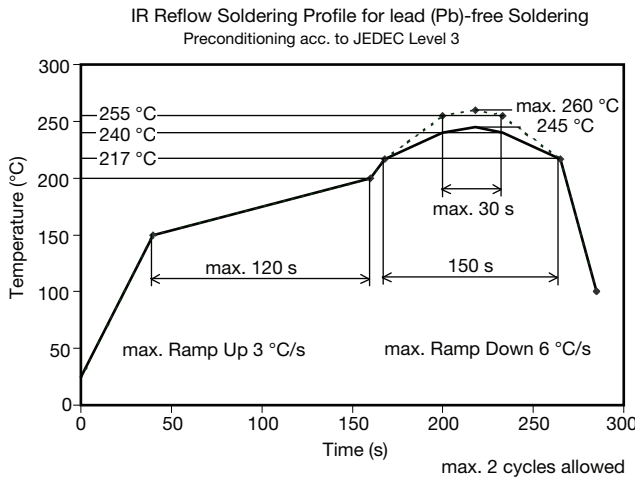
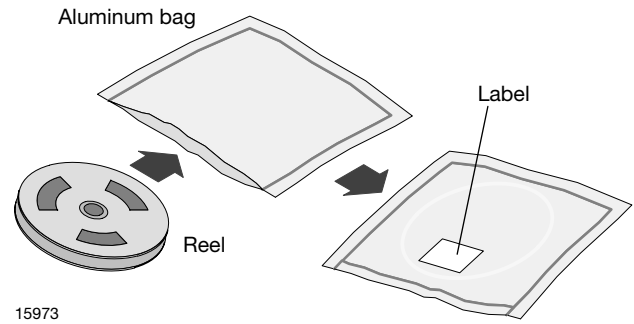

Fig. 17 - Vishay Lead (Pb)-free Reflow Soldering Profile According to J-STD-020



15973

FINAL PACKING

The sealed reel is packed into a cardboard box. A secondary cardboard box is used for shipping purposes.

RECOMMENDED METHOD OF STORAGE

Dry box storage is recommended as soon as the aluminum bag has been opened to prevent moisture absorption. The following conditions should be observed, if dry boxes are not available:

- Storage temperature 10 °C to 30 °C
- Storage humidity ≤ 60 % RH max.

After more than 168 h under these conditions moisture content will be too high for reflow soldering.

In case of moisture absorption, the devices will recover to the former condition by drying under the condition given in J-STD-033.

A JEDEC J-STD-033 level 3 label is included on all aluminum dry bags.

BAR CODE PRODUCT LABEL (example)

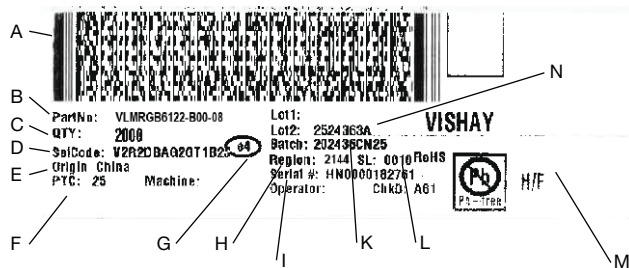

- A. 2D bar code
- B. Part No: Vishay part number
- C. QTY: quantity
- D. SelCode: selection bin code
- E. Country of origin
- F. PTC: production plant code
- G. Termination finish
- H. Region code
- I. Serial#: serial number
- K. Batch Number: year, week, country code, plant code
- L. SL: storage location
- M. Environmental Symbols: RoHS, lead (Pb)-free, halogen-free
- N. Lot numbers

DRY PACKING

The reel is packed in an anti-humidity bag to protect the devices from absorbing moisture during transportation and storage.

CAUTION
This bag contains
MOISTURE-SENSITIVE DEVICES

LEVEL (MSL)

3

1. Calculated shelf life in sealed bag: 12 months at <40°C and < 90% relative humidity (RH)
2. Peak package body temperature: 260°C
3. After bag is opened, devices that will be subjected to reflow solder or other high temperature process must be
 - a) Mounted within **168 h** of factory conditions ≤ 30°C/60%RH, or
 - b) Stored per J-STD-033.
4. Devices require bake before mounting, if:
 - a) Humidity Indicator Card reads >10% for level 2a - 5a devices or >60% for level 2 devices when read at 23 ± 5 °C
 - b) 3a or 3b are not met
5. If baking is required, refer to IPC/JEDEC J-STD-033 for bake procedure

Bag Seal Date: _____
If blank, see adjacent bar code label

Note: Level (MSL) and body temperature defined by IPC/JEDEC J-STD-020

Example of JEDEC J-STD-033 level 3 label



ESD PRECAUTION

Proper storage and handling procedures should be followed to prevent ESD damage to the devices especially when they are removed from the antistatic shielding bag. Electrostatic sensitive devices warning labels are on the packaging.

VISHAY SEMICONDUCTORS STANDARD BAR CODE LABELS

The Vishay Semiconductors standard bar code labels are printed at final packing areas. The labels are on each packing unit and contain Vishay Semiconductors specific data.



Disclaimer

ALL PRODUCT, PRODUCT SPECIFICATIONS AND DATA ARE SUBJECT TO CHANGE WITHOUT NOTICE TO IMPROVE RELIABILITY, FUNCTION OR DESIGN OR OTHERWISE.

Vishay Intertechnology, Inc., its affiliates, agents, and employees, and all persons acting on its or their behalf (collectively, "Vishay"), disclaim any and all liability for any errors, inaccuracies or incompleteness contained in any datasheet or in any other disclosure relating to any product.

Vishay makes no warranty, representation or guarantee regarding the suitability of the products for any particular purpose or the continuing production of any product. To the maximum extent permitted by applicable law, Vishay disclaims (i) any and all liability arising out of the application or use of any product, (ii) any and all liability, including without limitation special, consequential or incidental damages, and (iii) any and all implied warranties, including warranties of fitness for particular purpose, non-infringement and merchantability.

Statements regarding the suitability of products for certain types of applications are based on Vishay's knowledge of typical requirements that are often placed on Vishay products in generic applications. Such statements are not binding statements about the suitability of products for a particular application. It is the customer's responsibility to validate that a particular product with the properties described in the product specification is suitable for use in a particular application. Parameters provided in datasheets and / or specifications may vary in different applications and performance may vary over time. All operating parameters, including typical parameters, must be validated for each customer application by the customer's technical experts. Product specifications do not expand or otherwise modify Vishay's terms and conditions of purchase, including but not limited to the warranty expressed therein.

Hyperlinks included in this datasheet may direct users to third-party websites. These links are provided as a convenience and for informational purposes only. Inclusion of these hyperlinks does not constitute an endorsement or an approval by Vishay of any of the products, services or opinions of the corporation, organization or individual associated with the third-party website. Vishay disclaims any and all liability and bears no responsibility for the accuracy, legality or content of the third-party website or for that of subsequent links.

Vishay products are not designed for use in life-saving or life-sustaining applications or any application in which the failure of the Vishay product could result in personal injury or death unless specifically qualified in writing by Vishay. Customers using or selling Vishay products not expressly indicated for use in such applications do so at their own risk. Please contact authorized Vishay personnel to obtain written terms and conditions regarding products designed for such applications.

No license, express or implied, by estoppel or otherwise, to any intellectual property rights is granted by this document or by any conduct of Vishay. Product names and markings noted herein may be trademarks of their respective owners.