

Features

- High isolation 3750 VRMS
- DC input with random-phase photo triac output
- Operating temperature range - 40°C to 110 °C
- REACH & RoHS compliance
- Halogen free
- MSL class 1
- Regulatory Approvals
 - UL - UL1577
 - VDE - EN60747-5-5(VDE0884-5)
 - CQC - GB4943.1

Applications

- Switching power supply, intelligent meter
- Industrial control, measuring instruments
- Office equipment such as copiers
- Household appliances: such as air conditioners, fans, water heaters, etc.

Description

The MOC3053 series combine an GaAs infrared emitting diode as the emitter which is optically coupled to a monolithic silicon random-phase photo triac in a plastic SOP4 package.

With the robust coplanar double mold structure, MOC3053 series provide the most stable isolation feature.

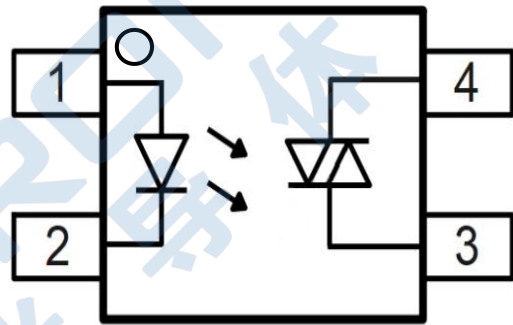

ORDERING INFORMATION

Outline	Part Number	Package	Marking	Packing	Packing Size	Quantity
	MOC3053-SVS	SOP4	MOC3053 /YYWW D	Reel	13 "	3000

CONTENTS

Pin Configuration And Functions.3
Absolute Maximum Ratings.3
Electrical Optical Characteristics.4
Characteristic Curves.5
Test Circuits.6
Package Dimensions.7
Recommended Solder Mask7
Carrier Tape Specifications8
Ordering And Marking Information9
Reflow Information10
Temperature Profile Of Soldering.11
Disclaimer12

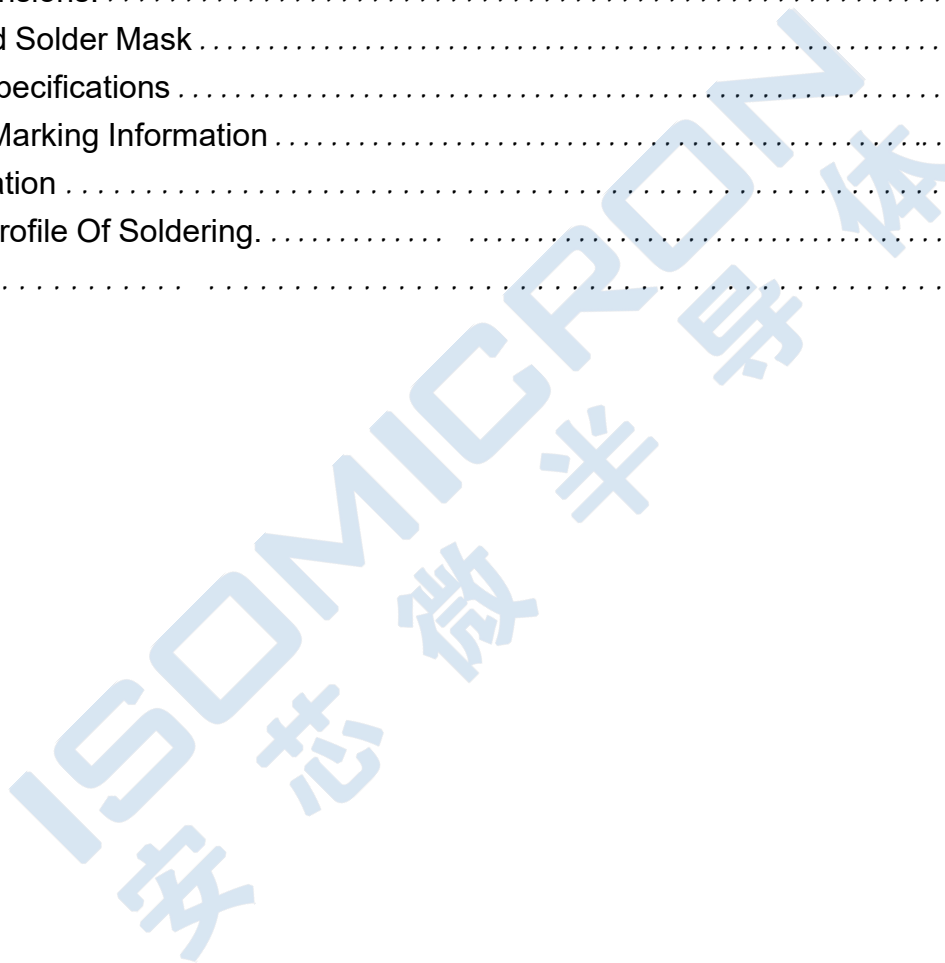

PIN CONFIGURATION AND FUNCTIONS

	Pin	Name
	1	Anode
	2	Cathode
	3	Terminal
	4	Terminal

ABSOLUTE MAXIMUM RATINGS

Parameter	Symbol	Value	Unit	Note
INPUT				
Forward Current	I_F	60	mA	
Reverse Voltage	V_R	6	V	
Junction Temperature	T_j	125	°C	
Input Power Dissipation	P_I	100	mW	
OUTPUT				
Off-state Output Terminal Voltage	V_{DRM}	600	V	
Peak Repetitive Surge Current PW=100μs, 120pps	I_{TSM}	1	A	
Junction Temperature	T_j	125	°C	
Output Power Dissipation	P_O	300	mW	
COMMON				
Total Power Dissipation	P_{tot}	330	mW	
Isolation Voltage	V_{iso}	3750	Vrms	1
Operating Temperature	T_{opr}	-40~110	°C	
Storage Temperature	T_{stg}	-55~125	°C	
Soldering Temperature	T_{sol}	260	°C	2

Note 1. AC For 1 Minute, R.H. = 40 ~ 60%

Note 2. For 10 seconds

ELECTRICAL OPTICAL CHARACTERISTICS(T_a=25°C)

Parameter	Symbol	Min.	Typ.	Max.	Unit	Test Condition	Note
INPUT							
Forward Voltage	V _F	-	1.24	1.4	V	I _F = 10mA	
Reverse Current	I _R	-	-	10	μA	V _R = 6V	
Input Capacitance	C _{in}	-	10	250	pF	V = 0, f = 1kHz	
OUTPUT							
Peak Off-state Current, Either Direction	I _{DRM}	-	-	100	nA	V _{DRM} = Rated V _{DRM} I _F =0	1
Peak On-state Voltage, Either Direction	V _{TM}	-	2	2.5	V	I _{TM} = 100mA peak I _F = Rated I _{FT}	
Critical Rate of Rise of Off-state Voltage	dV/dt	1	-	-	KV/μs	V _{PEAK} = Rated V _{DRM}	
TRANSFER CHARACTERISTICS							
LED Trigger Current	I _{FT}	-	-	5	mA	Terminal Voltage = 3V I _{TM} =100mA	
Holding Current	I _H	-	110	-	μA		
Isolation Resistance	R _{iso}	10 ¹²	10 ¹⁴	-	Ω	DC500V, 40 ~ 60% R.H.	
Isolation capacitance	C _{iso}	-	0.3	1	pF	f=1MHz	

Note 1. Test voltage must be applied within dV/dt rating.

CHARACTERISTIC CURVES

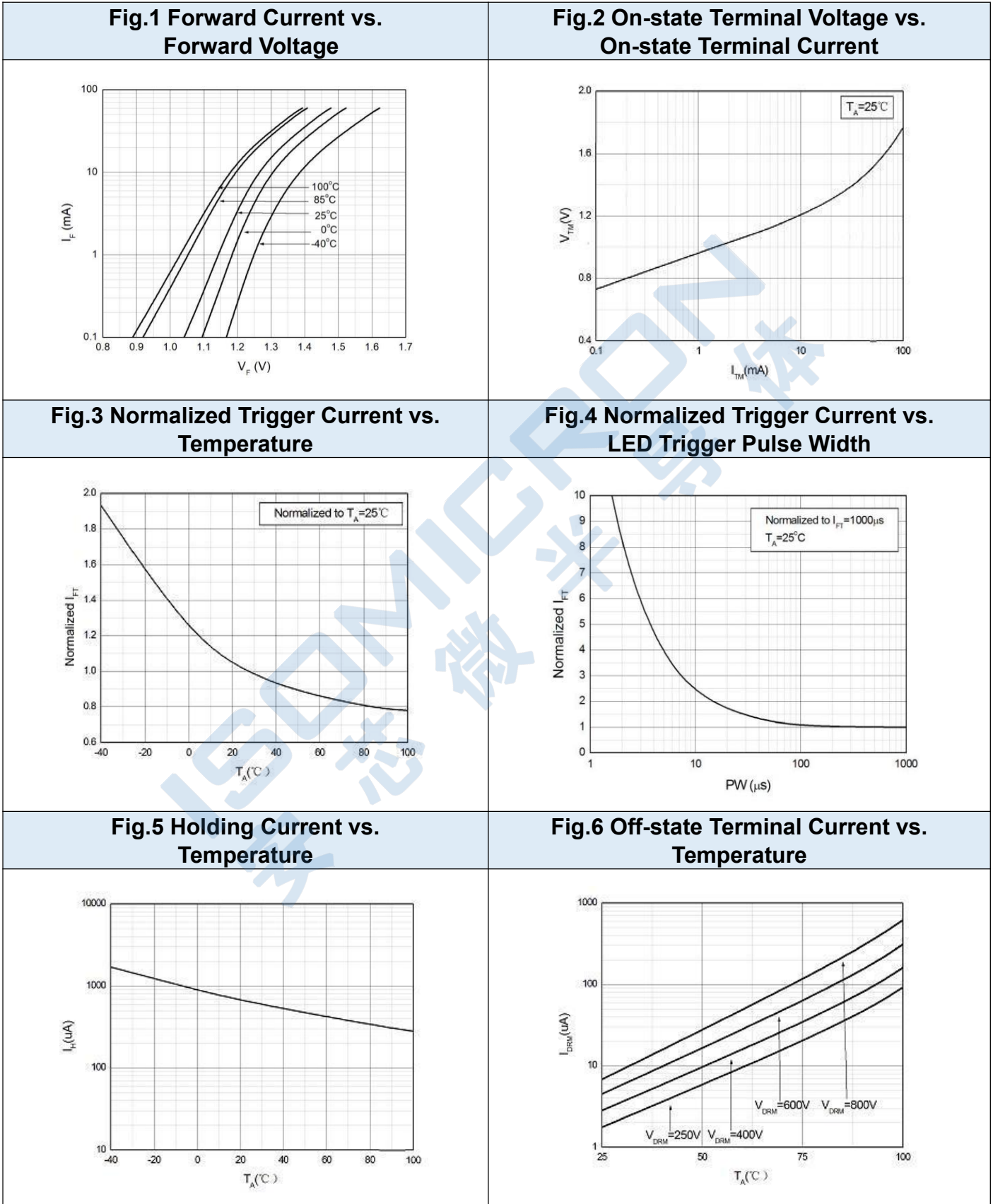

TEST CIRCUITS

Fig.7 Test Circuits of dV/dt

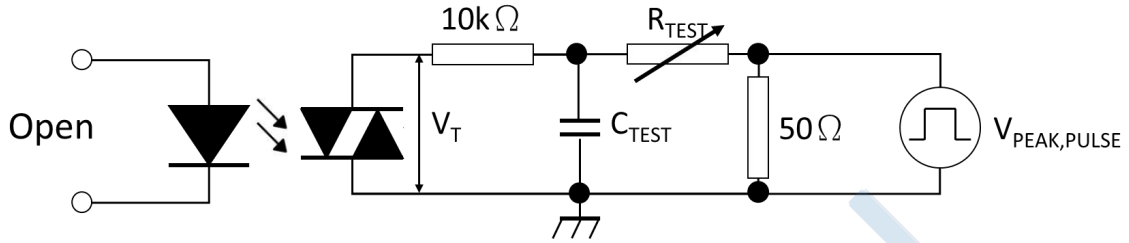
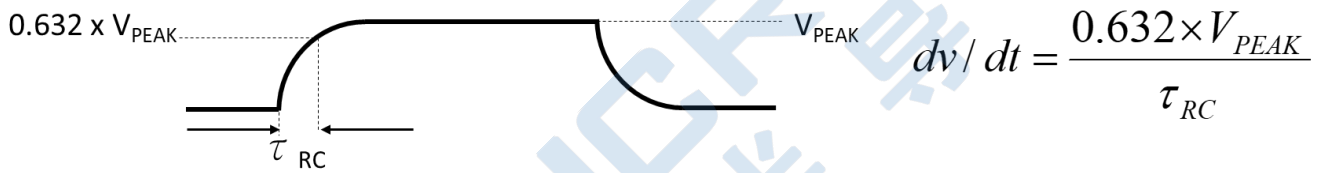
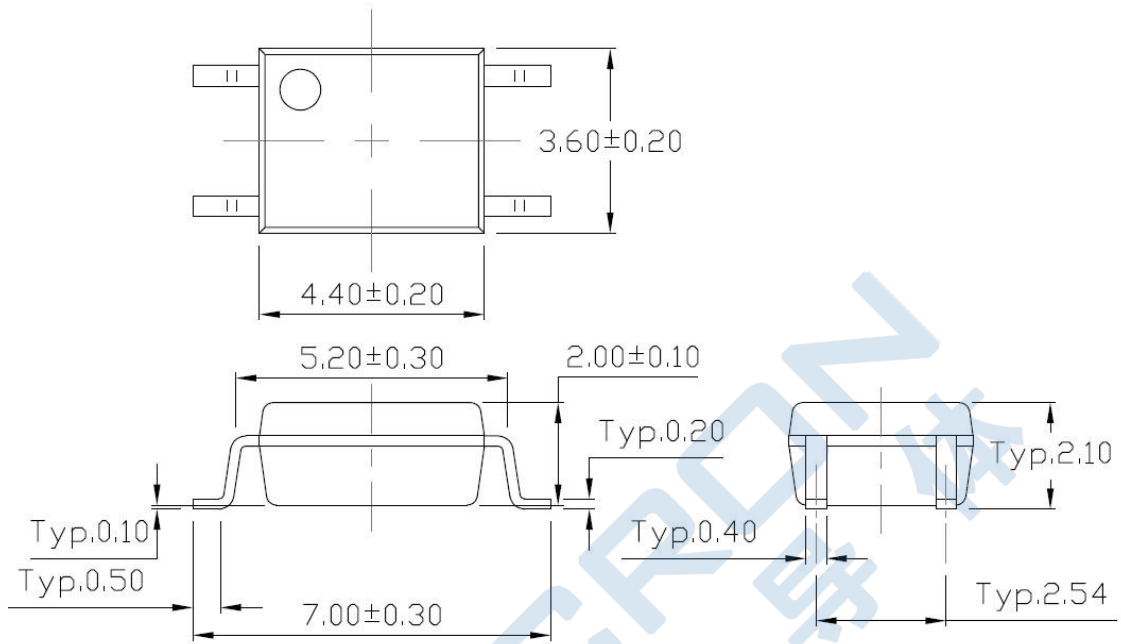

Fig.8 Waveforms of dV/dt



PACKAGE DIMENSIONS

Surface Mount (Low Profile) - (SOP4)



Recommended Solder Mask

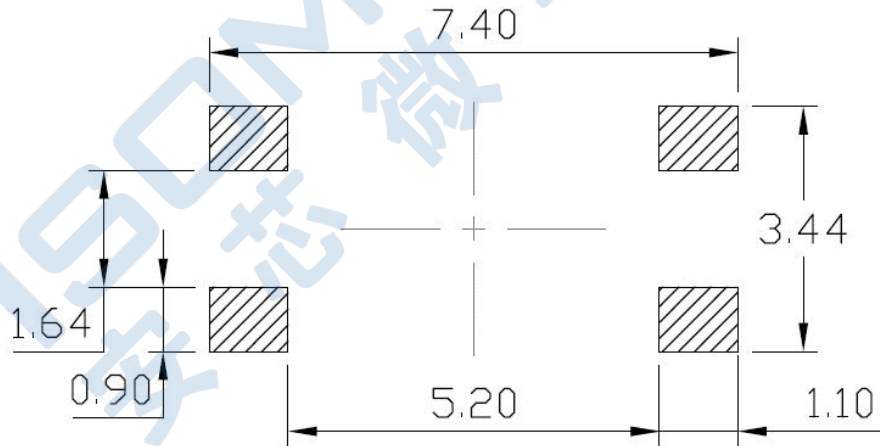

- Dimensions in mm unless otherwise stated

CARRIER TAPE SPECIFICATIONS

Option SM-SL

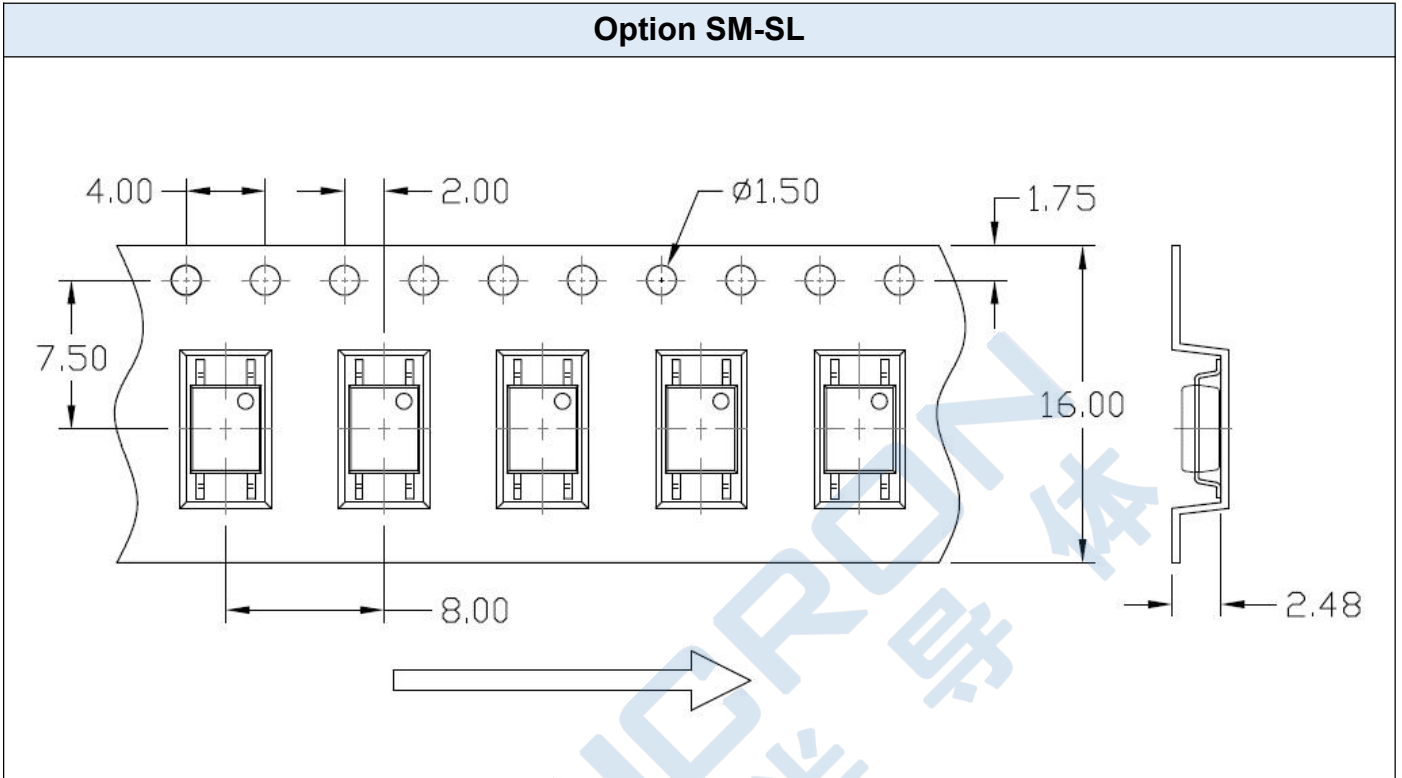

- Dimensions in mm unless otherwise stated

ORDERING AND MARKING INFORMATION

Marking Information			
		<p>MOC : Product Series 3053 : Part Number / : ISOMICRON YY : Fiscal Year WW : Work Week Z : Manufacturing Code</p>	
Order Code			
<p>MOC 30XX - X X X</p>			
<p>Product Series</p>	←		
<p>Part Number 3053</p>	←		<p>Lead Forming: S: SM-SL</p>
<p>Package Option: S: SOP4</p>	←		<p>VDE Option: V or None, V-VDE approval</p>
Packing Quantity			
Option	Quantity	Quantity – Inner box	Quantity – Outer box
SM-SL	3000 Units/Reel	2 Reels/Inner box	5 Inner box/Outer box = 30k Units

REFLOW INFORMATION

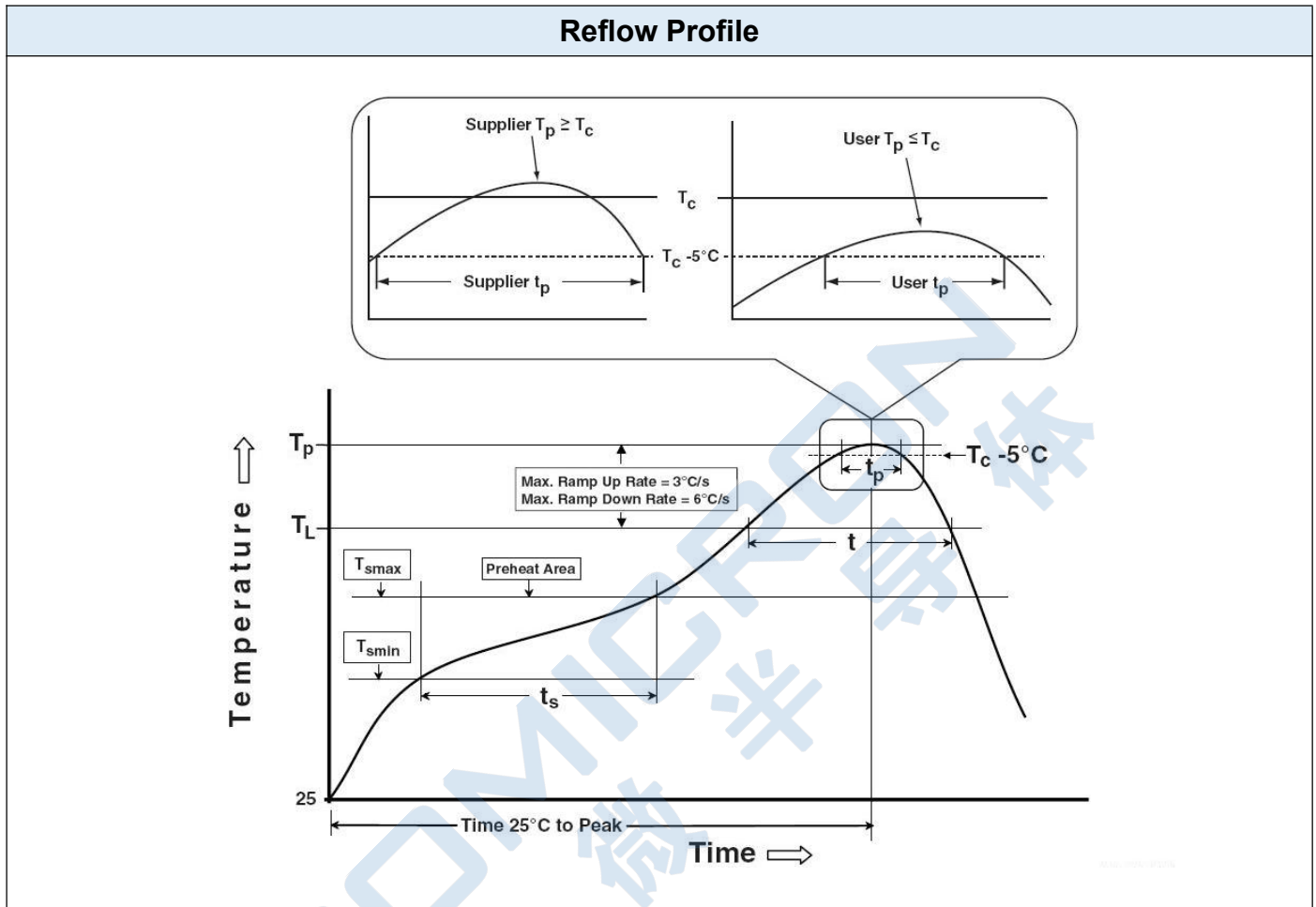

Profile Feature	Sn-Pb Assembly Profile	Pb-Free Assembly Profile
Temperature Min. (T _{smin})	100	150°C
Temperature Max. (T _{smax})	150	200°C
Time (t _s) from (T _{smin} to T _{smax})	60-120 seconds	60-120 seconds
Ramp-up Rate (t _L to t _P)	3°C/second max.	3°C/second max.
Liquidous Temperature (T _L)	183°C	217°C
Time (t _L) Maintained Above (T _L)	60 – 150 seconds	60 – 150 seconds
Peak Body Package Temperature	235°C +0°C / -5°C	260°C +0°C / -5°C
Time (t _P) within 5°C of 260°C	20 seconds	30 seconds
Ramp-down Rate (T _P to T _L)	6°C/second max	6°C/second max
Time 25°C to Peak Temperature	6 minutes max.	8 minutes max.

TEMPERATURE PROFILE OF SOLDERING

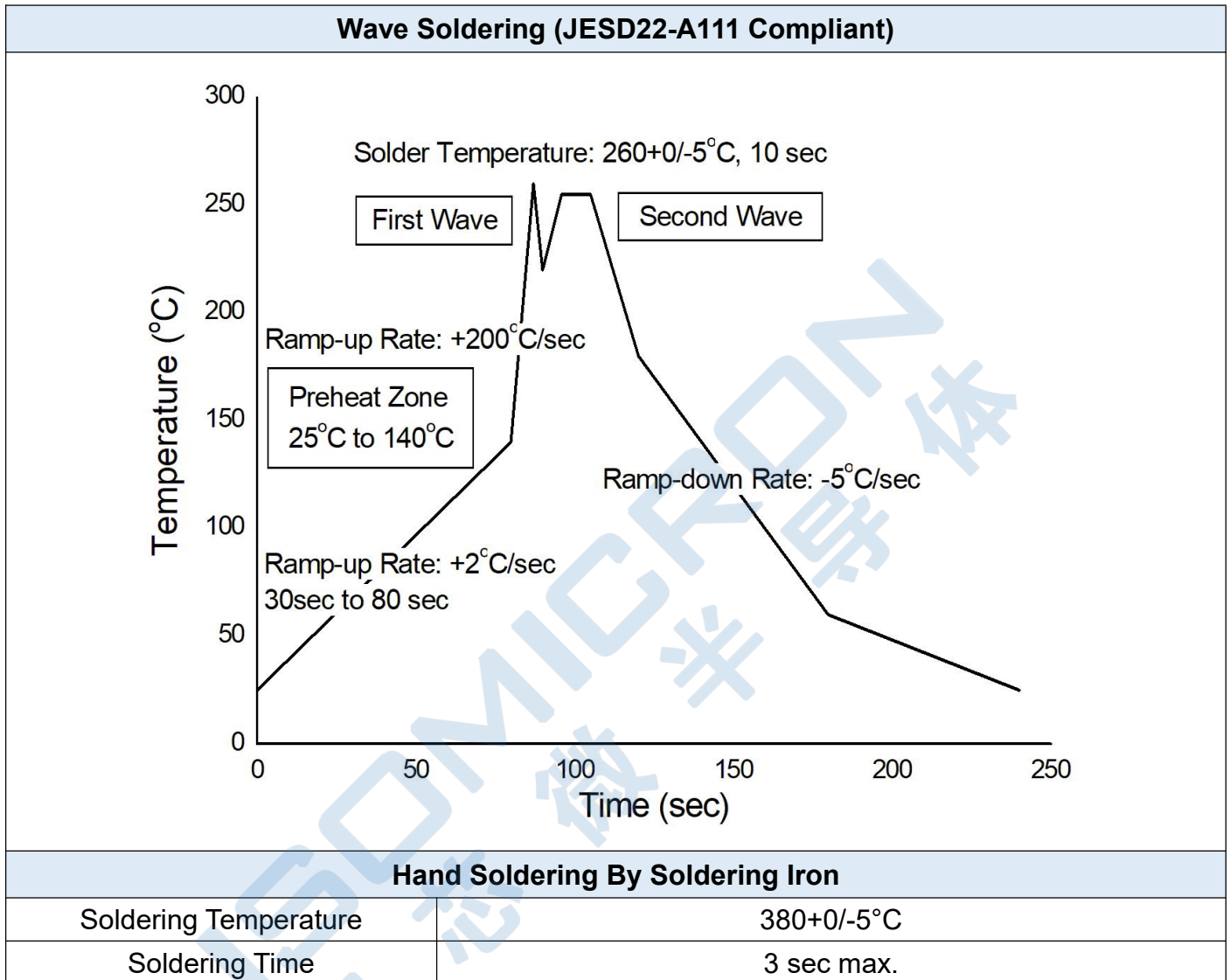

- One time soldering is recommended for all soldering method.
- Do not solder more than three times for IR reflow soldering.

DISCLAIMER

- ISOMICRON is continually improving the quality, reliability, function and design. ISOMICRON reserves the right to make changes without further notices.
- The characteristic curves shown in this datasheet are representing typical performance which are not guaranteed.
- ISOMICRON makes no warranty, representation or guarantee regarding the suitability of the products for any particular purpose or the continuing production of any product. To the maximum extent permitted by applicable law, ISOMICRON disclaims (a) any and all liability arising out of the application or use of any product, (b) any and all liability, including without limitation special, consequential or incidental damages, and (c) any and all implied warranties, including warranties of fitness for particular
- The products shown in this publication are designed for the general use in electronic applications such as office automation, equipment, communications devices, audio/visual equipment, electrical application and instrumentation purpose, non-infringement and merchantability.
- This product is not intended to be used for military, aircraft, automotive, medical, life sustaining or lifesaving applications or any other application which can result in human injury or death.
- Please contact ISOMICRON sales agent for special application request.
- Immerge unit's body in solder paste is not recommended.
- Parameters provided in datasheets may vary in different applications and performance may vary over time. All operating parameters, including typical parameters, must be validated in each customer application by the customer's technical experts. Product specifications do not expand or otherwise modify ISOMICRON's terms and conditions of purchase, including but not limited to the warranty expressed therein.
- Discoloration might be occurred on the package surface after soldering, reflow or long-time use. It neither impacts the performance nor reliability.