

保密等级: 绝密 保密 普通

符合RoHS 环保要求

版次 工程变更单号

基本描述

日期

修订

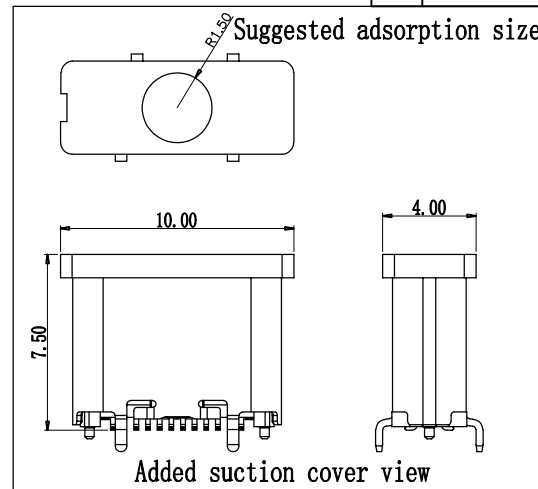
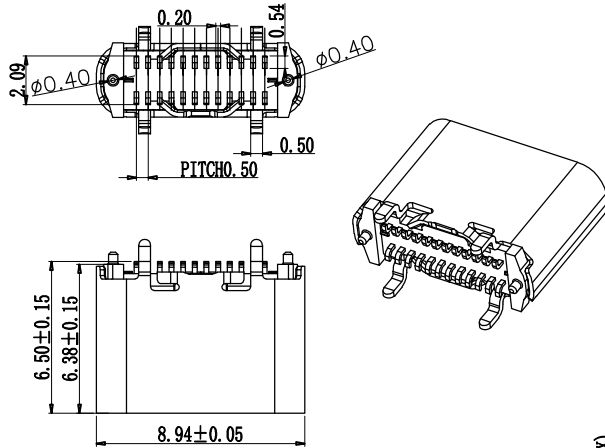

Note:
 1.Material:
 1.1 Housing: LCP
 1.2 Contact:C7025,T=0.15mm
 1.3 Shell: SUS304 T=0.3mm
 2.ELECTRICAL:
 2-1:CURRENT RATING:
 VBUS AND GND CONTACTS RATED AT 1.25A PARALLELED FOR A TOTAL OF 5A;
 2-2:INITIAL CONTACT RESISTANCE :40 MEGOHMS
 2-3:DIELECTRIC WITHSTANDING VOLTAGE: 100V AC MIN;
 3:MECHANICAL CHARACTERISTICS:
 3-1:MATING FORCE:5~20N
 3-2:UNMATING FORCE:8~20N(INITIAL), 6~20N(AFTER 10000 CYCLES)
 3-3:FREQUENCY: 200±50 CYCLES /HOUR, 10000 CYCLES
 3-4:OPERATING TEMPERATURE ;-40°~80°.

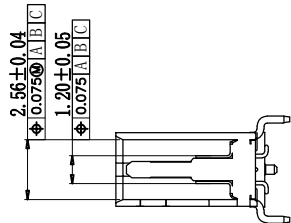

SECTION A-A SCALE 1:1

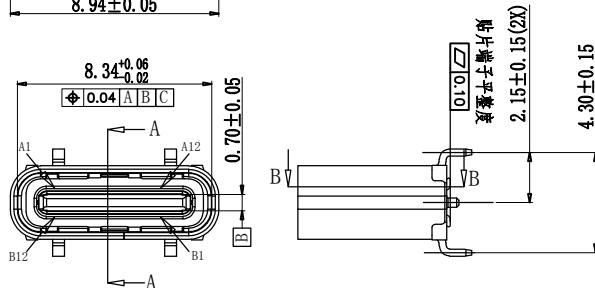

SECTION B-B SCALE 1:1

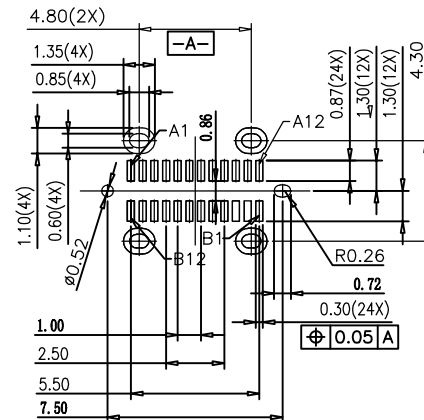
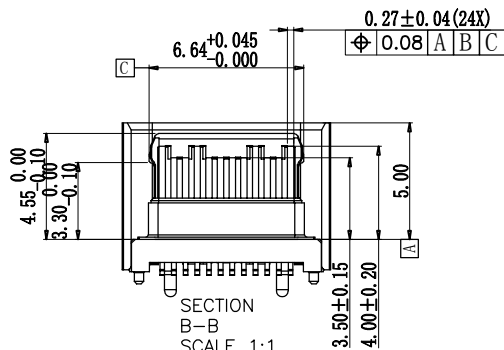

RECOMMENDED P.C.B. LAYOUT TOLERANCE UNSPECIFIED ±0.05mm

A1	GND	B12	GND
A2	SSTXP1	B11	SSRXP1
A3	SSTXN1	B10	SSRXN1
A4	VBUS	B9	VBUS
A5	CC1	B8	SBU2
A6	DP1	B7	DN2
A7	DN1	B6	DP2
A8	SBU1	B5	CC2
A9	VBUS	B4	VBUS
A10	SSRXN2	B3	SSTXN2
A11	SSRXP2	B2	SSTXP2
A12	GND	B1	GND
PIN	SIGNAL NAME	PIN	SIGNAL NAME

东莞市高钺达电子科技有限公司
 惠州市高钺达光电科技有限公司

品名规格	TYPE-C 24PIN直立式母座H=6.50			设计	刘静
未注公差:	料号	TYPE24-L1T1-2065-A		审核	
.000 ±0.10	图纸类型	成品图	比例		
.00 ±0.20	视角	版本	A/O	核准	
.0 ±0.30	角度	单位	MM		
角度 ±1°					