

40V , 600mA , Step-Down Converter

General Description

The MP2451DT is a high frequency (1.8MHz) step-down switching regulator with integrated internal high-side high voltage power MOSFET. It provides single 0.6A(or less) highly efficient output with current mode control for fast loop response. The wide input range(4.2V to 40V) accommodates a variety of step-down applications under mobile environment input conditions.Low shutdown mode quiescent current of 1 μ A is suitable for battery-powered applications.

High efficiency at light load condition is achieved by scaling down the switching frequency to reduce the switching and gate driving losses.The frequency folding technique helps prevent the inductance current from running out of control at startup.Hot shutdown provides reliable, fault tolerant operation.

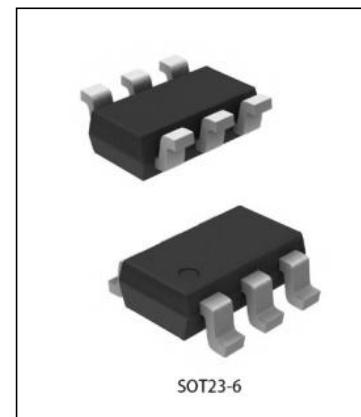

Features

- Output 0.6A peak current
- 230 μ A operating quiescent current
- 4.2 V to 40 V operating input range
- 500m Ω internal power MOSFET
- 1.8 MHz fixed switching frequency
- Internally compensated
- Stable with ceramic output capacitors
- Internal soft-start
- Precision current limit without current sensing resistor
- >90% efficiency
- Low shutdown mode current: <1 μ A
- SOT23-6 package

Applications

- High voltage power conversion
- Automotive systems
- Industrial power system
- Distributed power system
- Battery powered system

Order specification

Part No	Package	Manner of Packing	Devices per bag/reel
MP2451DT-LF-Z	SOT23-6	Reel	3000

Block Diagram and Pin Arrangement Diagram

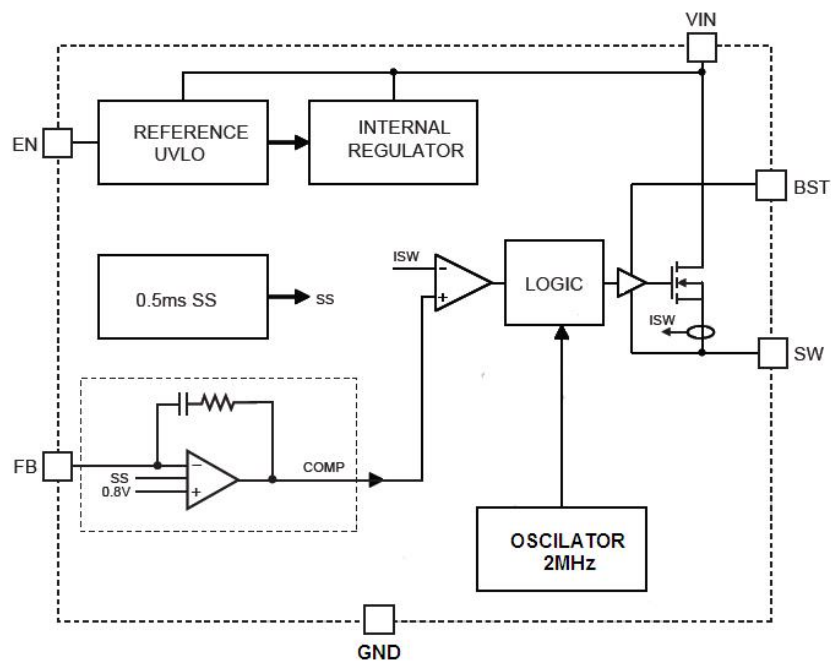

Pin Assignment

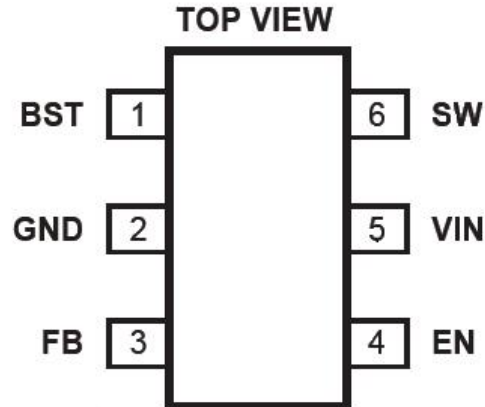

Pin No.	Pin Name	Description
1	BST	Bootstrap. This is the positive power supply for the internal floating high side MOSFET driver. Connect a bypass capacitor between this pin and SW pin.
2	GND	Ground. It should be connected as close as possible to the output capacitor, avoid high current switching paths.
3	FB	Feedback. This is the input to the error amplifier. An external resistive divider connected between the output and GND is compared to the internal +0.8V reference to set the regulation voltage.
4	EN	Enable input. Pull this pin below the specified threshold to disable. Pull it above the specified threshold to enable. Connect 100K resistor to IN, it can be turned on automatically.
5	VIN	Input Supply. All internal control circuits are powered, including switching tubes. A decoupling capacitor to ground is required close to this pin to reduce switching spikes.
6	SW	Switch node. This is the output from the high-side switch. A low VF Schottky diode to ground is required close to this pin to reduce switching spikes.

Absolute Maximum Ratings

Parameter	Symbol	Min.	Max.	Unit
Supply Voltage	V_{IN}	-0.3	43	V
Switch Voltage	V_{SW}	-0.3	$V_{IN(MAX)}+0.3$	V
BST to SW		-0.3	6.0	V
All Other Pins		-0.3	5.0	V
Continuous Power Dissipation(TA=+25°C)	P_D		0.57	W
Junction Temperature	T		150	°C
Lead Temperature	T		260	°C
Storage Temperature	T_{STG}	-65	150	°C
Operating Junction Temp	T_J	-40	125	°C
Junction-to-Ambient Thermal Resistance	θ_{JA}		220	°C/W
Junction-to-Case Thermal Resistance	θ_{JC}		110	°C/W

Recommended Operating Conditions

Parameter	Symbol	Min.	Max.	Unit
Supply Voltage	V_{IN}	4.2	40	V
Switch Voltage	V_{SW}		40	V

Electrical Characteristics

Vin=12V, Ven=2V, Tamb= 25°C, unless specified otherwise.

Parameter	Symbol	Test Conditions	Min	Typ	Max	Unit
Feedback Voltage	Vfb		0.778	0.794	0.810	V
Upper Switch ON Resistance	Rsw	Vbst-Vsw=5V		500		mΩ
Upper Switch Leakage	Iswleak	Ven=0V, Vsw=0V		0.1	1	μA
Limiting Current	Ilim			1		A
Transconductance	Gcs	COMP to SENSE		3		A/V
Minimum Operating Voltage	Vin min		4.2			V
UVLO Up Threshold	Vin(UVLO)		3.3		4.2	V
UVLO Hysteresis	Vin(UVLO)hys			0.8		V
Soft-Start Time	Tss	FB from 0 to 1.8V		0.5		ms
Oscillator Frequency	Fosc		1.4	1.8	2.2	MHz
Minimum Switch ON Time	Ton min			100		ns
Shutdown Current	I _{sd}	Ven<0.3V		3	15	μA
Quiescent Current	I _{sq}	Vfb=0.9V, No load		200		μA
Thermal Shutdown	Temp			150		°C
Enable up threshold	V _{enh}		1.6		2.0	V
Enable Threshold Hysteresis	En hys			0.6		V
Enable Clamp Voltage	En Vclamp			7.5		V

Detailed Description

The MP2451DT is a 1.8MHz, non-synchronous, step-down switching regulator with integrated internal high side MOSFET. It provides internally compensated single 0.6A high efficient output. It features wide input voltage range, internal soft-start control, and precision current limit. Low operational quiescent current feature is suit for battery powered applications.

PWM Control

At heavy load or moderate load condition, the MP2451DT operates in a fixed frequency, peak current control mode to regulate the output voltage. A PWM cycle is initiated by the internal clock. The power MOSFET is turned on and remains on until its current reaches the value set by COMP voltage. When the power switch is off, it remains off for at least 100ns before the next cycle starts.

If, in one PWM period, the current in the power MOSFET does not reach COMP set current value, the power MOSFET remains on, saving a turn-off operation.

Pulse Skipping Mode

Under light load, the circuit enters pulse jump mode to improve light load efficiency.

The determination of pulse jump is based on its internal COMP voltage. If the COMP terminal is below the internal sleep threshold, a pause command is generated to prevent the clock pulse from being turned on, so the power MOSFET cannot be turned on as instructed, saving drive and switching losses. The pause command will also put the entire chip into sleep mode, consuming very low static current to further improve light load efficiency.

When the COMP voltage is above the sleep threshold, the pause signal is reset and the chip returns to normal PWM operation. Each time the pause instruction changes state from low to high, an on signal is immediately generated to turn on the power MOSFET.

Error Amplifier

The error amplifier consists of an internal operational amplifier with a resistance-capacitance feedback network connected between its output (internal COMP node) and negative input (FB). When FB is below its internal reference voltage (REF), the COMP output is driven higher by the op amp, resulting in a higher switching peak current output, and therefore more energy is transferred to the output, and vice versa.

Typically, FB is connected to a voltage divider consisting of RUP and RDN, where THE RDN is connected to FB and ground, while RUP is connected to the voltage output node and FB. RUP controls the gain of the error amplifier in conjunction with the internal compensation RC network.

Internal Regulator

Most of the internal circuitry is powered on by the 2.6V internal regulator. When VIN is higher than 4.0V, the output of the regulator is in full regulation. When VIN is lower, the output degrades.

Enable-control

The circuit has a specialized enable control terminal EN. When the VIN is high enough, the chip can be enabled and disabled via the EN side. The high level is valid. Lower limit 1.6V. Back to 0.6 V. When suspended, the EN terminal is pulled internally to the ground and the chip is disabled. When EN reaches 0V, the chip enters the lowest shutdown current mode. When EN is above zero but below its threshold, the chip remains in shutdown mode but the shutdown current increases slightly.

Under Voltage Lockout (UVLO)

VIN Under voltage lockout (UVLO) is implemented to protect the chip from operating at insufficient supply voltage.

Internal Soft Start

Soft start is used to prevent the output voltage of the converter from overshooting when starting. When the chip is started, the internal circuit generates a soft start voltage (SS) starting from 0V, set by the soft start time, and rising slowly. When it is below the internal reference REF, SS predominates and the error amplifier uses SS instead of REF as a reference. When SS is higher than REF, REF is dominant. SS is also associated with FB. SS can be much lower than FB, but only slightly higher. SS will also track FB falls if FB falls unexpectedly, this feature is designed to deal with short circuit recovery. When the short circuit is eliminated, the SS ramp rises as a soft start process that restarts, preventing output voltage overshoot.

Thermal Shutdown

Thermal shutdown is implemented to prevent the chip from thermally running away. When the temperature is higher than its upper threshold, the MP2451DT will shut down. When the temperature is lower than its lower threshold, the chip is enabled again.

Suspension Drive and Bootstrap Charging

The floating power MOSFET driver is powered by an external bootstrap capacitor. The levitating drive has its own UVLO protection. The opening threshold of the UVLO is about 2.9V and backlash is about 300mV. During UVLO, the SS voltage is reset to zero. When the UVLO is removed, the controller begins the soft start process.

The bootstrap capacitor is charged by an internal bootstrap regulator and held at about 5V. When the voltage between BST and SW falls below the regulated value, a PMOS switch tube connecting VIN to BST is opened, and the charging current goes from VIN, BST and then to SW. The external circuit should provide a sufficient voltage margin to facilitate charging.

As long as the VIN is high enough above the SW, the bootstrap capacitor can be charged. When a power MOSFET is on, VIN is approximately equal to SW, so the bootstrapped capacitor cannot be charged. When the external continuation diode is turned on, the difference between VIN and SW is the largest, which is the best time for charging. When there is no current in the inductor, SW is equal to the output voltage VOUT, and the voltage between VIN and VOUT can be used to charge the bootstrap capacitor. At a high duty cycle, the charging time of the bootstrap capacitor decreases, and the bootstrap capacitor may not be effectively charged.

When the external circuit does not have sufficient voltage and time to charge the bootstrap capacitor, an additional external circuit can be used to ensure the bootstrap voltage within the normal operating range.

The UVLO of the hover drive is not transmitted to the controller.

The dc static current of the suspension driver is about 20 μ A. Make sure the supply current on the SW side is higher than this.

Current Comparator and Current Limit

Power MOSFET current is sampled accurately through a current sampling MOSFET. It is then sent to a high-speed current comparator for current-mode control. The sampling current serves as one of the inputs to the current comparator. When the power MOSFET is on, the comparator first fades and then turns on to avoid noise. The comparator then compares the power switch current with the COMP voltage, and when the sampling current is higher than the COMP voltage, the comparator output is low and the power MOSFET is turned off. Internal power The maximum current of the MOSFET is limited by internal cycles.

Startup and Shutdown

When VIN and EN are both above their respective thresholds, the chip starts working. The reference power supply section starts first, producing a steady reference voltage and current. An internal voltage regulator is then activated, which provides a stable voltage to the rest of the circuit. When the internal voltage reaches the upper rail, an internal timer keeps the power MOSFET 50 μ s off to prevent startup fluctuations. The internal soft start section kicks in, which keeps the SS output low to make sure the rest of the circuit is ready, then slowly ramps up.

Three conditions will turn off the chip: EN low, VIN low, and thermal shutdown. In the shutdown sequence, the signal path is blocked first to avoid any failure triggers. Then COMP voltage and internal power supply voltage drop. The floating drive is not subject to the shutdown command, but its charging path is disabled.

Application Circuits

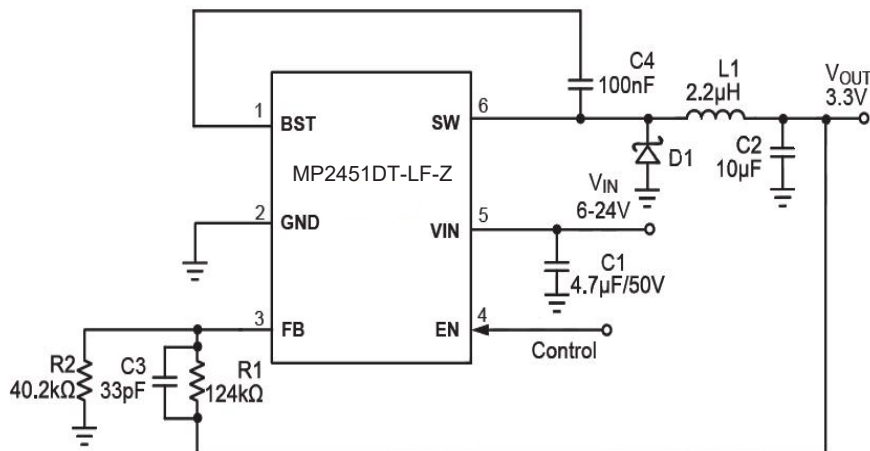

Recommend to use schottky diodes for D1, such as RB160M-60

3.3V output typical application circuit

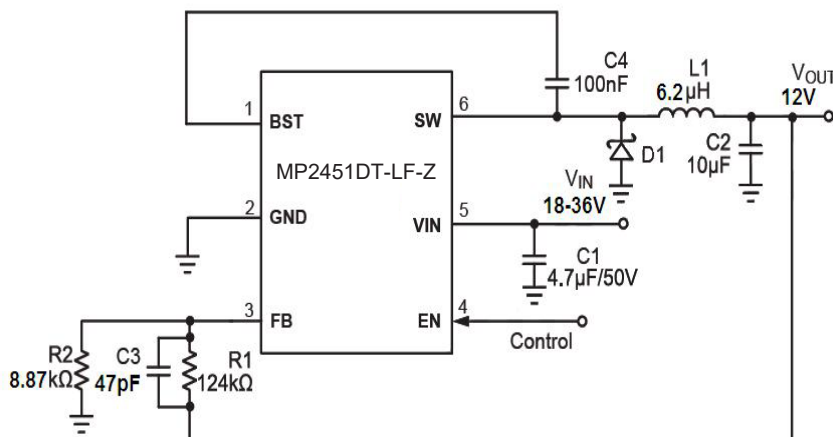

Recommend to use schottky diodes for D1, such as RB160M-60

12V output typical application circuit

PCB layout reference:

PCB layout is very important for the circuit to achieve stable operation. The following suggestions are for your reference:

1. Switching current path as short as possible, input capacitance, high-side MOSFET and external high-speed switching Schottky diode formed loop area as small as possible.
2. Bypass ceramic capacitor is placed near the VIN end.
3. All feedback circuit connections should be short and direct, with feedback resistance and compensation elements as close to the chip as possible.
4. SW route should be far away from sensitive simulated areas, such as FB.
5. SW, IN, and especially ground should be connected to a large copper-clad area to cool the chip, improve thermal performance, and enhance long-term reliability.

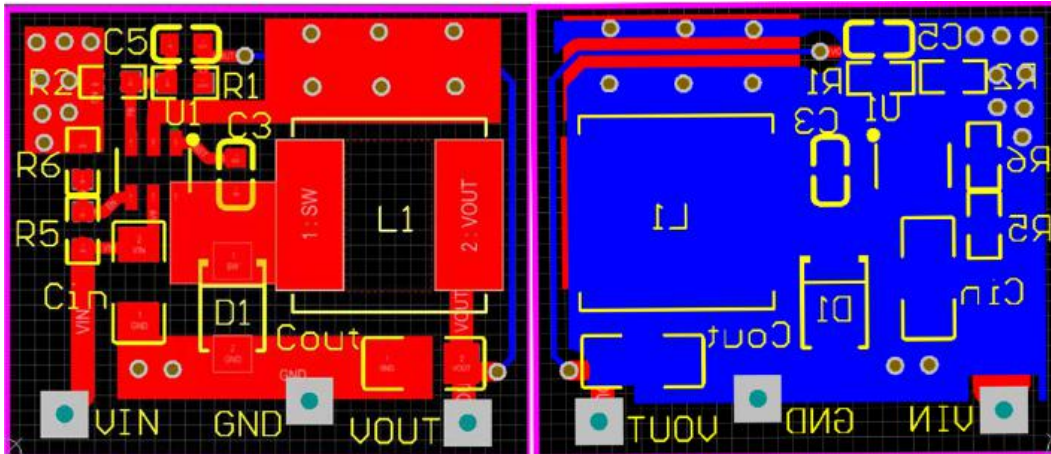

Application recommendation: Select components

Setting the Output Voltage

The output voltage is set using a resistive voltage divider from the output voltage to FB pin.
 $V_{FB} = V_{OUT} \cdot R2 / (R1 + R2)$

The feedback resistor R1 also sets the feedback loop bandwidth with the internal compensation capacitor. Choose R1 around 124kΩ for optimal transient response. Reference resistance for each output voltage:

Vout (V)	R1(KΩ)	R2(KΩ)
2.5	124 (1%)	57.7 (1%)
3.3	124 (1%)	40.2 (1%)
5	124 (1%)	23.4 (1%)
12	124 (1%)	8.87 (1%)

Inductor

The inductor is required to supply constant current to the output load. A larger value inductor will result in lower output ripple voltage. However, the volume will be larger, large series resistance and low saturation current.

Generally, a good rule for determining the inductance to use is to allow the peak-to-peak ripple current in the inductor to be approximately 30% of the maximum load current. Also, make sure that the peak inductor current is below the maximum switch current limit., it will not saturate at the maximum inductance peak. L1 can be calculated according to the following formula:

$$L1 = \frac{V_{OUT}}{f_s \times \Delta I_L} \times \left(1 - \frac{V_{OUT}}{V_{IN}} \right)$$

Input Capacitor

The input capacitor (C1) can be electrolytic, tantalum or ceramic. When using electrolytic or tantalum capacitors, a small, high quality ceramic capacitor, i.e. 0.1 μ F, should be placed as close to the IC as possible. When using ceramic capacitors, make sure they have sufficient capacitance values to prevent input from excessive voltage ripple.

Output Capacitor

The output capacitor (C2) is used to maintain the DC output voltage. Low ESR electrolytic capacitors are recommended to keep the output voltage ripple low. The characteristics of the output capacitor will affect the stability of the voltage stabilizer system.

Compensating components

The aim of the design is to formulate the transfer function of the converter to obtain an ideal loop gain. And achieve fast transient response and good stability.

Package Information (SOT23-6)

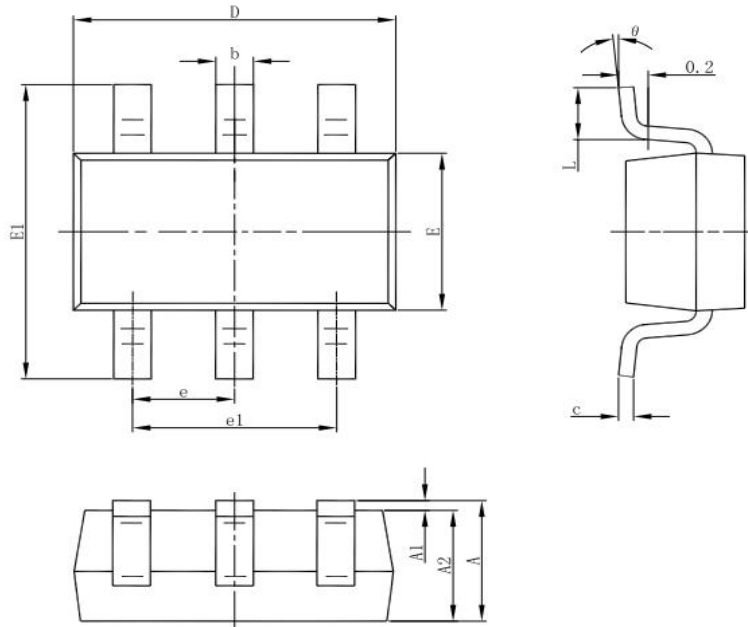

Symbol	Dimensions In Millimeters		Dimensions In Inches	
	Min.	Max.	Min.	Max.
A	1.050	1.250	0.041	0.049
A1	0.000	0.100	0.000	0.004
A2	1.050	1.150	0.041	0.045
b	0.300	0.500	0.012	0.020
c	0.100	0.200	0.004	0.008
D	2.820	3.020	0.111	0.119
E	1.500	1.700	0.059	0.067
E1	2.650	2.950	0.104	0.116
e	0.950(BSC)		0.037(BSC)	
e1	1.800	2.000	0.071	0.079
L	0.300	0.600	0.012	0.024
θ	0°	8°	0°	8°