



深圳市佑驰电子有限公司

Specification for Approval

产品名称: 一体系列电感

规格型号: HTMD-4020-XXX-M

产品编号: _____

日期: 2026-01-24

- 1、本承诺书的内容更改需经过双方确认，任何一方单独的修改均视为无效。
- 2、本承诺书在送达客户后，请给予承认并即签回，如无签回下订单的，我司有权以此承诺书标准生产，并表示购买方默认许可。

核准	审核	制作
	Aaron	Ada

High Current, Power Inductors

HTMD-4020-XXX-M Power Choke

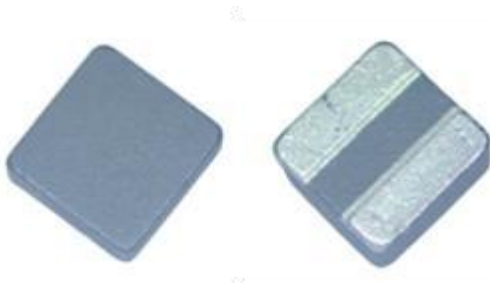

Description

- Halogen Free
- 125°C maximum total temperature operation
 - 4.3 x 4.3 x 2.0 mm maximum surface mount package
- Magnetically shielded, low EMI
- High current carrying capacity, Low core losses
- RoHS compliant

Applications

- Voltage Regulator Module (VRM)
- Multi-phase regulators
- Point-of-load modules
- Smart phone POL modules
- SSD modules
- Notebook regulators
- Battery power systems
- Graphics cards
- Data networking and storage systems

Environmental Data

- Storage temperature range: -55°C to +125 °C
- Operating temperature range: -55°C to +125°C (ambient plus self-temperature rise)
- Solder reflow temperature: J-STD-020 compliant

Description			
HTMD-4020-3R3-M	3.3 μH	±20 %	
Model	Inductance Value	Inductance Tolerance	
Global Part Number			
H T M D	4 0 2 0	3 R 3	M
Product Series	Dimensions	Inductance Value	Tolerance

Part No.	Inductance	DC Resistance		Heating Rating Current		Saturation Current	
	L0 (μH)	DCR (mΩ)		Idc (A)		Isat (A)	
	±20 %, 100kHz, 1V	TYP.	MAX.	TYP.	MAX.	TYP.	MAX.
HTMD-4020-R22-M	0.22	8	12	9.5	8.6	11.0	10.0
HTMD-4020-R47-M	0.47	16	22	8.5	7.7	10.0	9.0
HTMD-4020-1R0-M	1.00	29	38	8.0	7.0	9.5	8.5
HTMD-4020-1R5-M	1.50	35	46	7.8	7.3	8.5	8.0
HTMD-4020-2R2-M	2.20	40	52	6.8	6.3	7.3	6.8
HTMD-4020-3R3-M	3.30	65	80	6.3	5.8	6.7	6.2
HTMD-4020-4R7-M	4.70	75	98	5.8	5.3	6.3	5.8
HTMD-4020-6R8-M	6.80	130	155	4.7	4.2	5.5	5.0
HTMD-4020-8R2-M	8.20	198	225	4.1	3.7	4.5	4.0
HTMD-4020-100-M	10.0	230	260	3.8	3.2	4.0	3.5

Notes

1. All test data is referenced to 25 °C ambient
2. Operating temperature range - 55 °C to + 125 °C
3. Idc(A):DC current (A) that will cause an approximate ΔT of 40 °C(reference ambient temperature is 25 °C)
4. Isat(A): DC current (A) that will cause L0 to drop approximately 30%
5. The part temperature (ambient + temp rise) should not exceed 125 °C under worst case operating conditions. Circuit design, component placement, PWB trace size and thickness, airflow and other cooling provisions all affect the part temperature. Part temperature should be verified in the end application.

•Dimensions-mm

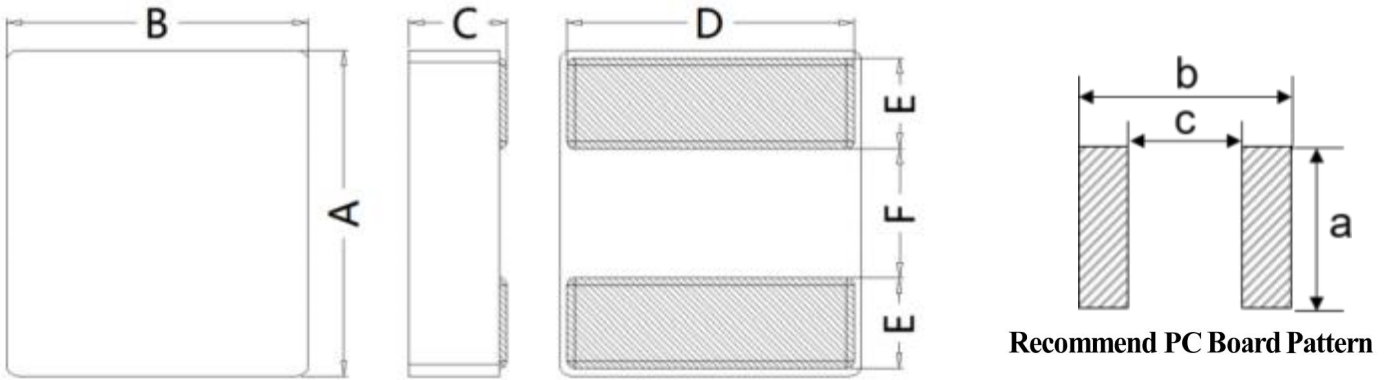

Type	A	B	C	E	F	a	b	c
HTMD-4020	4.0±0.3	4.0±0.3	2.00Max.	1.10±0.2	1.9±0.3	4.6Typ.	5.0Typ.	1.4Typ.

Notes

1. Tolerances are +/-0.1 millimeters unless stated otherwise
2. Dimensions of recommended PCB layout are reference only.
3. Do not route traces nor place vias underneath the inductor. Proper layout is required.

•Marking

1. Marking :Ink Marking
2. Stamping 3R3 :inductor

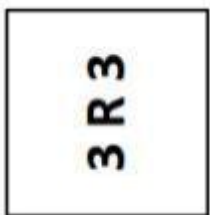

Tape Packaging Dimensions

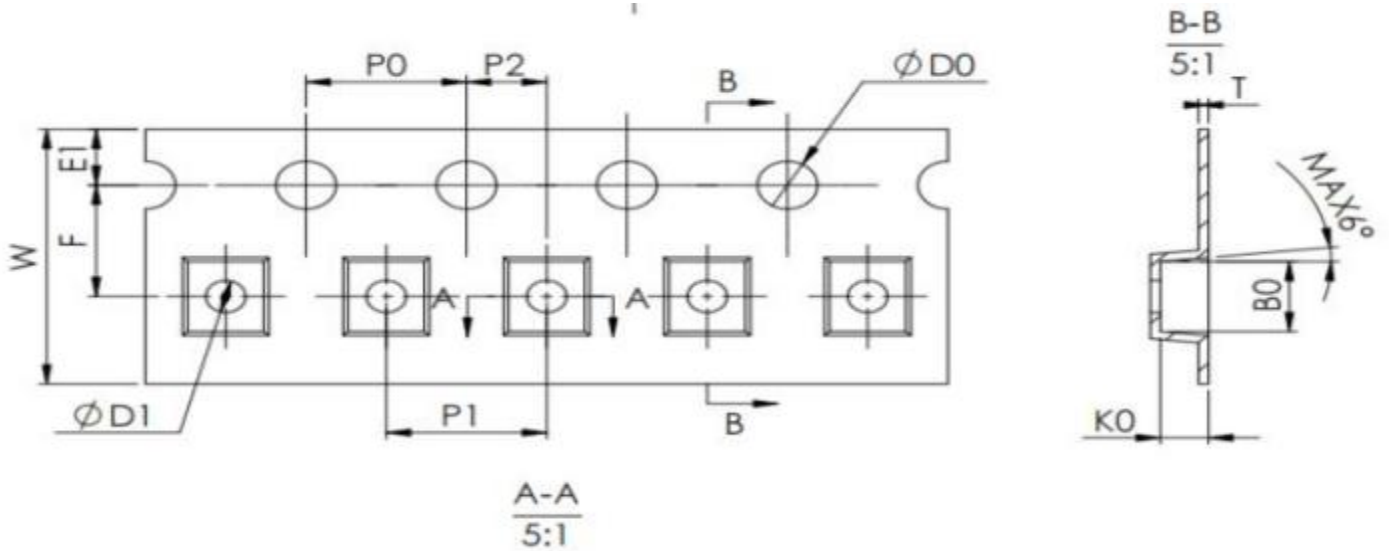

A0

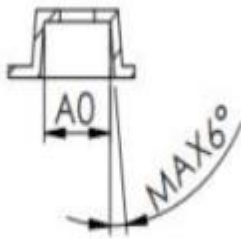

Reel Dimensions

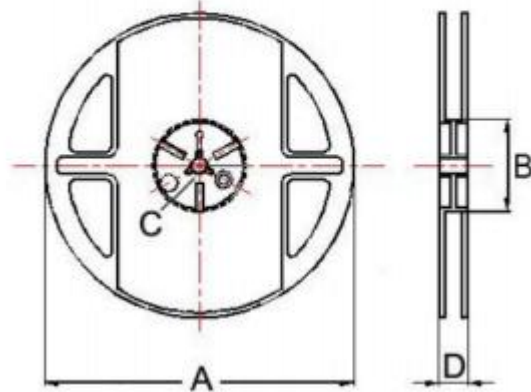

Tape Dimensions (mm)							Reel Dimensions (mm)			
A0	B0	K0	T	W	P0	D0	A	B	C	D
4.35±0.1	4.35±0.1	2.2±0.10	0.35±0.05	12±0.1	4±0.1	1.5±0.1	330	100	13.2	18.3

REFLOW PROFILE

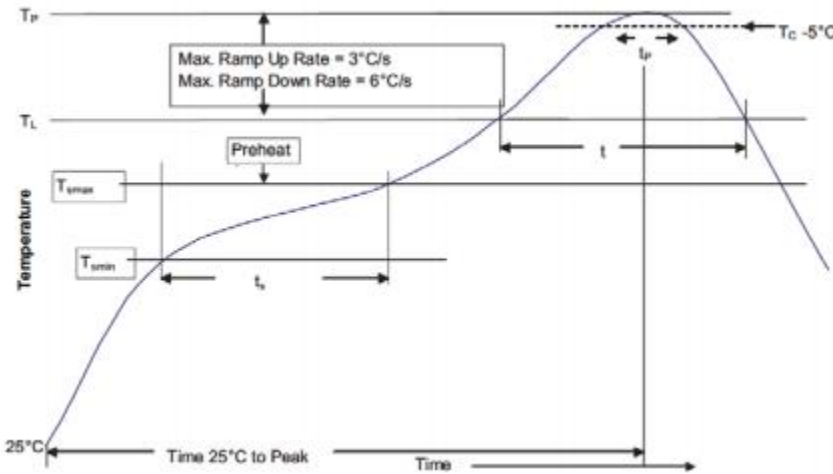

Table 1 - Standard SnPb Solder (T_C)

Package Thickness	Volume mm ³ <350	Volume mm ³ ≥350
<2.5mm	235°C	220°C
≥2.5mm	220°C	220°C

Table 2 - Lead (Pb) Free Solder (T_C)

Package Thickness	Volume mm ³ <350	Volume mm ³ 350 - 2000	Volume mm ³ >2000
<1.6mm	260°C	260°C	260°C
1.6 - 2.5mm	260°C	250°C	245°C
>2.5mm	250°C	245°C	245°C

Reference JDEC J-STD-020

Profile Feature	Standard SnPb Solder	Lead (Pb) Free Solder
Preheat and Soak		
• Temperature min. (T_{smin})	100°C	150°C
• Temperature max. (T_{smax})	150°C	200°C
• Time (T_{smin} to T_{smax}) (t_s)	60-120 Seconds	60-120 Seconds
Average ramp up rate T_{smax} to T_p	3°C/ Second Max.	3°C/ Second Max.
Liquidous temperature (T_L)	183°C	217°C
Time at liquidous (t_L)	60-150 Seconds	60-150 Seconds
Peak package body temperature (T_p)*	Table 1	Table 2
Time (t_p)** within 5 °C of the specified classification temperature (T_C)	20 Seconds**	30 Seconds**
Average ramp-down rate (T_p to T_{smax})	6°C/ Second Max.	6°C/ Second Max.
Time 25°C to Peak Temperature	6 Minutes Max.	8 Minutes Max.

* Tolerance for peak profile temperature (T_p) is defined as a supplier minimum and a user maximum.

** Tolerance for time at peak profile temperature (t_p) is defined as a supplier minimum and a user maximum.

包装数量 Packing quantity

Series	卷盘REEL (PCS)
HTMD-0420	3000

注：包装载带前/后预留空载带长度。载带前端预留：20个单元格，
载带后端预留：20个单元格。

