

修 订 REV NO	标 记 MARK	修 改 描 要 REVISION DESCRIPTION	签 名 SIGNATURE	日 期 DATE
		NEW DWG		2016-03-12

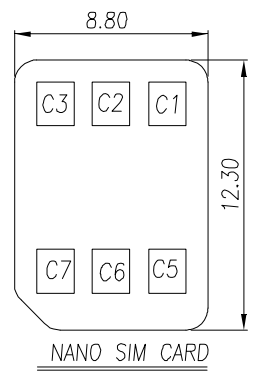
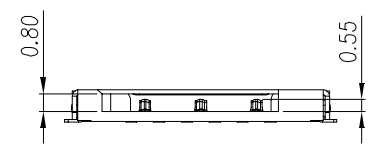
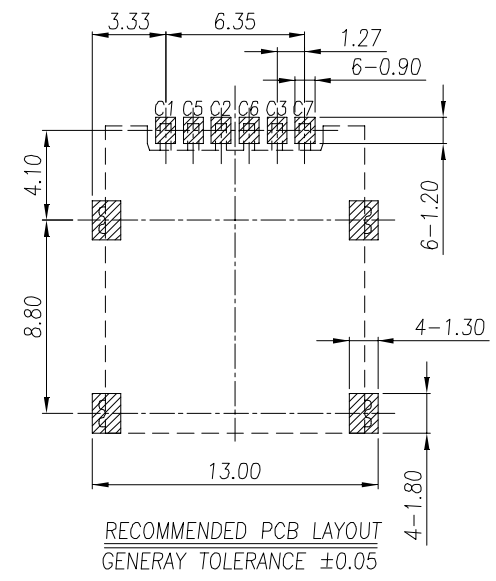
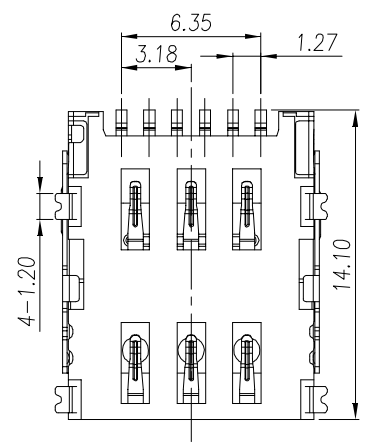
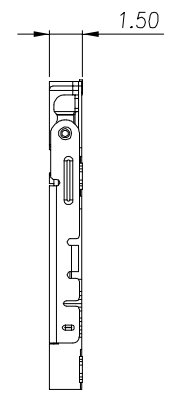
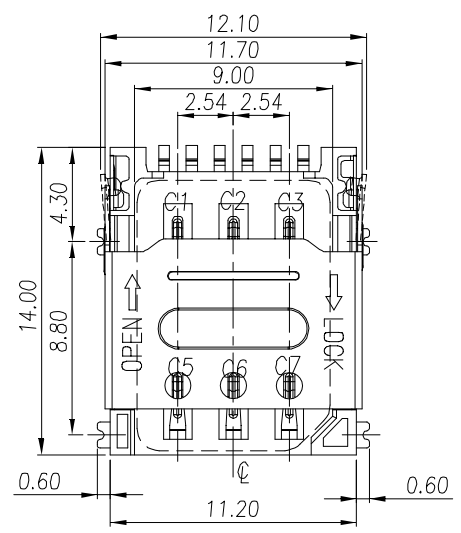

SIM CARD	
Pin No.	NAME
C1	VCC
C2	RST
C3	CLK
C5	GND
C6	VPP
C7	I/O

NOTES:

- ELECTRICAL CHARACTERISTICS
  - CONTACT RESISTANCE: 60 Milliohms Max
  - INSULATION RESISTANCE: 1,000 Megohms Min.
  - DIELECTRIC WITHSTANDING VOLTAGE: 500V AC FOR 1 MINUTE.
- MECHANICAL CHARACTERISTICS
  - OPERATION TEMPERATURE RANGE: -25°C~+70°C
  - DURABILITY: 5000 CYCLES
- MATERIAL:
  - HOUSING: THERMOPLASTIC,UL 94-V0
  - TERMINAL: COPPER ALLOY,T=0.15
  - SHELL: STAINLESS STEEL,T=0.15
- FINISHED:
  - TERMINAL: Ni PLATED UNDER,Au PLATED ON CONTACT AREA,G/F PLATED ON SOLDERTAIL
  - SHELL: Ni PLATED UNDER,G/F PLATED ON SOLDERTAIL

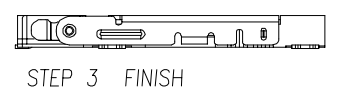
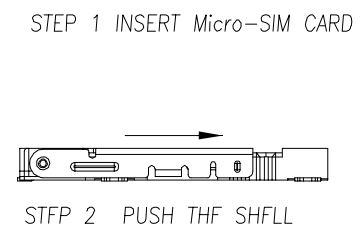
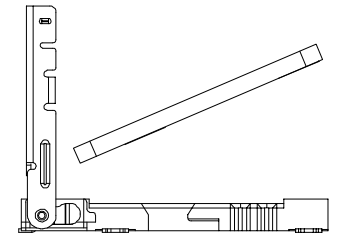



深圳市华德共创科技有限公司  
Shenzhen Huade co-create Technology Co.,LTD  
电话: 0755-27111216 传真: 0755-29940187

-TOLERANCES- UNLESS OTHERWISE SPECIFIED 公差参数表		 	TITLE: 产品名称: NANO 掀盖式卡座 1.5H					
X.X	±0.30	X.X*	±3°	APPD: 核准:	PART NO: 产品编号: K-DYX-009			
X.XX	±0.20	X.XX*	±2°	CHECK: 校对: 王建业	DATE	SCALE	UNIT	CODE NUMBER
X.XXX	±0.10	X.XXX*	±1°	DRAW: 绘图: 黄艳兰	2016-03-12	1:1	mm	A001