

修 订	标 记	修 改 描 述	签 名	日 期
REV NO	MARK	REVISION DESCRIPTION	SIGNATURE	DATE
		NEW DWG		2016-03-12

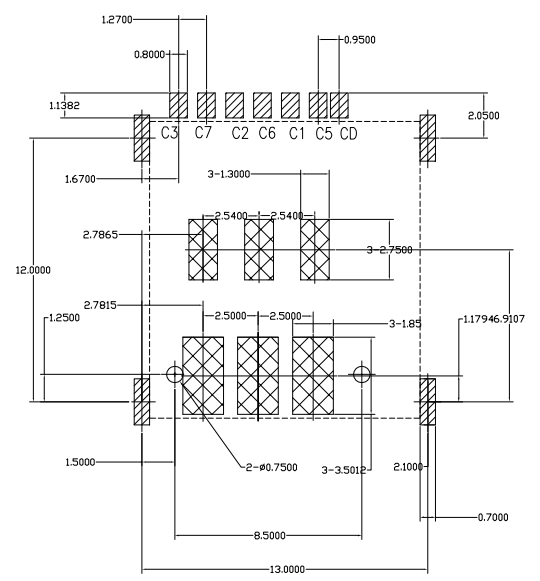

RECOMMENDED PCB LAYOUT
GENERAL TOLERANCE ± 0.05

▨ PAD
▩ KEEP OUT AREA

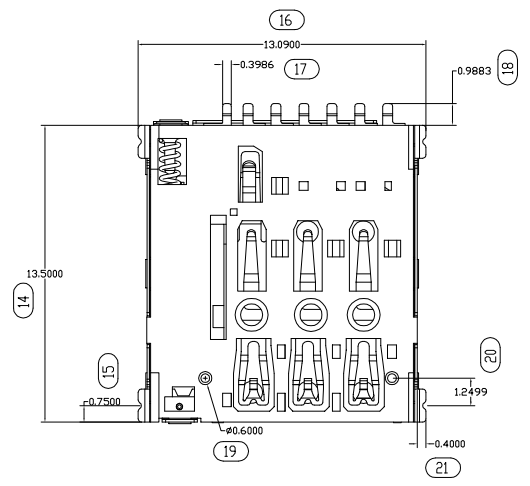
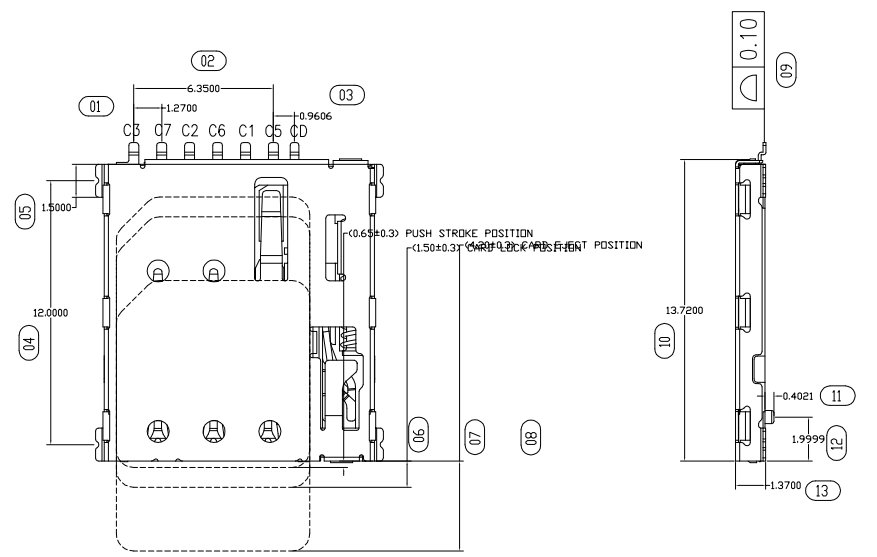
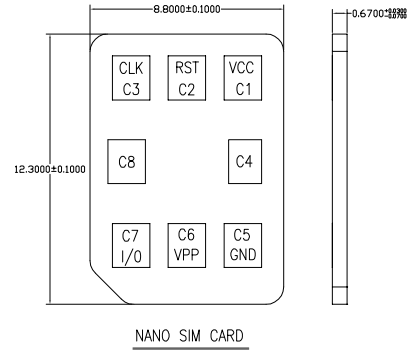

NOTES:

- MATERIAL:
HOUSING:HI-TEMP. PLASIC UL 94V-0
CONTACT:COPPER ALLOY
SHELL:STANLESS STEEL
- PLATING :
TERMINAL:
CONTACT AREA: Au GOLD FLASH.
SOLDER AREA: AU GOLD FLASH.
UNDER PLATE: NICKEL.
SHELL: NICKEL PLATED OVER ALL.
SOLDER AREA: GOLD FLASH.
- SPECIALITY:
3.1 Rated current:1.0A
3.2 Rated voltage:30V
3.3 Contact Resistance:100mΩ MAX
3.4 Insulation Resistance:1000MΩ MIN 500V DC
3.5 Dielectric withstanding voltage: 500V AC.
3.6 Solder ability:260+0/-5℃, 30±10s.
3.7 Durability:5000 Cycles Min.
3.8 Operating condition:Temperature-40℃~+85℃,
Humidity 80% R.H MAX

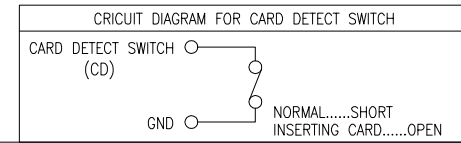

HDC		深圳市华德共创科技有限公司 Shenzhen Huade co-create Technology Co.,LTD 电话：0755-27111216 传真：0755-29940187						
-TOLERANCES- UNLESS OTHERWISE SPECIFIED 公差参数表				TITLE: 产品名称: NANO 自弹 SIM卡 1.37H二代				
X.X	± 0.30	X.X*	$\pm 3^\circ$	APPD: 核准:	PART NO: 产品编号: K-DYX-007			
X.XX	± 0.20	X.XX*	$\pm 2^\circ$	CHECK: 校对: 王建业	DATE	SCALE	UNIT	CODE NUMBER
X.XXX	± 0.10	X.XXX*	$\pm 1^\circ$	DRAW: 绘图: 黄艳兰	2016-03-12	1:1	mm	A001

修改		标记	修改摘要	签名	日期
REV	NO	MARK	REVISION DESCRIPTION	SIGNATURE	DATE
			NEW DRG		2016-03-12

客户拉出方向

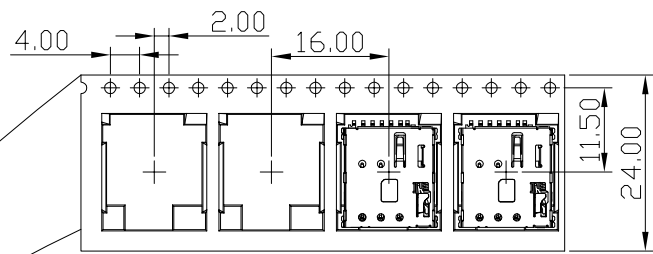

客户拉出方向

自粘上贴

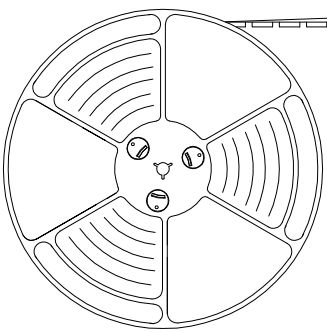

NOTES

- 每卷包装数量:1500PCS/每卷
- 卷带包装方式:
 - 空15PCS
 - 产品1500PCS
 - 空15PCS
 - 尾部 240mm
 - 产品放置区
 - 轴心段空240mm
- 每箱包装数量:1500PCS/箱
- 纸箱350mm*350mm*340mm(内部尺寸), 材质K=K

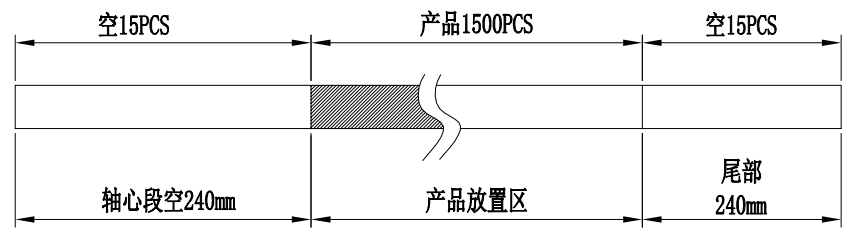

PE袋

纸箱底部和顶部各垫一块珍珠棉

护角

纸箱

封箱胶带"工"字形封好

绿色环保标签 RoHS

产品标签贴在纸箱左上角

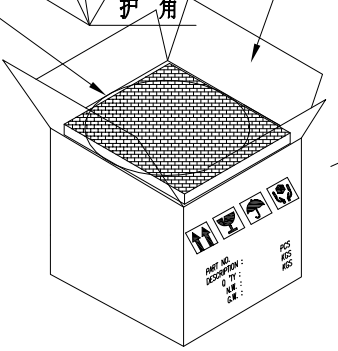
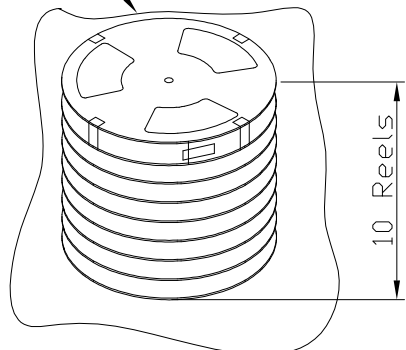

将10卷产品放入箱内

		深圳市华德共创科技有限公司 Shenzhen Huade co-create Technology Co.,LTD 电话: 0755-27111216 传真: 0755-29940187						
		-TOLERANCES- UNLESS OTHERWISE SPECIFIED 公差参数表		TITLE: 产品名称: NANO 自弹 SIM卡 1.37H二代				
X.X	± 0.30	X.X*	$\pm 3^{\circ}$	APPD: 核准:	PART NO: 产品编号: K-DYX-007			
X.XX	± 0.20	X.XX*	$\pm 2^{\circ}$	CHECK: 校对: 王建业	DATE	SCALE	UNIT	CODE NUMBER
X.XXX	± 0.10	X.XXX*	$\pm 1^{\circ}$	DRAW: 绘图: 黄艳兰	2016-03-12	1:1	mm	A001