

Description:

This Dual P-Channel MOSFET uses advanced trench technology and design to provide excellent $R_{DS(on)}$ with low gate charge.

It can be used in a wide variety of applications.

Features:

- 1) $V_{DS}=-20V, I_D=-3A, R_{DS(ON)}<55m\ \Omega @V_{GS}=-4.5V$ (Typ: $43m\ \Omega$)
- 2) Low gate charge.
- 3) Green device available.
- 4) Advanced high cell density trench technology for ultra low $R_{DS(ON)}$.
- 5) Excellent package for good heat dissipation.
- 6) MSL3

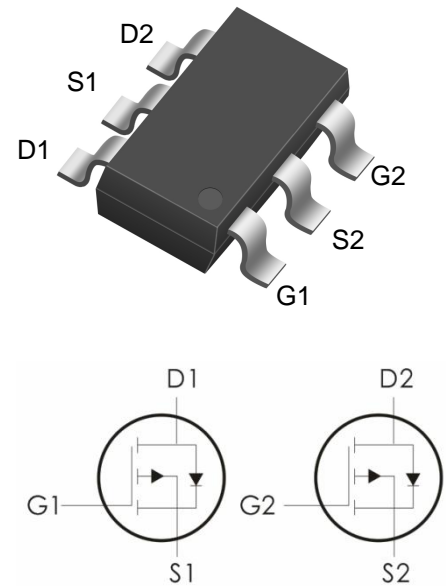

Package Marking and Ordering Information:

Part NO.	Marking	Package	Packing
DO2301BD	2301B	SOT-23-6D	3000 pcs/Reel

Absolute Maximum Ratings: ($T_A=25^\circ\text{C}$ unless otherwise noted)

Symbol	Parameter	Ratings	Units
V_{DS}	Drain-Source Voltage	-20	V
V_{GS}	Gate-Source Voltage	± 12	V
I_D	Continuous Drain Current	-3	A
I_{DM}	Pulsed Drain Current ¹	-10	
P_D	Power Dissipation	1	W
T_J, T_{STG}	Operating and Storage Junction Temperature Range	-55-+150	$^\circ\text{C}$

Thermal Characteristics:

Symbol	Parameter	Max	Units
$R_{\theta JA}$	Thermal Resistance, Junction to Ambient	125	$^\circ\text{C}/\text{W}$

Electrical Characteristics: ($T_A=25^\circ\text{C}$ unless otherwise noted)

Symbol	Parameter	Conditions	Min	Typ	Max	Units
Off Characteristics						
BV_{DSS}	Drain-Source Breakdown Voltage	$V_{GS}=0V, I_D=250\ \mu\text{A}$	-20	---	---	V
I_{DSS}	Zero Gate Voltage Drain Current	$V_{GS}=0V, V_{DS}=-20V$	---	---	-1	μA
I_{GSS}	Gate-Source Leakage Current	$V_{GS}=\pm 12V, V_{DS}=0A$	---	---	± 100	nA
On Characteristics						
$V_{GS(th)}$	Gate-Source Threshold Voltage	$V_{GS}=V_{DS}, I_D=250\ \mu\text{A}$	-0.4	-0.7	-1	V
$R_{DS(on)}$	Drain-Source On Resistance ²	$V_{GS}=-4.5V, I_D=-3A$	---	43	55	$\text{m}\Omega$
		$V_{GS}=-2.5V, I_D=-3A$	---	54	70	$\text{m}\Omega$
Dynamic Characteristics						
C_{iss}	Input Capacitance	$V_{DS}=-10V, V_{GS}=0V, f=1\text{MHz}$	---	480	---	pF
C_{oss}	Output Capacitance		---	83	--	
C_{rss}	Reverse Transfer Capacitance		---	54	---	
Switching Characteristics						
$t_{d(on)}$	Turn-On Delay Time	$V_{DS}=-10V, I_D=-1A,$ $R_{ENG}=6\ \Omega, V_{GS}=-4.5V$	---	11	---	ns
t_r	Rise Time		---	52	---	ns
$t_{d(off)}$	Turn-Off Delay Time		---	17	---	ns
t_f	Fall Time		---	10	---	ns
Q_g	Total Gate Charge		---	4	---	nC
Q_{gs}	Gate-Source Charge	$V_{GS}=-4.5V, V_{DS}=-10V,$	---	0.7	---	nC
Q_{gd}	Gate-Drain "Miller" Charge	$I_D=-3A$	---	1.2	---	nC
Drain-Source Diode Characteristics						
V_{SD}	Diode Forward Voltage	$V_{GS}=0V, I_{SD}=-3A$	---	---	-1.2	V
I_S	Continuous Drain Current	$V_D=V_G=0V$	---	---	-3	A
I_{SM}	Pulsed Drain Current		---	---	-10	A

Notes:

1. Repetitive Rating: Pulse Width Limited by Maximum Junction Temperature
2. Pulse Test: Pulse Width $\leq 300\mu\text{s}$, Duty Cycle $\leq 0.5\%$

Typical Characteristics: ($T_A=25^\circ\text{C}$ unless otherwise noted)

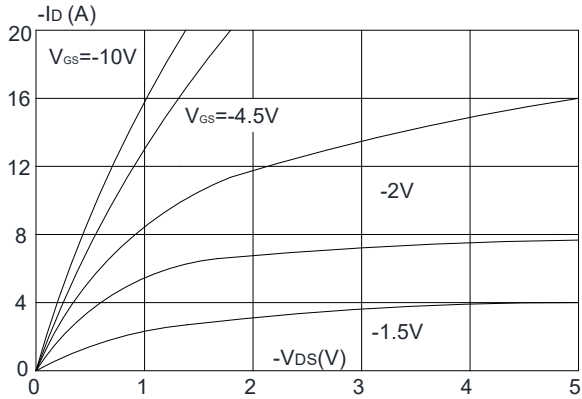

Figure 1: Output Characteristics

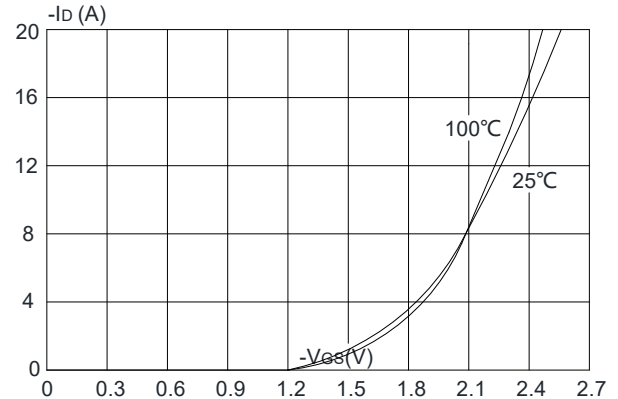

Figure 2: Typical Transfer Characteristics

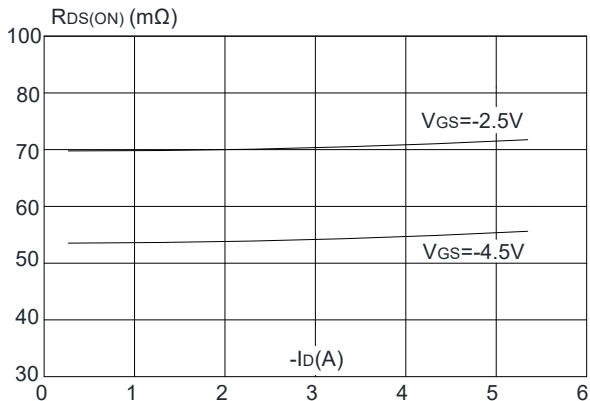

Figure 3: On-resistance vs. Drain Current

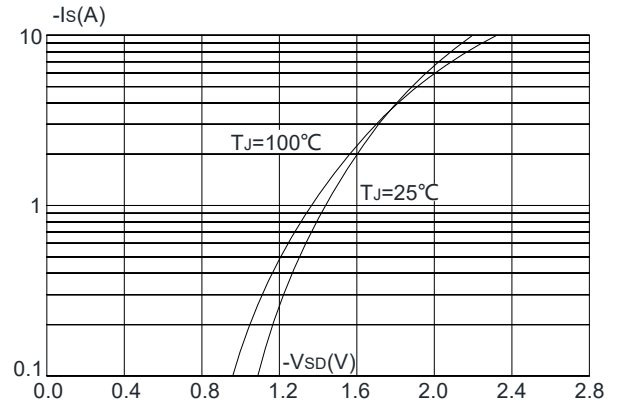

Figure 4: Body Diode Characteristics

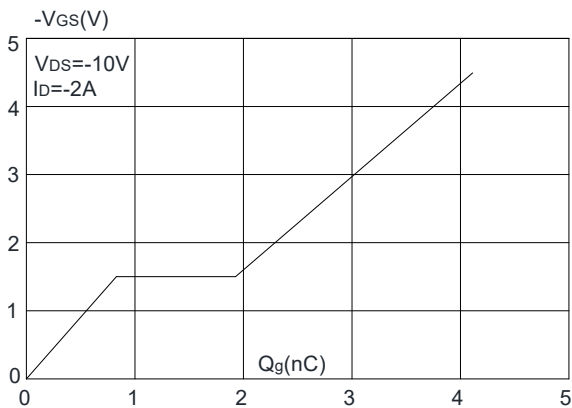

Figure 5: Gate Charge Characteristics

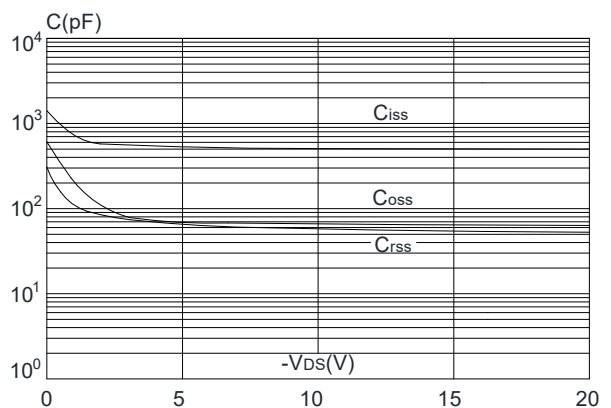

Figure 6: Capacitance Characteristics

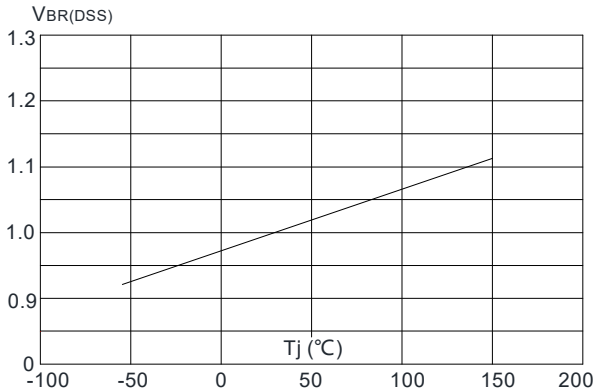

Figure 7: Normalized Breakdown Voltage vs. Junction Temperature

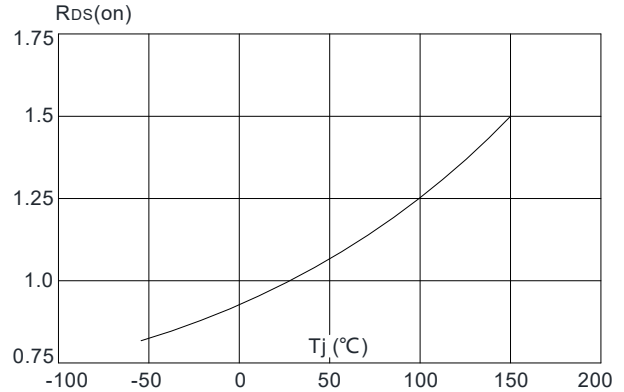

Figure 8: Normalized on Resistance vs. Junction Temperature

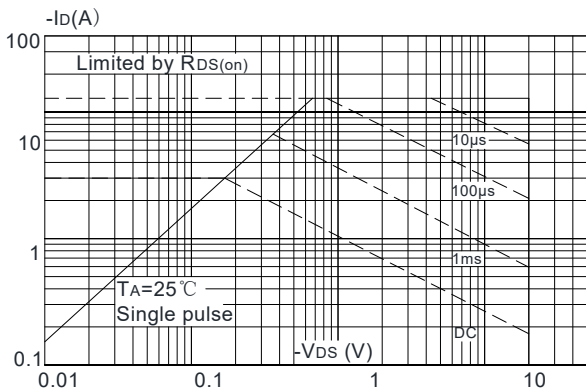

Figure 9: Maximum Safe Operating Area

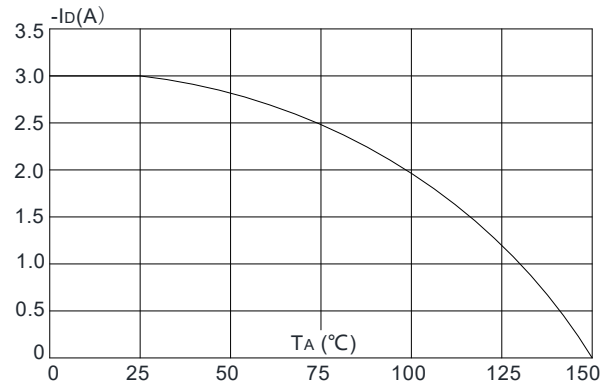

Figure 10: Maximum Continuous Drain Current vs. Ambient Temperature

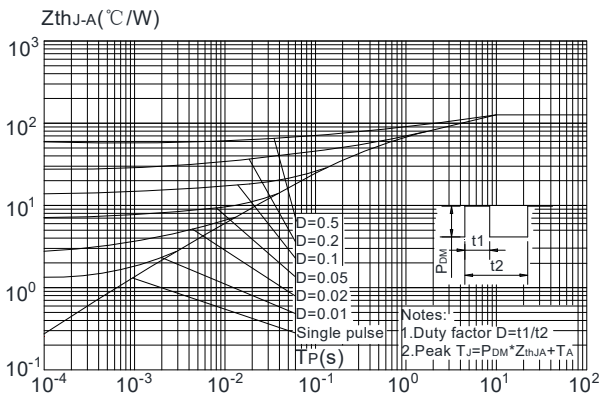
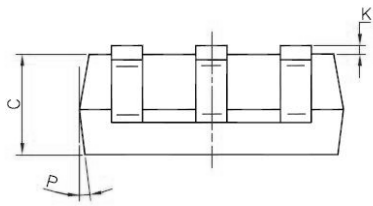
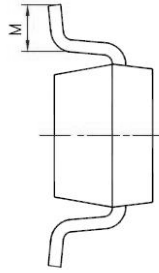
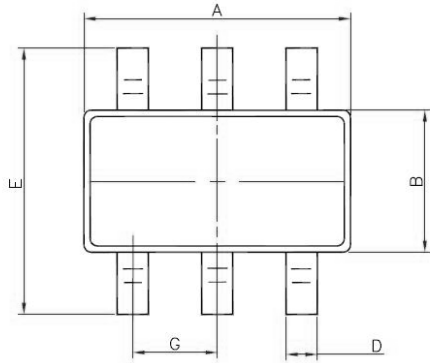

Figure.11: Maximum Effective Transient Thermal Impedance, Junction-to-Ambient

SOT-23-6 Package Outline Data



DIM	MILLIMETERS
A	2.82~3.02
B	1.60 ± 0.10
C	1.10 ± 0.05
D	0.40 ± 0.10
E	2.65~2.95
G	0.95typ
K	0.00~0.10
M	0.20MIN
P	9 ± 2°

UNIT: mm

Tape & Reel Information

Dimensions in mm

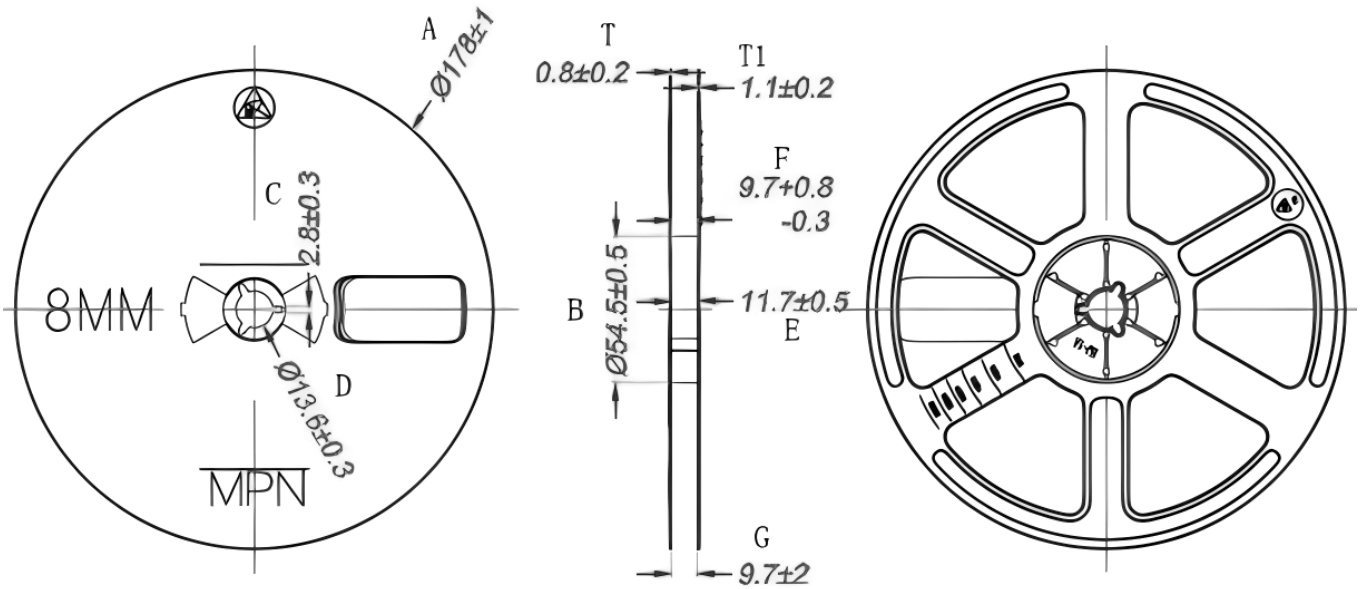

PKG TYPE	W	P	E	F	D	D1	Po	Po10	P2	A0	B0	K0	T
SOT23-3	8.00	4.00	1.75	3.50	1.50	1.00	4.00	40.00	2.00	3.13	3.22	1.30	0.20
Tolerance	± 0.2	± 0.1	± 0.1	± 0.1	± 0.1	± 0.1	± 0.1	± 0.2	± 0.1	± 0.1	± 0.1	± 0.1	± 0.03

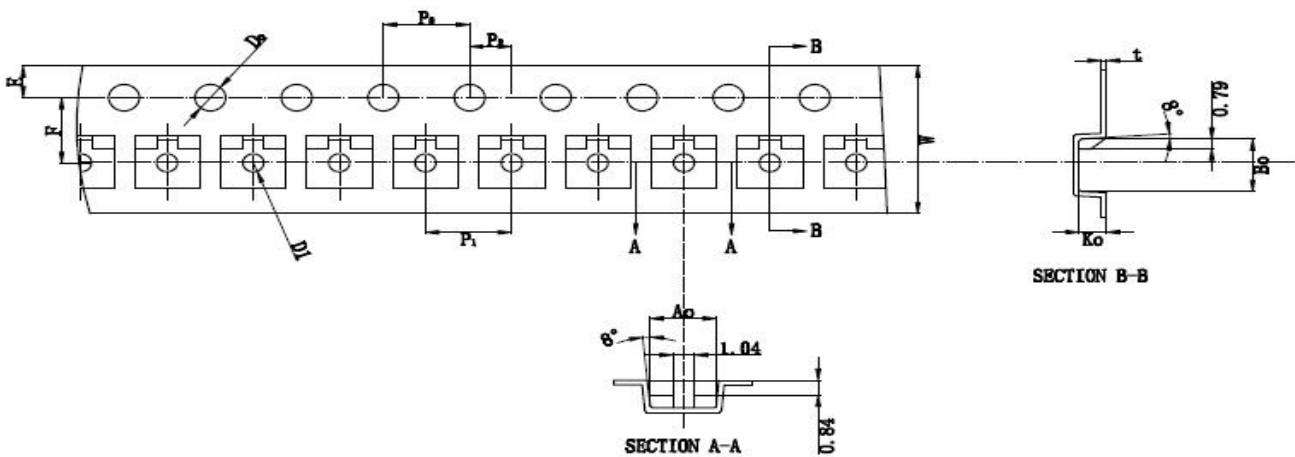

Pulling direction 

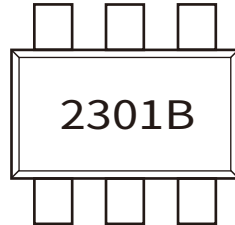
Marking Information:**Previous Version**

Version	Date	Subjects (major changes since last revision)
1.0	2024-10-18	Release of final version

Attention :

- Information furnished in this document is believed to be accurate and reliable. However, Shenzhen Doingter Semiconductor Co.,Ltd. assumes no responsibility for the consequences of use without consideration for such information nor use beyond it.
 - Information mentioned in this document is subject to change without notice, apart from that when an agreement is signed, Shenzhen Doingter complies with the agreement. Products and information provided in this document have no infringement of patents.
 - Shenzhen Doingter assumes no responsibility for any infringement of other rights of third parties which may result from the use of such products and information. This document supersedes and replaces all information previously supplied.
-  Is a registered trademark of Shenzhen Doingter Semiconductor Co., Ltd. Copyright © 2013 Shenzhen Doingter Semiconductor Co.,Ltd. Printed All rights reserved.