

### General Description

The TC7SH125 is a single bus buffer gate. The device is designed for 2 V to 5.5 V for  $V_{CC}$  operation, it can be driven from either 3.3 V or 5 V devices. This feature allows the use of these devices as translators in mixed 3.3 V and 5 V environments.

The TC7SH125 device is a single line driver with a 3-state output. The output is disabled when the output-enable ( $\overline{OE}$ ) input is high. The CMOS device has high output drive while maintaining low static power dissipation over a broad  $V_{CC}$  operating range.

The TC7SH125 is available in SOT23-5 and SOT353 packages.

### Features

- ◆ Wide Supply Voltage Range : 2 V to 5.5 V
- ◆ Max.  $T_{PD}$  of 4.5 ns at  $V_{CC} = 3.3$  V
- ◆ Low Power Consumption, 10  $\mu$ A (Max.  $I_{CC}$ )
- ◆  $\pm 24$  mA Output Drive at  $V_{CC} = 3.3$  V
- ◆ Latch-Up Performance Exceeds 100 mA Per JESD 78, Class II
- ◆ ESD Protection Exceeds JESD 22
  - 2000 V Human-Body Model (A114-A)
  - 1000 V Charged-Device Model (C101)
- ◆ Operating temperature Range :  $-40^{\circ}\text{C}$  to  $125^{\circ}\text{C}$
- ◆ Available Package : SOT23-5 and SOT353

### Applications

- ◆ Active Noise Cancellation (ANC)
- ◆ Blood Pressure Monitor
- ◆ Embedded PC
- ◆ Solid State Drive (SSD) : Client and Enterprise
- ◆ TV : LCD/Digital and High-Definition (HDTV)
- ◆ Tablet : Enterprise
- ◆ Video Analytics : Server
- ◆ Wireless Headset, Keyboard, and Mouse
- ◆ Power Supply : Telecom/Server AC/DC Controller

### Logic Diagram

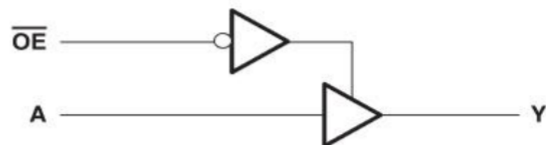

### Ordering Information

ORDER NUMBER	PACKAGE DESCRIPTION	PACKAGE OPTION
TC7SH125F-TP	SOT23-5	Tape and Reel,3000
TC7SH125FU-TP	SOT353	Tape and Reel,3000

### Pin Configuratio

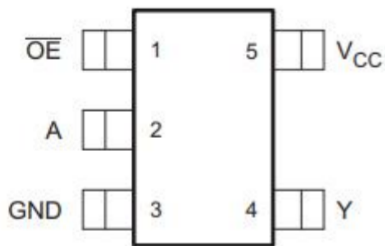

SOT23-5 and SOT353 (Top View)

### Function Table(each gate)

INPUTs		OUTPUT
$\overline{OE}$	B	Y
L	L	L
L	H	H
H	X	Z

*H = HIGH voltage level; L = LOW voltage level; Z = High impedance*

### Pin Description

Pin		Function
Num	Name	
1	$\overline{OE}$	Output Enable Input
2	A	Data Input
3	GND	Ground
4	Y	Data Output
5	Vcc	Supply Power Input

### Absolute Maximum Ratings

Over operating free-air temperature range (unless otherwise noted) <sup>(1)</sup>

Parameter	Symbol	Value	Units
Supply Voltage	$V_{CC}$	-0.5 to 6.5	V
Input Voltage	$V_I$	-0.5 to 6.5	V
Voltage range applied to any output in the high-impedance or power-off state <sup>(2)</sup>	$V_O$	-0.5 to 6.5	V
Voltage range applied to any output in the high or low state <sup>(2)(3)</sup>	$V_O$	-0.5 to $V_{CC}+0.5$	V
Input clamp current, $V_I < 0$	$I_{IK}$	-50	mA
Output clamp current, $V_O < 0$	$I_{OK}$	-50	mA
Continuous output current	$I_O$	$\pm 50$	mA
Storage temperature range	$T_{STG}$	-65 to 150	°C
ESD HBM, ANSI/ESDA/JEDEC JS-001 <sup>(4)</sup>	$ESD_{HBM}$	$\pm 2000$	V
ESD CDM, JESD22-C101 <sup>(5)</sup>	$ESD_{CDM}$	$\pm 1000$	V

(1) Stresses beyond those listed under absolute maximum ratings may cause permanent damage to the device. These are stress ratings only, and functional operation of the device at these or any other conditions beyond those indicated under recommended operating conditions is not implied. Exposure to absolute-maximum-rated conditions for extended periods may affect device reliability.

(2) The input and output negative-voltage ratings may be exceeded if the input and output current ratings are observed.

(3) The value of  $V_{CC}$  is provided in the Recommended Operating Conditions table.

(4) JEDEC document JEP155 states that 500-V HBM allows safe manufacturing with a standard ESD control process.

(5) JEDEC document JEP157 states that 250-V CDM allows safe manufacturing with a standard ESD control process.

### Recommended Operating Conditions

Parameter	Symbol	Test Conditions	Min	Typ	Max	Units
Supply voltage	$V_{CC}$	Operating	2		5.5	V
		Data retention only	2			
Input voltage	$V_I$		0		5.5	V
Output voltage	$V_O$				$V_{CC}$	V
High-level input voltage	$V_{IH}$	$V_{CC} = 2\text{ V}$	$0.65 \times V_{CC}$			V
		$V_{CC} = 2.3\text{ V to }2.7\text{ V}$	1.7			
		$V_{CC} = 3\text{ V to }3.6\text{ V}$	2			
		$V_{CC} = 4.5\text{ V to }5.5\text{ V}$	$0.7 \times V_{CC}$			
Low-level input voltage	$V_{IL}$	$V_{CC} = 2\text{ V}$			$0.35 \times V_{CC}$	V
		$V_{CC} = 2.3\text{ V to }2.7\text{ V}$			0.7	
		$V_{CC} = 3\text{ V to }3.6\text{ V}$			0.8	
		$V_{CC} = 4.5\text{ V to }5.5\text{ V}$			$0.3 \times V_{CC}$	
High-level output current	$I_{OH}$	$V_{CC} = 2\text{ V}$			-4	mA
		$V_{CC} = 2.3\text{ V}$			-8	
		$V_{CC} = 3\text{ V}$			-16	
		$V_{CC} = 3\text{ V}$			-24	
		$V_{CC} = 4.5\text{ V}$			-32	
Low-level output current	$I_{OL}$	$V_{CC} = 2\text{ V}$			4	mA
		$V_{CC} = 2.3\text{ V}$			8	
		$V_{CC} = 3\text{ V}$			16	
		$V_{CC} = 3\text{ V}$			24	
		$V_{CC} = 4.5\text{ V}$			32	
Input transition rise or fall rate	$\Delta T/\Delta V$	$V_{CC} = 2\text{ V}$			20	ns/V
		$V_{CC} = 3.3\text{ V} \pm 0.3\text{ V}$			10	
		$V_{CC} = 5\text{ V} \pm 0.5\text{ V}$			5	
Operating temperature	$T_A$		-40		125	°C

### Electrical Characteristics

Parameter	Symbol	Test Conditions	Min	Typ	Max	Units
High-level output voltage	$V_{OH}$	$V_{CC} = 2\text{ V to } 5.5\text{ V}, I_{OH} = -100\ \mu\text{A}$	$V_{CC}-0.1$			V
		$V_{CC} = 2\text{ V}, I_{OH} = -4\text{ mA}$	1.2			
		$V_{CC} = 2.3\text{ V}, I_{OH} = -8\text{ mA}$	1.9			
		$V_{CC} = 3\text{ V}, I_{OH} = -16\text{ mA}$	2.4			
		$V_{CC} = 3\text{ V}, I_{OH} = -24\text{ mA}$	2.3			
		$V_{CC} = 4.5\text{ V}, I_{OH} = -32\text{ mA}$	3.8			
Low-level output voltage	$V_{OL}$	$V_{CC} = 2\sim 5.5\text{ V}, I_{OL} = 100\ \mu\text{A}$			0.1	V
		$V_{CC} = 2\text{ V}, I_{OL} = 4\text{ mA}$			0.45	
		$V_{CC} = 2.3\text{ V}, I_{OL} = 8\text{ mA}$			0.3	
		$V_{CC} = 3\text{ V}, I_{OL} = 16\text{ mA}$			0.4	
		$V_{CC} = 3\text{ V}, I_{OL} = 24\text{ mA}$			0.55	
		$V_{CC} = 4.5\text{ V}, I_{OL} = 32\text{ mA}$			0.55	
Input leakage current	$I_L$	$V_I = 5.5\text{ V or GND}, V_{CC} = 0\text{ V to } 5.5\text{ V}$			$\pm 5$	$\mu\text{A}$
Power off leakage current	$I_{OFF}$	$V_I \text{ or } V_O = 5.5\text{ V}, V_{CC} = 0\text{ V}$			$\pm 10$	$\mu\text{A}$
Supply current	$I_{CC}$	$V_I = 5.5\text{ V or GND}, I_O = 0, V_{CC} = 2\text{ V to } 5.5\text{ V}$			10	$\mu\text{A}$
Additional supply current per input pin	$\Delta I_{CC}$	$V_{CC} = 3\text{ V to } 5.5\text{ V},$ one input at $V_{CC} - 0.6\text{ V},$ other input at $V_{CC}$ or GND			500	$\mu\text{A}$

### Switching Characteristics

Parameter	From (Input)	To (Output)	$V_{CC} = 2\text{ V} \pm 0.15\text{ V}$		$V_{CC} = 2.5\text{ V} \pm 0.2\text{ V}$		$V_{CC} = 3.3\text{ V} \pm 0.3\text{ V}$		$V_{CC} = 5\text{ V} \pm 0.5\text{ V}$		Units
			MIN	MAX	MIN	MAX	MIN	MAX	MIN	MAX	
$t_{PD}$	A	Y	2.8	9	1.2	5.5	1	4.5	1	4	nS
$t_{en}$	$\overline{OE}$	Y	3.3	10.1	1.5	6.6	1	5.3	1	5	nS
$t_{dis}$	$\overline{OE}$	Y	1.3	9.2	1	5	1	5	1	4.2	nS

### Typical Performance Characteristics

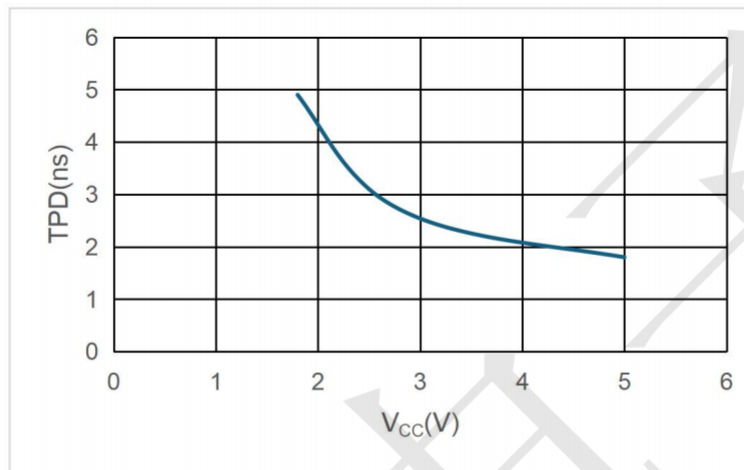

Figure 1. T<sub>PD</sub> across V<sub>CC</sub> at 25°C

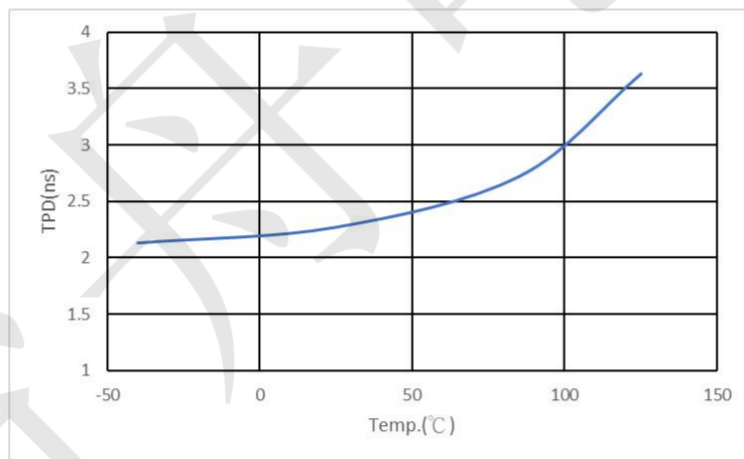
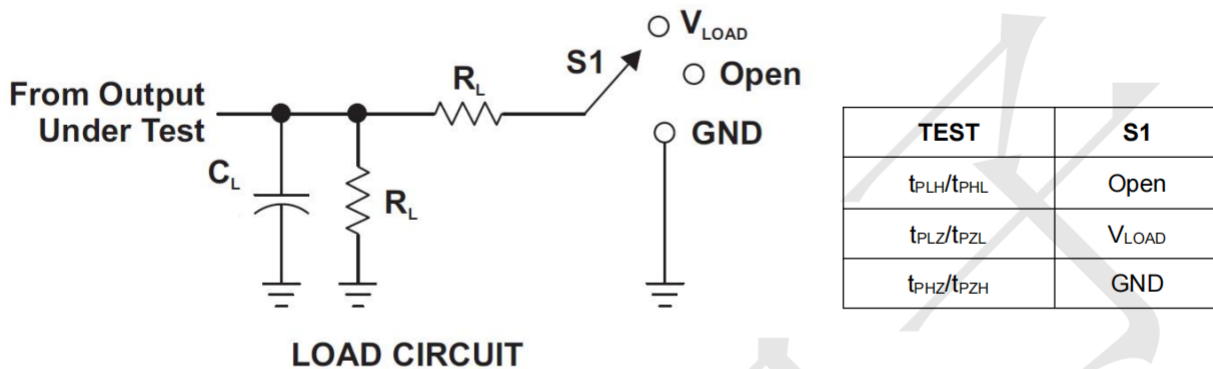
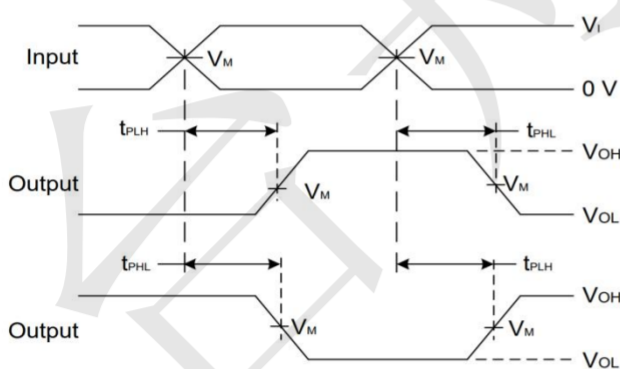

Figure 2. T<sub>PD</sub> across Temperature at 3.3 V V<sub>CC</sub>

### Parameter Measurement Information



$V_{CC}$	INPUTS		$V_M$	$V_{LOAD}$	$C_L$	$R_L$	$V_{\Delta}$
	$V_I$	$t_r/t_f$					
$2\text{ V} \pm 0.15\text{ V}$	$V_{CC}$	$\cong 2\text{ ns}$	$V_{CC}/2$	$2 \times V_{CC}$	30 pF	1 k $\Omega$	0.15 V
$2.5\text{ V} \pm 0.2\text{ V}$	$V_{CC}$	$\cong 2\text{ ns}$	$V_{CC}/2$	$2 \times V_{CC}$	30 pF	500 $\Omega$	0.15 V
$3.3\text{ V} \pm 0.3\text{ V}$	3 V	$\cong 2.5\text{ ns}$	1.5 V	6 V	50 pF	500 $\Omega$	0.3 V
$5\text{ V} \pm 0.5\text{ V}$	$V_{CC}$	$\cong 2.5\text{ ns}$	$V_{CC}/2$	$2 \times V_{CC}$	50 pF	500 $\Omega$	0.3 V



**Figure 3. Voltage Waveform Propagation Delay Times Inverting and Non Inverting Outputs**

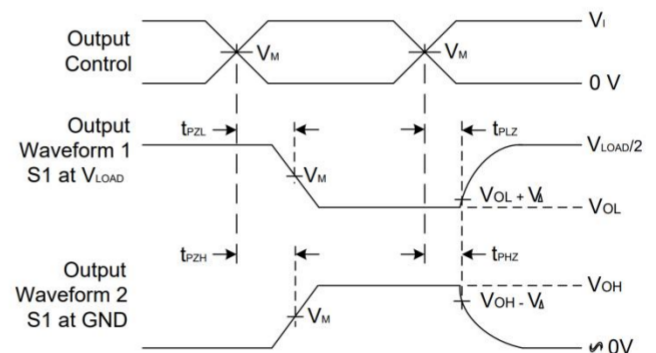

**Figure 4. Voltage Waveform Enable and Disable Times Low- and High-Level Enabling**

Notes:

- (1)  $C_L$  includes probe and jig capacitance.
- (2) All pulses and supplied at pulse repetition rate  $\leq 10\text{ MHz}$ .
- (3) The Inputs are measured separately one transition per measurement.
- (4)  $t_{PLZ}$  and  $t_{PHZ}$  are the same as  $t_{dis}$ .
- (5)  $t_{PZL}$  and  $t_{PZH}$  are the same as  $t_{en}$ .
- (6)  $t_{PLH}$  and  $t_{PHL}$  are the same as  $t_{PD}$ .

### Package Outline Dimension Unit (mm)

#### SOT23-5

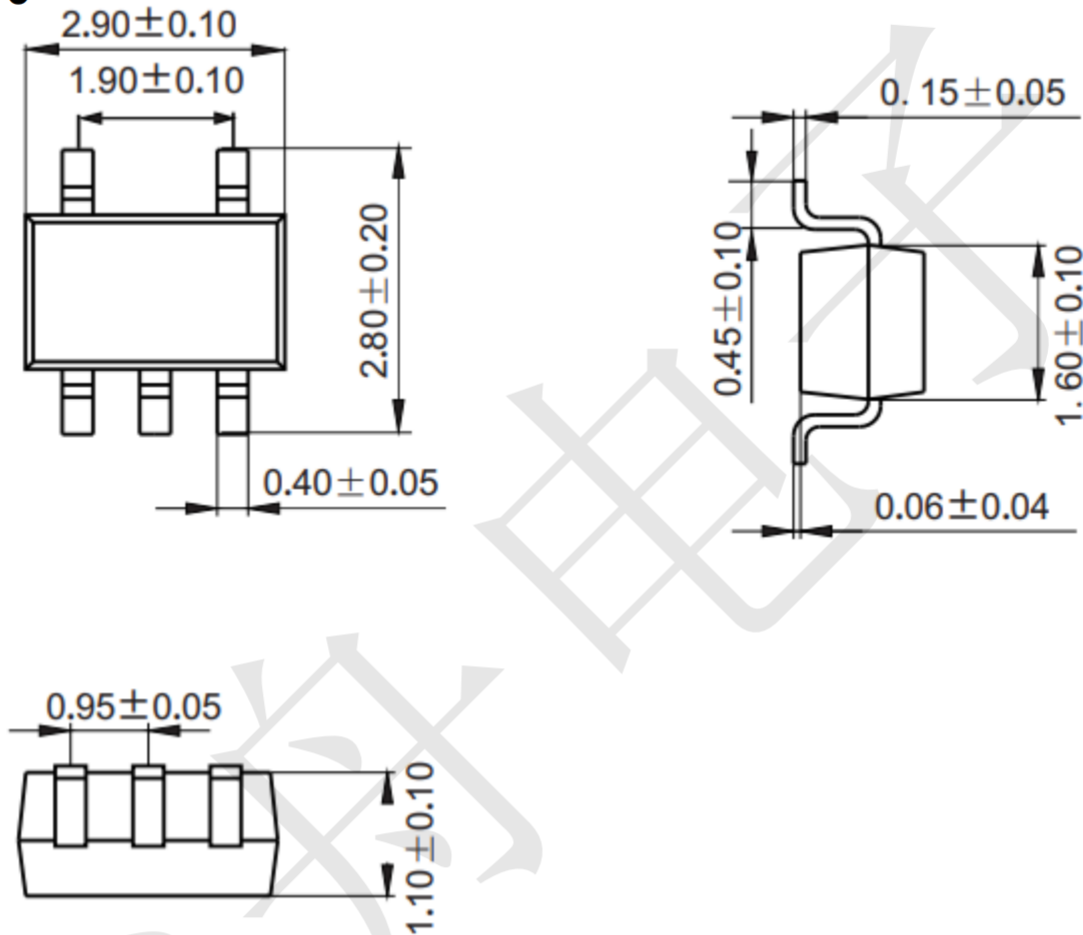

### Mounting Pad Layout (unit: mm)

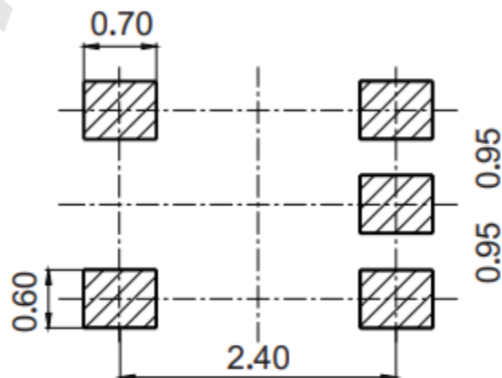

### Package Outline Dimension Unit (mm)

#### SOT353

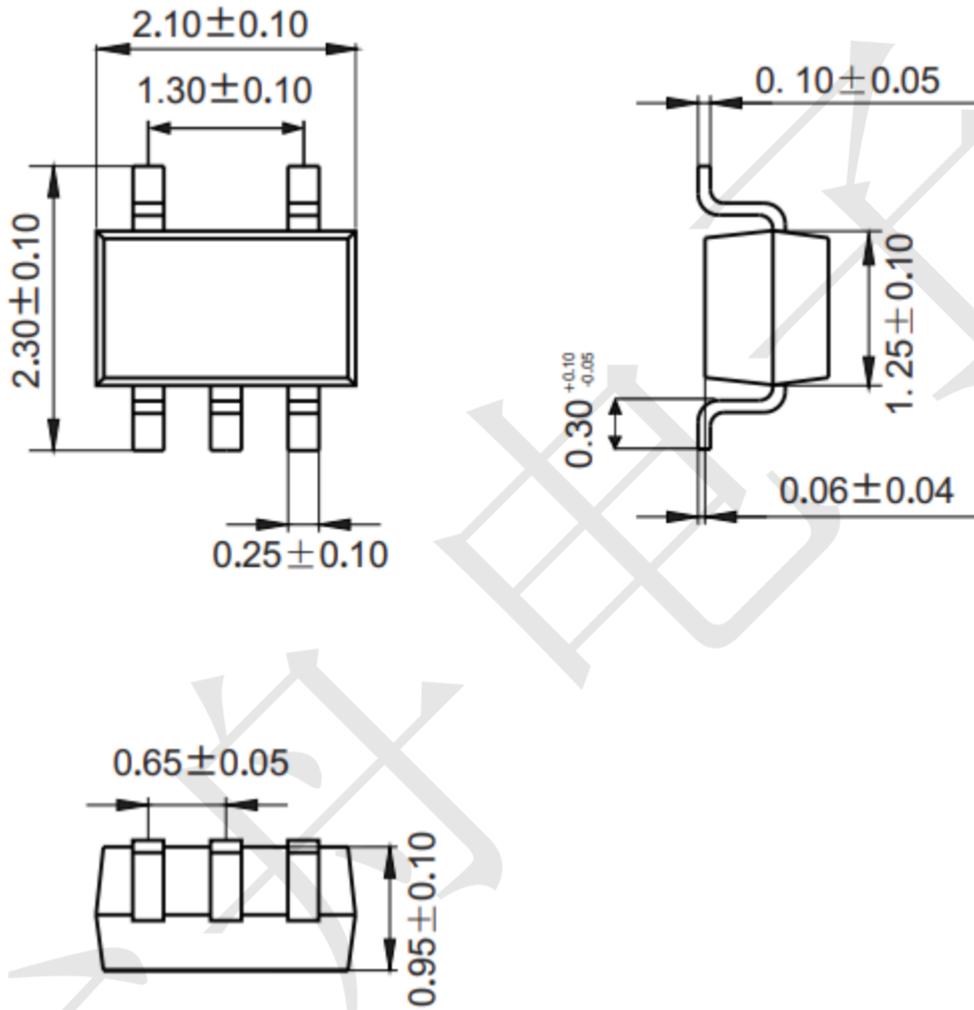

### Mounting Pad Layout (unit: mm)

