

General Description

The TC7SH17 is a single Schmitt-trigger buffer. The device is designed for 2 V to 5.5 V for V_{CC} operation, it can be driven from either 3.3V or 5V devices. This feature allows the use of these devices as translators in mixed 3.3V and 5V environments.

The TC7SH17 device contains one buffer and performs the Boolean function $Y = A$.

The CMOS device has high output drive while maintaining low static power dissipation over a broad V_{CC} operating range.

The TC7SH17 is available in SOT23-5 and SOT353 packages.

Features

- ◆ Wide Supply Voltage Range : 2 V to 5.5 V
- ◆ Max. T_{PD} of 6.5 ns at $V_{CC} = 3.3 V$
- ◆ Low Power Consumption, 10 μA (I_{CC} Max.)
- ◆ ± 24 mA Output Drive at $V_{CC} = 3.3 V$
- ◆ Latch-Up Performance Exceeds 100 mA Per JESD 78, Class II
- ◆ ESD Protection Exceeds JESD 22
 - 2000 V Human-Body Model (A114-A)
 - 1000 V Charged-Device Model (C101)
- ◆ Operating temperature Range : -40°C to 125°C
- ◆ Available Package : SOT23-5 and SOT353

Applications

- ◆ Active Noise Cancellation (ANC)
- ◆ Blood Pressure Monitor
- ◆ Embedded PC
- ◆ Solid State Drive (SSD) : Client and Enterprise
- ◆ TV : LCD/Digital and High-Definition (HDTV)
- ◆ Tablet : Enterprise
- ◆ Video Analytics : Server
- ◆ Wireless Headset, Keyboard, and Mouse
- ◆ Power Supply : Telecom/Server AC/DC Controller

Logic Diagram

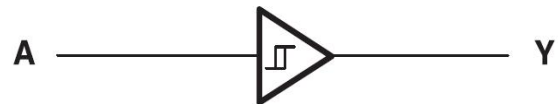

Ordering Information

ORDER NUMBER	PACKAGE DESCRIPTION	PACKAGE OPTION
TC7SH17F-TP	SOT23-5	Tape and Reel,3000
TC7SH17FU-TP	SOT353	Tape and Reel,3000

Pin Configuratio

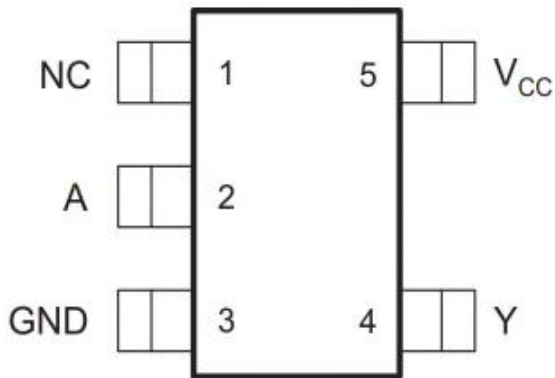

SOT23-5 and SOT353 (Top View)

Function Table(each gate)

H = HIGH voltage level; L = LOW voltage level

INPUTs	OUTPUT
A	Y
L	L
H	H

Pin Description

Pin		Description
Name	Num	
NC	1	No Connect
A	2	Data Input
GND	3	Ground
Y	4	Data Output
V _{cc}	5	Supply Power Input

Absolute Maximum Ratings

Over operating free-air temperature range (unless otherwise noted)⁽¹⁾

Parameter	Symbol	Value	Unit
Supply Voltage	V _{CC}	-0.5 to 6.5	V
Input Voltage	V _I	-0.5 to 6.5	V
Voltage range applied to any output in the high-impedance or power-off state ⁽²⁾	V _O	-0.5 to 6.5	V
Voltage range applied to any output in the high or low state ⁽²⁾⁽³⁾	V _O	-0.5 to V _{CC} +0.5	V
Input clamp current, V _I < 0	I _{IK}	-50	mA
Output clamp current, V _O < 0	I _{OK}	-50	mA
Continuous output current	I _O	±50	mA
Storage temperature range	T _{STG}	-65 to 150	°C
ESD HBM, ANSI/ESDA/JEDEC JS-001 ⁽⁴⁾	ESD _{HBM}	±2000	V
ESD CDM, JESD22-C101 ⁽⁵⁾	ESD _{CDM}	±1000	V

- (1) Stresses beyond those listed under absolute maximum ratings may cause permanent damage to the device. These are stress ratings only, and functional operation of the device at these or any other conditions beyond those indicated under recommended operating conditions is not implied. Exposure to absolute-maximum-rated conditions for extended periods may affect device reliability.
- (2) The input and output negative-voltage ratings may be exceeded if the input and output current ratings are observed.
- (3) The value of V_{CC} is provided in the Recommended Operating Conditions table.
- (4) JEDEC document JEP155 states that 500-V HBM allows safe manufacturing with a standard ESD control process.
- (5) JEDEC document JEP157 states that 250-V CDM allows safe manufacturing with a standard ESD control process.

Recommended Operating Conditions

Parameter	Symbol	Test Conditions	Min	Typ	Max	Unit
Supply voltage	V_{CC}	Operating	2		5.5	V
		Data retention only	2			
Input voltage	V_I		0		5.5	V
Output voltage	V_O				V_{CC}	V
High-level output current	I_{OH}	$V_{CC} = 2\text{ V}$			-4	mA
		$V_{CC} = 2.3\text{ V}$			-8	
		$V_{CC} = 3\text{ V}$			-16	
		$V_{CC} = 3\text{ V}$			-24	
		$V_{CC} = 4.5\text{ V}$			-32	
Low-level output current	I_{OL}	$V_{CC} = 2\text{ V}$			4	mA
		$V_{CC} = 2.3\text{ V}$			8	
		$V_{CC} = 3\text{ V}$			16	
		$V_{CC} = 3\text{ V}$			24	
		$V_{CC} = 4.5\text{ V}$			32	
Operating temperature	T_A		-40		125	°C

Electrical Characteristics

Parameter	Symbol	Test Conditions	Min	Typ	Max	Units
Positive-going input threshold voltage	V_{T+}	$V_{CC} = 2\text{ V}$	0.76		1.13	V
		$V_{CC} = 2.3\text{ V}$	1.08		1.56	
		$V_{CC} = 3\text{ V}$	1.48		1.92	
		$V_{CC} = 4.5\text{ V}$	2.19		2.74	
		$V_{CC} = 5.5\text{ V}$	2.65		3.33	
Negative-going input threshold voltage	V_{T-}	$V_{CC} = 2\text{ V}$	0.35		0.59	V
		$V_{CC} = 2.3\text{ V}$	0.56		0.88	
		$V_{CC} = 3\text{ V}$	0.89		1.2	
		$V_{CC} = 4.5\text{ V}$	1.51		1.97	
		$V_{CC} = 5.5\text{ V}$	1.88		2.4	
Hysteresis Voltage	ΔV_T	$V_{CC} = 2\text{ V}$	0.36		0.64	V
		$V_{CC} = 2.3\text{ V}$	0.45		0.78	
		$V_{CC} = 3\text{ V}$	0.51		0.83	
		$V_{CC} = 4.5\text{ V}$	0.58		0.93	
		$V_{CC} = 5.5\text{ V}$	0.69		1.04	
High-level output voltage	V_{OH}	$V_{CC} = 2\sim 5.5\text{ V}, I_{OH} = 100\ \mu\text{A}$	$V_{CC}-0.1$			V
		$V_{CC} = 2\text{ V}, I_{OH} = 4\text{ mA}$	1.2			
		$V_{CC} = 2.3\text{ V}, I_{OH} = 8\text{ mA}$	1.9			
		$V_{CC} = 3\text{ V}, I_{OH} = 16\text{ mA}$	2.4			
		$V_{CC} = 3\text{ V}, I_{OH} = 24\text{ mA}$	2.3			
		$V_{CC} = 4.5\text{ V}, I_{OH} = 32\text{ mA}$	3.8			
Low-level output voltage	V_{OL}	$V_{CC} = 2\sim 5.5\text{ V}, I_{OL} = 100\ \mu\text{A}$			0.1	V
		$V_{CC} = 2\text{ V}, I_{OL} = 4\text{ mA}$			0.45	
		$V_{CC} = 2.3\text{ V}, I_{OL} = 8\text{ mA}$			0.3	
		$V_{CC} = 3\text{ V}, I_{OL} = 16\text{ mA}$			0.4	
		$V_{CC} = 3\text{ V}, I_{OL} = 24\text{ mA}$			0.55	
		$V_{CC} = 4.5\text{ V}, I_{OL} = 32\text{ mA}$			0.55	
Input leakage current	I_L	$V_{IN} = 5.5\text{ V or GND}, V_{CC} = 0\sim 5.5\text{ V}$			± 5	μA
Power off leakage current	I_{OFF}	$V_{IN} \text{ or GND}, V_{CC} = 0\sim 5.5\text{ V}$			± 10	μA
Quiescent supply current	I_Q	$V_{IN} = V_{CC} \text{ or GND}, I_{OUT} = 0, V_{CC} = 2\sim 5.5\text{ V}$			10	μA
Additional quiescent supply current per input pin	ΔI_Q	$V_{CC} = 3\sim 5.5\text{ V}, \text{one input at } V_{CC}-0.6\text{ V}, \text{other input at } V_{CC} \text{ or GND}$			500	μA

Switching Characteristics

Parameter	Symbol	Test Conditions	Min	Typ	Max	Unit
Propagation delay from input (A) to output (Y)	T _{PD}	V _{CC} = 2 V ± 0.15 V, R _L = 1 kΩ	3.8	13	nS	
		V _{CC} = 2.5 V ± 0.2 V R _L = 500 Ω				
		V _{CC} = 3.3 V ± 0.3 V R _L = 500 Ω	1.8	6.5	nS	
		V _{CC} = 5 V ± 0.5 V R _L = 500 Ω				

Typical Performance Characteristics

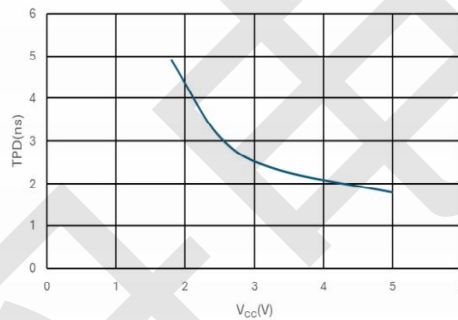
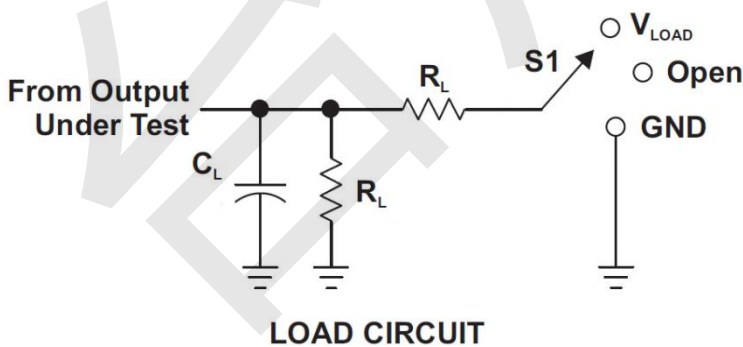

Figure 1. T_{PD} across V_{CC} at 25°C

Parameter Measurement Information



Test	S1
t _{PLH} /t _{PHL}	Open
t _{PLZ} /t _{PZL}	V _{LOAD}
t _{PHZ} /t _{PZH}	GND

V _{CC}	INPUTS		V _M	V _{LOAD}	C _L	R _L	V _Δ
	V _I	t _r /t _f					
2 V ± 0.15 V	V _{CC}	≤ 2 ns	V _{CC} /2	2 x V _{CC}	30 pF	1 kΩ	0.15 V
2.5 V ± 0.2 V	V _{CC}	≤ 2 ns	V _{CC} /2	2 x V _{CC}	30 pF	500 Ω	0.15 V
3.3 V ± 0.3 V	3 V	≤ 2.5 ns	1.5 V	6 V	50 pF	500 Ω	0.3 V
5 V ± 0.5 V	V _{CC}	≤ 2.5 ns	V _{CC} /2	2 x V _{CC}	50 pF	500 Ω	0.3 V

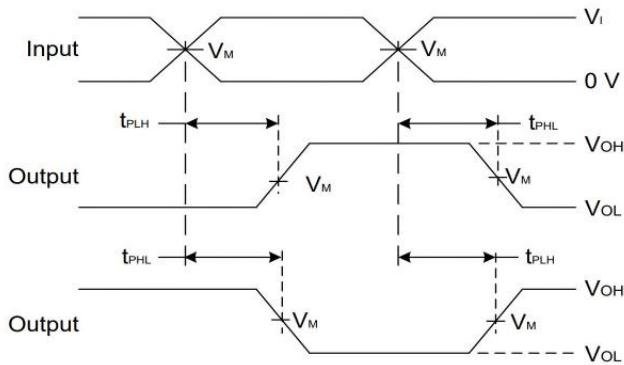

Figure 2. Voltage Waveform Propagation Delay Times Inverting and Non Inverting Outputs

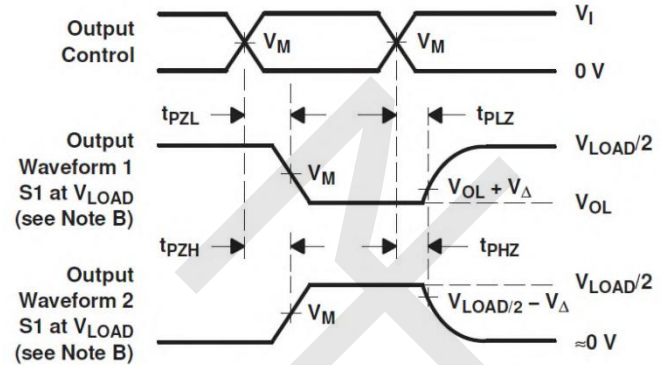

Figure 3. Voltage Waveform Enable and Disable Times Low- and High-Level Enabling

Notes:

- (1) C_L includes probe and jig capacitance.
- (2) Waveform 1 is for an output with internal conditions such that the output is low, except when disabled by the output control.
Waveform 2 is for an output with internal conditions such that the output is high, except when disabled by the output control.
- (3) All pulses and supplied at pulse repetition rate ≤ 10 MHz.
- (4) The Inputs are measured separately one transition per measurement.

Package Outline Dimension Unit (mm)

SOT23-5

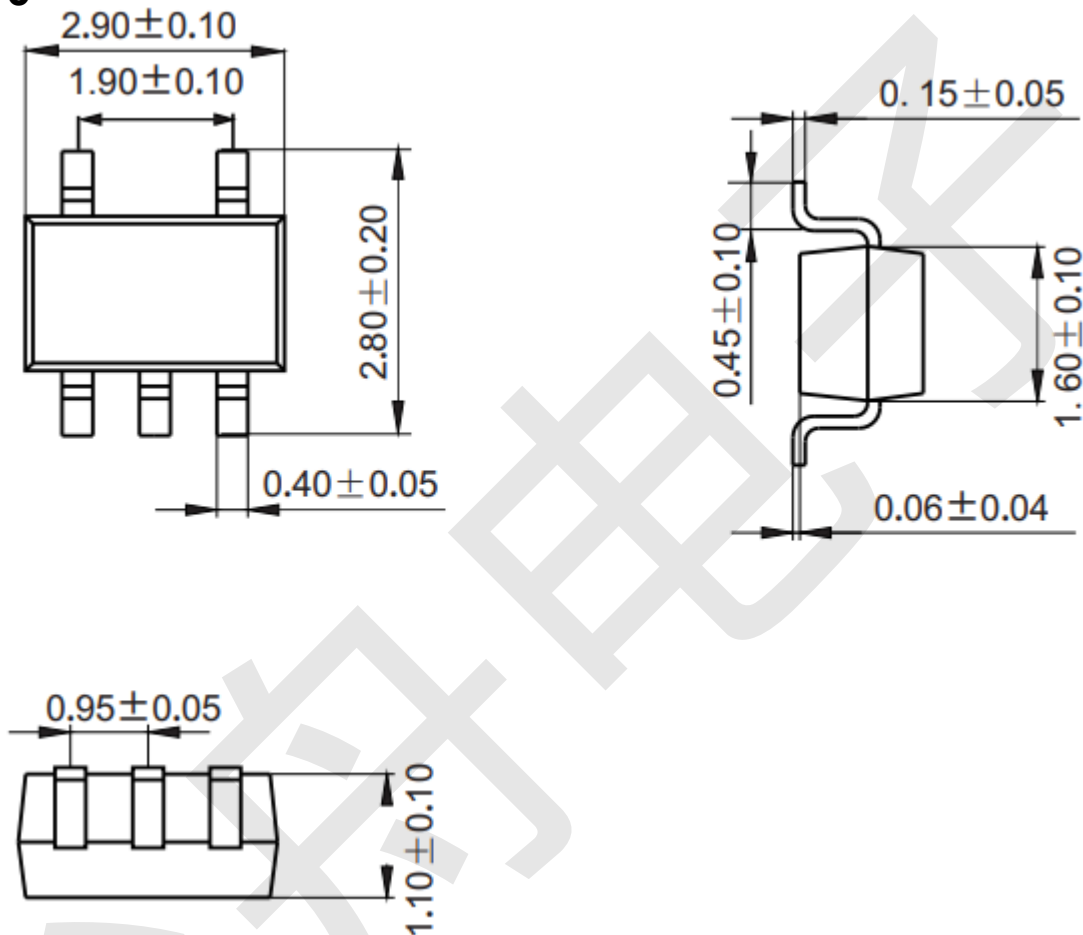

Mounting Pad Layout (unit: mm)

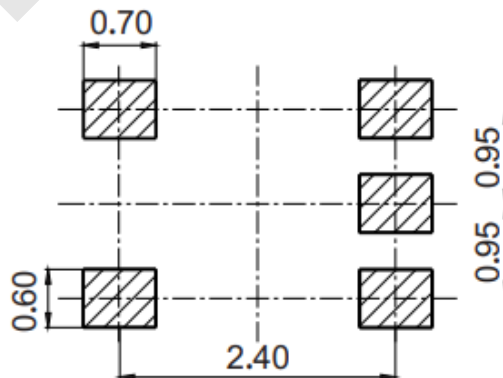

Package Outline Dimension Unit (mm)

SOT353

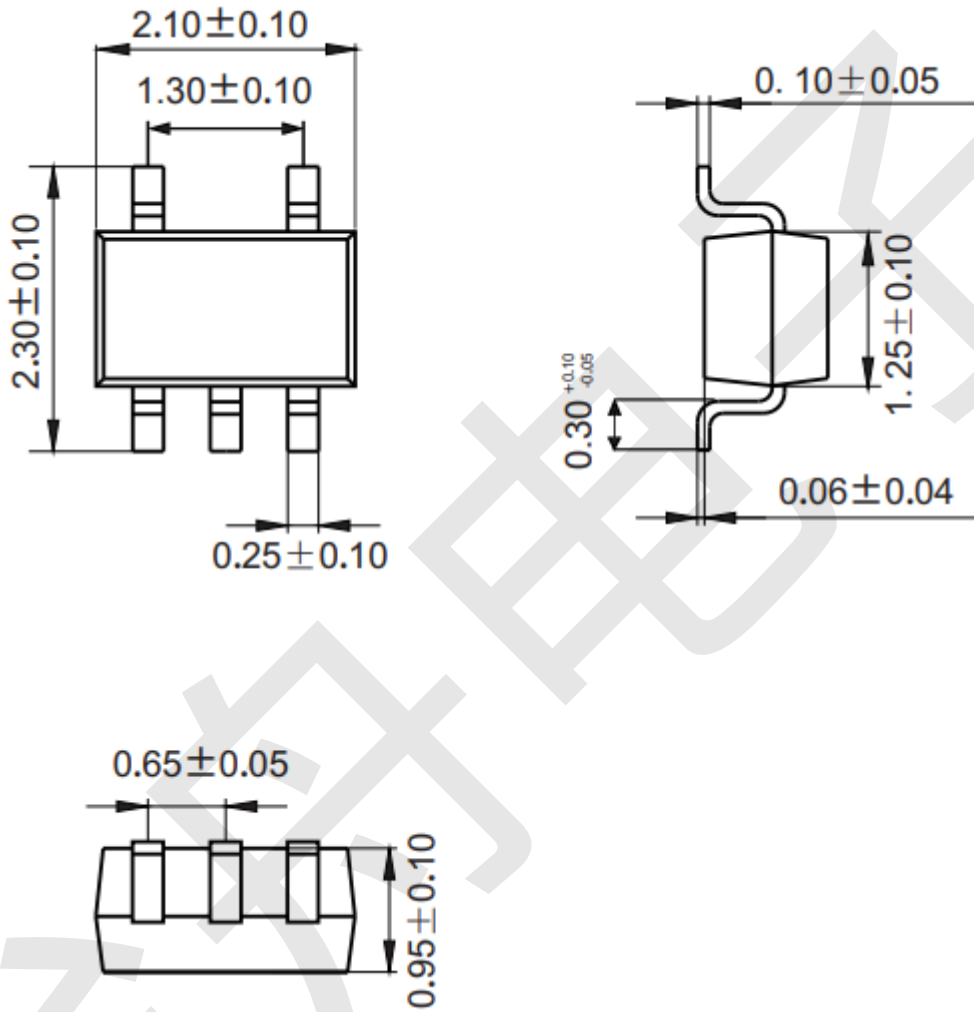

Mounting Pad Layout (unit: mm)

