

### Features

- Wide supply voltage range from 0.9V to 2.7V
- $\pm 8\text{mA}$  Output Driver :  $V_{CC}=1.8\text{V}$
- $I_{OFF}$  Supports partial-Power-Down Mode  
Operation and back drive protection
- Low static power consumption;  $I_{CC}=10\mu\text{A}$  (Max.)
- ESD Protection Exceeds JESD 22
  - 2000-V Human-Body Model (A114-A)
  - 200-V Machine Model (A115-A)
  - 1000-V Charged-Device Model (C101)

### General Description

The TP74AUC1G125 is a single line driver with a 3-state output. When  $\overline{OE}$  is high, the Y output are in a high-impedance state. When  $\overline{OE}$  is low, the device passes noninverted data from the A input to the Y output.

### Applications

- AV Receiver
- Audio Dock: Portable
- Blu-ray Player and Home Theater
- Embedded PC
- Personal Digital Assistant(PDA)
- Power: Telecom/Server AC/DC Supply: Single Controller: Analog and Digital
- Solid State Drive(SSD): Client and Enterprise
- Wireless Headset, Keyboard, and Mouse

### Logic Diagram

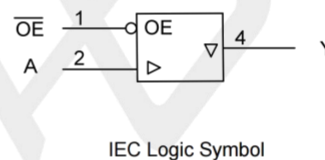
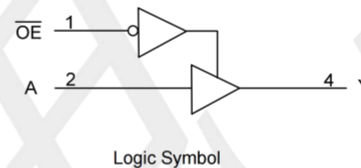

### Ordering Information

ORDER NUMBER	PACKAGE DESCRIPTION	PACKAGE OPTION
TP74AUC1G125S5	SOT23-5	Tape and Reel, 3000
TP74AUC1G125C5	SOT353	Tape and Reel, 3000

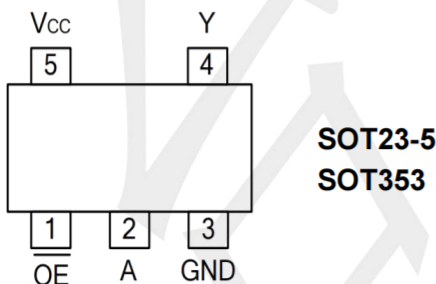

### Function Table (each gate)

INPUT( $\overline{OE}$ )	INPUT(A)	OUTPUT(Y)
L	L	L
L	H	H
H	X	Z

**H: HIGH voltage level; L: LOW voltage level;**  
**X=don't care; Z=high-impedance OFF-state.**

## Absolute Maximum Ratings

PARAMETER	SYMBOL	TEST CONDITIONS	RATINGS	UNIT
Supply Voltage	$V_{CC}$		-0.5 ~ +3.6	V
Input Voltage	$V_{IN}$		-0.5 ~ +3.6	V
Output Voltage	$V_{OUT}$	Enable mode	-0.5 ~ $V_{CC} + 0.5$	V
		Power-down mode	-0.5 ~ +3.6	V
$V_{CC}$ or GND Current	$I_{CC}$		±100	mA
Continuous Output Current	$I_{OUT}$	$V_{OUT}=0 \sim V_{CC}$	±20	mA
Input Clamp Current	$I_{IK}$	$V_{IN} < 0$	-50	mA
Output Clamp Current	$I_{OK}$	$V_{OUT} < 0$	-50	mA
Storage Temperature Range	$T_{STG}$		-65 ~ +150	°C

Note: Absolute maximum ratings are those values beyond which the device could be permanently damaged. Absolute maximum ratings are stress ratings only and functional device operation is not implied.

## Recommended Operating Conditions

PARAMETER	SYMBOL	TEST CONDITIONS	MIN	TYP	MAX	UNIT
Supply Voltage	$V_{CC}$	Operating	0.9	--	2.7	V
Input Voltage	$V_{IN}$		0	--	3.6	V
Output Voltage	$V_{OUT}$	High or low state	0	--	$V_{CC}$	V
Operating Temperature	$T_A$		-40	--	+125	°C
Input Transition Rise or Fall Rate	$\Delta t/\Delta v$	$V_{CC}=0.9V \sim 1.6V$	--	--	20	ns/V
		$V_{CC}=1.65V \sim 1.95V$	--	--	10	ns/V
		$V_{CC}=2.3V \sim 2.7V$	--	--	3	ns/V

## Electrical Characteristics (T<sub>A</sub>=25°C, unless otherwise specified)

PARAMETER	SYMBOL	TEST CONDITIONS	T <sub>A</sub> =25°C			T <sub>A</sub> =-40~+125°C			UNIT
			MIN	TYP	MAX	MIN	TYP	MAX	
High-level Input Voltage	V <sub>IH</sub>	V <sub>CC</sub> =0.9V	V <sub>CC</sub>	--	--	V <sub>CC</sub>	--	--	V
		V <sub>CC</sub> =1.1V ~ 1.95V	0.65× V <sub>CC</sub>	--	--	0.65× V <sub>CC</sub>	--	--	V
		V <sub>CC</sub> =2.3V ~ 2.7V	1.7	--	--	1.7	--	--	V
Low-level Input Voltage	V <sub>IL</sub>	V <sub>CC</sub> =0.9V	--	--	0	--	--	0	V
		V <sub>CC</sub> =1.1V ~ 1.95V	--	--	0.35× V <sub>CC</sub>	--	--	0.35× V <sub>CC</sub>	V
		V <sub>CC</sub> =2.3V ~ 2.7V	--	--	0.7	--	--	0.7	V
High-Level Output Voltage	V <sub>O<sub>H</sub></sub>	V <sub>CC</sub> =0.9V ~ 2.7V, I <sub>OH</sub> =-100μA	V <sub>CC</sub> -0.1	--	--	V <sub>CC</sub> -0.1	--	--	V
		V <sub>CC</sub> =0.9V, I <sub>OH</sub> =-0.7mA	--	0.45	--	--	0.45	--	V
		V <sub>CC</sub> =1.1V, I <sub>OH</sub> =-3mA	0.8	--	--	0.6	--	--	V
		V <sub>CC</sub> =1.4V, I <sub>OH</sub> =-5mA	1	--	--	0.8	--	--	V
		V <sub>CC</sub> =1.65V, I <sub>OH</sub> =-8mA	1.2	--	--	1	--	--	V
		V <sub>CC</sub> =2.3V, I <sub>OH</sub> =-9mA	1.8	--	--	1.6	--	--	V
Low-Level Output Voltage	V <sub>O<sub>L</sub></sub>	V <sub>CC</sub> =0.9V ~ 2.7V, I <sub>OL</sub> =100μA	--	--	0.2	--	--	0.2	V
		V <sub>CC</sub> =0.9V, I <sub>OL</sub> =0.7mA	--	0.25	--	--	0.35	--	V
		V <sub>CC</sub> =1.1V, I <sub>OL</sub> =3mA	--	--	0.3	--	--	0.4	V
		V <sub>CC</sub> =1.4V, I <sub>OL</sub> =5mA	--	--	0.4	--	--	0.5	V
		V <sub>CC</sub> =1.65V, I <sub>OL</sub> =8mA	--	--	0.45	--	--	0.6	V
		V <sub>CC</sub> =2.3V, I <sub>OL</sub> =9mA	--	--	0.6	--	--	0.8	V
Input Leakage Current	I <sub>I(LEAK)</sub>	V <sub>CC</sub> =2.7V, V <sub>IN</sub> =V <sub>CC</sub> or GND	--	--	±5	--	--	±5	μA
Power Leakage Current	I <sub>OFF</sub>	V <sub>CC</sub> =0V, V <sub>IN</sub> or V <sub>OUT</sub> =2.7V	--	--	±10	--	--	±10	μA
3-state OFF-state Current	I <sub>OZ</sub>	V <sub>CC</sub> =2.7V, V <sub>OUT</sub> =V <sub>CC</sub> or GND	--	--	±10	--	--	±10	μA
Quiescent Current	I <sub>CC</sub>	V <sub>CC</sub> =0.9V to 2.7V, V <sub>IN</sub> =V <sub>CC</sub> or GND, I <sub>OUT</sub> =0	--	--	10	--	--	10	μA

## SWITCHING CHARACTERISTICS (TA = 25°C, unless otherwise specified)

PARAMETER	SYMBOL	TEST CONDITIONS	TA=25°C			TA=-40~+125°C			UNIT	
			MIN	TYP	MAX	MIN	TYP	MAX		
Propagation Delay from Input (A) to Output (Y)	tPLH / tPHL	CL=15pF, RL=2kΩ	VCC=0.9V	--	25	--	--	25	--	ns
			VCC=1.2±0.1V	6.1	--	10.5	5.5	--	12.5	ns
			VCC=1.5±0.1V	4.5	--	8.5	3.5	--	10.5	ns
			VCC=1.8±0.15V	2.5	--	5.5	1.5	--	7.5	ns
			VCC=2.5±0.2V	1	--	3.1	0.5	--	5	ns
		CL=30pF, RL=1kΩ	VCC=1.8±0.15V	2.5	--	5.5	1.8	--	7.5	ns
		CL=30pF, RL=500Ω	VCC=2.5±0.2V	1.5	--	3.5	0.8	--	5.5	ns
3-State Output Enable time from Input (OE) to Output (Y)	tPZH / tPZL	CL=15pF, RL=2kΩ	VCC=0.9V	--	25	--	--	25	--	ns
			VCC=1.2±0.1V	8.5	--	13	7.5	--	14.5	ns
			VCC=1.5±0.1V	6	--	10	5.5	--	11.5	ns
			VCC=1.8±0.15V	4	--	7	3.5	--	8.5	ns
			VCC=2.5±0.2V	0.5	--	3.3	0.2	--	4.5	ns
		CL=30pF, RL=1kΩ	VCC=1.8±0.15V	4.5	--	7.5	3.5	--	8.5	ns
		CL=30pF, RL=500Ω	VCC=2.5±0.2V	0.8	--	4	0.4	--	5.5	ns
3-State Output Disable time from Input (OE) to Output (Y)	tPLZ / tPHZ	CL=15pF, RL=2kΩ	VCC=0.9V	--	25	--	--	25	--	ns
			VCC=1.2±0.1V	3.8	--	9.5	2.5	--	12.5	ns
			VCC=1.5±0.1V	2.3	--	8.6	1.8	--	10.5	ns
			VCC=1.8±0.15V	1.5	--	7.2	1	--	9.2	ns
			VCC=2.5±0.2V	0.9	--	5	0.5	--	6.5	ns
		CL=30pF, RL=1kΩ	VCC=1.8±0.15V	1.8	--	7.2	1.1	--	8.5	ns
		CL=30pF, RL=500Ω	VCC=2.5±0.2V	0.8	--	4	0.4	--	5.5	ns

## OPERATING CHARACTERISTICS (f=10MHz, TA =25°C , unless otherwise specified)

PARAMETER	SYMBOL	TEST CONDITIONS	MIN	TYP	MAX	UNIT
Input Capacitance	C <sub>i</sub>	V <sub>CC</sub> =2.5V, V <sub>IN</sub> =V <sub>CC</sub> or GND	--	5	--	pF
Output Capacitance	C <sub>o</sub>	V <sub>CC</sub> =2.5V, V <sub>IN</sub> =V <sub>CC</sub> or GND	--	7.6	--	pF
Power Dissipation Capacitance (Outputs enabled)	C <sub>PD</sub>	V <sub>CC</sub> =0.9V	--	14	--	pF
		V <sub>CC</sub> =1.2V	--	14	--	pF
		V <sub>CC</sub> =1.5V	--	14	--	pF
		V <sub>CC</sub> =1.8V	--	15	--	pF
		V <sub>CC</sub> =2.5V	--	16	--	pF
Power Dissipation Capacitance (Outputs Disabled)	C <sub>PD</sub>	V <sub>CC</sub> =0.9V	--	1.5	--	pF
		V <sub>CC</sub> =1.2V	--	1.5	--	pF
		V <sub>CC</sub> =1.5V	--	1.5	--	pF
		V <sub>CC</sub> =1.8V	--	2	--	pF
		V <sub>CC</sub> =2.5V	--	2.5	--	pF

## TEST CIRCUIT AND WAVEFORMS

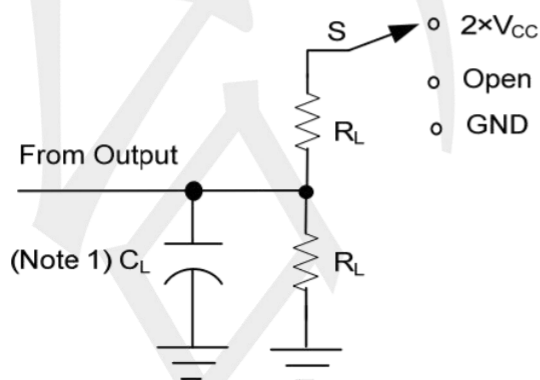

TEST CIRCUIT

TEST	S
t <sub>PLH</sub> /t <sub>PHL</sub>	Open
t <sub>PHZ</sub> /t <sub>PZH</sub>	GND
t <sub>PLZ</sub> /t <sub>PZL</sub>	2×V <sub>CC</sub>

## TEST CIRCUIT AND WAVEFORMS(Cont.)

$V_{CC}$	$C_L$	$R_L$	$V_{\Delta}$
0.9V	15pF	2k $\Omega$	0.1V
1.2V $\pm$ 0.1V	15pF	2k $\Omega$	0.1V
1.5V $\pm$ 0.1V	15pF	2k $\Omega$	0.1V
1.8V $\pm$ 0.15V	15pF	2k $\Omega$	0.15V
2.5V $\pm$ 0.2V	15pF	2k $\Omega$	0.15V
1.8V $\pm$ 0.15V	30pF	1k $\Omega$	0.15V
2.5V $\pm$ 0.2V	30pF	500 $\Omega$	0.15V

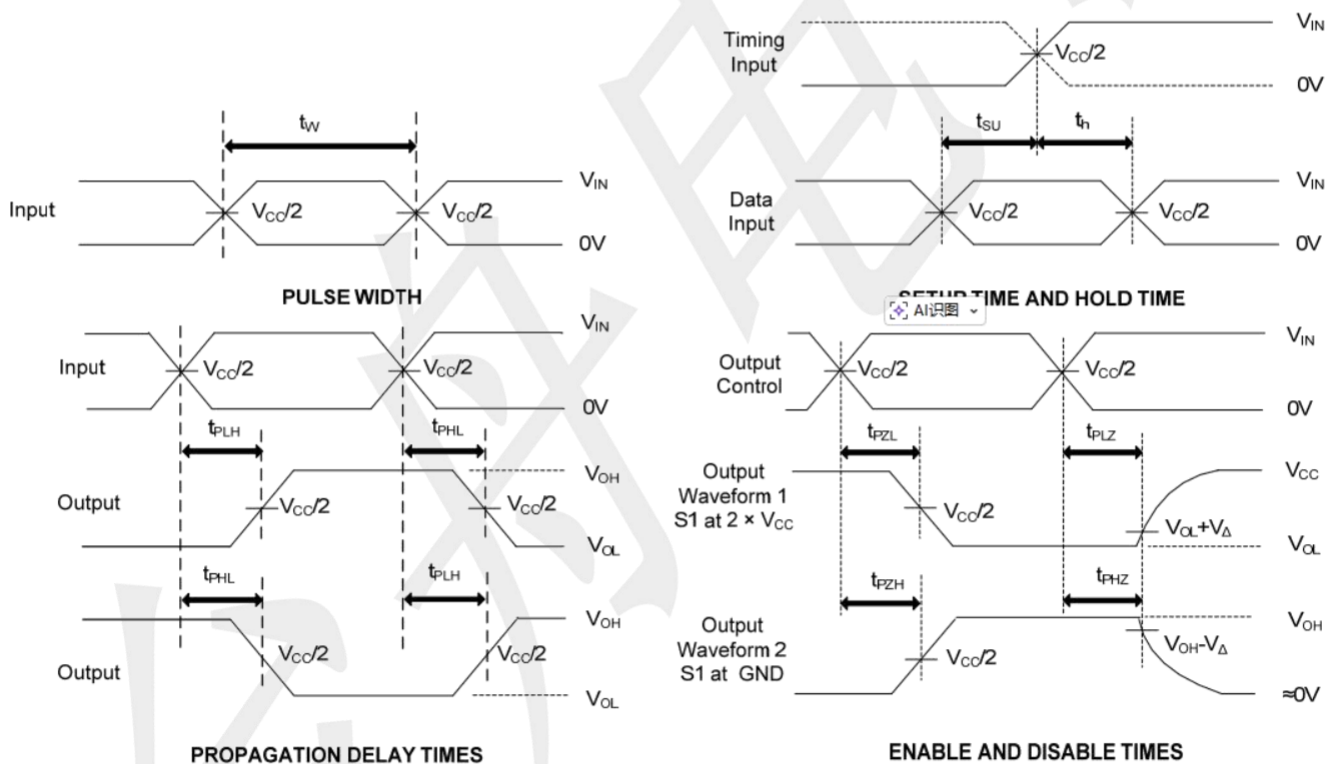

Notes: 1.  $C_L$  includes probe and jig capacitance.

2. Waveform 1 is for an output with internal conditions such that the output is low, except when disabled by the output control.

Waveform 2 is for an output with internal conditions such that the output is high, except when disabled by the output control

3. All input pulses are supplied by generators having the following characteristics: PRR 10 MHz,  $Z = 50 \Omega$ , slew rate 1 V/ns.

4. The outputs are measured one at a time, with one transition per measurement.

5.  $t_{PLZ}$  and  $t_{PHZ}$  are the same as  $t_{dis}$ .

6.  $t_{PZL}$  and  $t_{PZH}$  are the same as  $t_{en}$ .

7.  $t_{PLH}$  and  $t_{PHL}$  are the same as  $t_{PD}$

**Package information (Unit: mm)**

SOT23-5

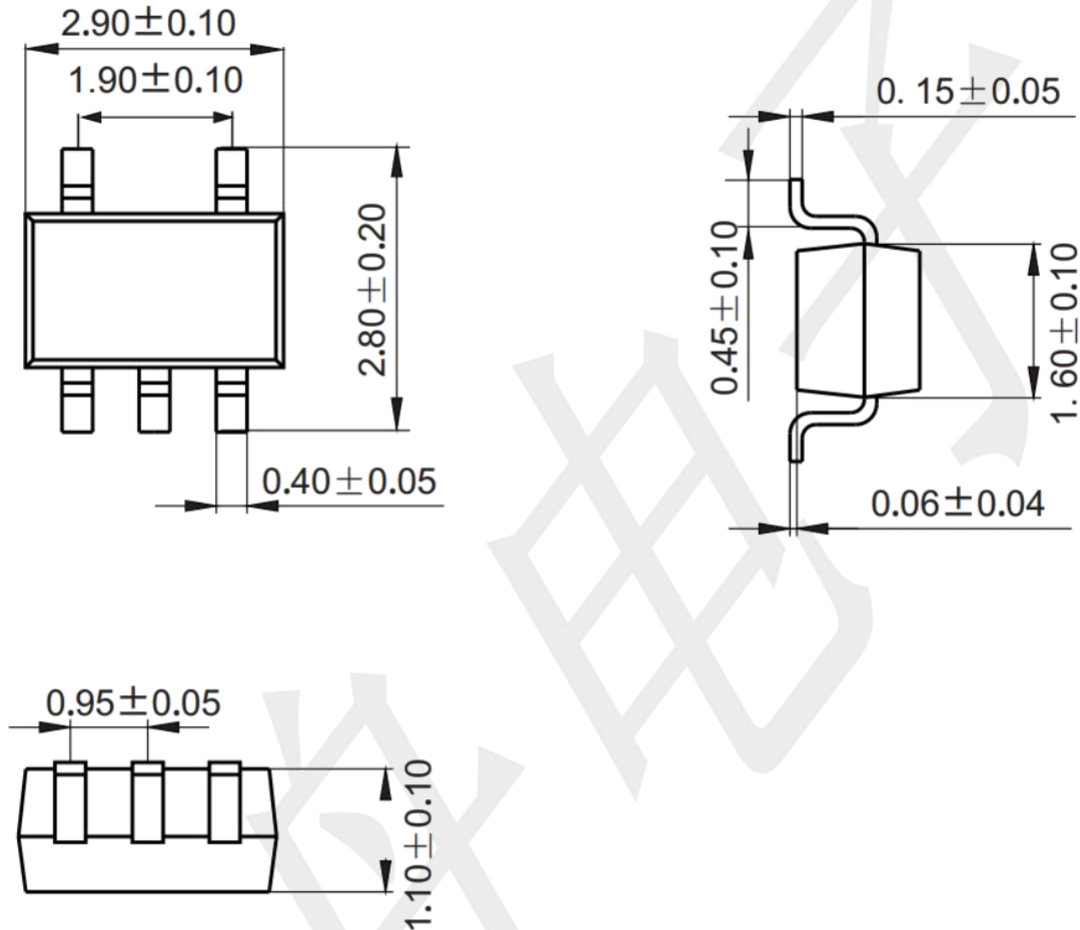

**Mounting Pad Layout (unit: mm)**

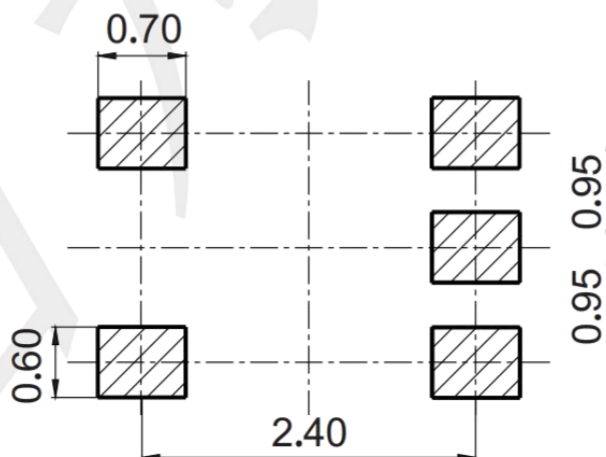

**Package information (Unit: mm)**

SOT353

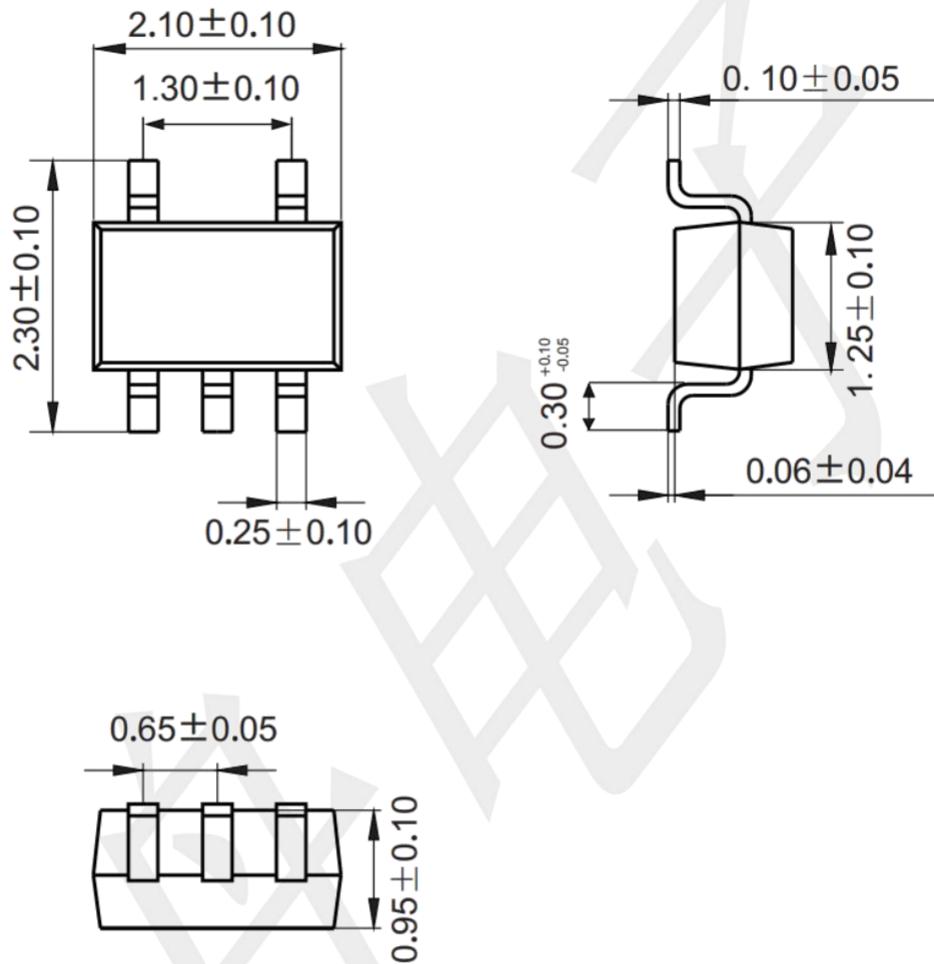

**Mounting Pad Layout (unit: mm)**

