



上海永铭电子股份有限公司

规格书

Specification For Approval

客户 Customer :
日期 Date:

品名 Item:	导电性高分子固体铝电解电容 Conductive Polymer Aluminum Solid Electrolytic Capacitors
型号 Series:	NPX
版本 Version :	00
物料号 Customer P/N :	

客户确认 Client Confirmed	
批准 Approved by	审核 Checked by

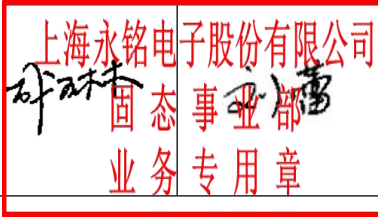
批准 Approved by		
批准 Approved by	审核 Checked by	拟制 Prepared by
孙涛	孙涛	

承认书请寄回一份

Please Return One Copy with Your Approval

上海永铭电子股份有限公司

Shanghai Yongming Electronic Co., Ltd.

客户 Customer

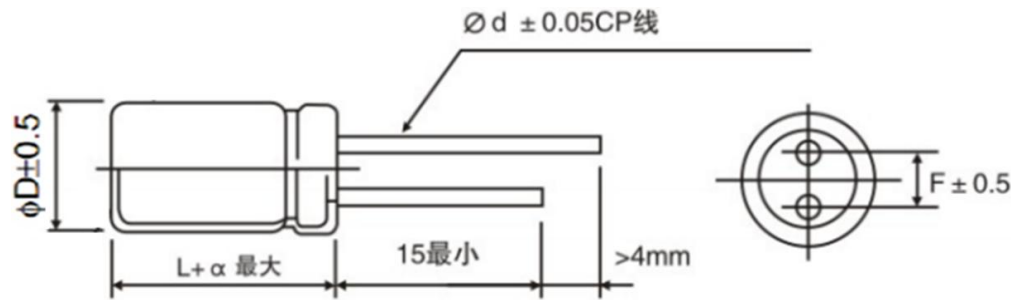

$\phi 5 \sim \phi 6.3$



$\phi 8 \sim \phi 10$

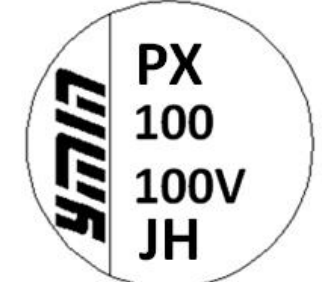

$\phi 12.5 \sim \phi 18$

D	5	5.5	6.3	8	10	12.5
d (± 0.05)	0.45/0.50	0.45/0.50	0.45/0.50	0.60	0.60	0.60
F (± 0.5)	2.0	2.5	2.5	3.5	5.0	5.0

TABLE-1

No	客户 物料编码 Customer Part No	永铭 物料编码 Ymin Part No	额定 电压 Rated Voltage (V.DC)	标称 容量 Cap (μ F)	浪涌电压 Surge Voltage (V.DC)	工作温度范围 Operating Temp.Range ($^{\circ}$ C)	容量范围 Capacitance Tolerance	损耗 Tan δ 20 \pm 2 $^{\circ}$ C 120Hz (% max)	等效串联电阻 ESR(Ω) 20 \pm 2 $^{\circ}$ C 100KHz (Ω max)	纹波电流 Ripple Current 105 $^{\circ}$ C 100KHz (mA)	漏电流 Leakage Current 20 \pm 2 $^{\circ}$ C U _R , 2mins (μ A max)	寿命 Load Life 105 $^{\circ}$ C (Hours)	尺寸 Dimensions(mm) (mm)		
													ϕ D	L	α
1		NPXD0901C561MJTM	16	560	18.4	-55~+105	$\pm 20\%$	8	0.012	4700	1792	2000	8	9	± 1.0
2															
3															
4															
5															
6															

1 概述 SCOPE

本承认书规定了导电性高分子固体铝电解电容的技术规范。

This Specification For Approval specifies the Conductive Polymer Aluminum Solid Electrolytic Capacitors .

2 参考标准 APPLICABLE SPECIFICATION

本承认书参考 JISC-5141 和 JISC-5102 制定。

This approval sheet consulted the institute of JISC-5141 and JISC-5102.

3 工作温度范围 OPERATING TEMPERATURE RANGE (-55~+105 °C)

工作温度范围:电容器在施加额定工作电压和额定纹波电流的条件下, 可以长期可靠工作的环境温度范围。

Operating temperature range is the range of ambient temperature at which the capacitors can be operated continuously at rated voltage.

4 测试环境 CHARACTERISTICS

如果没有其他规定, 标准的测试、检验环境条件如下所示:

环境温度: 20°C±2°C

相对湿度: 60±15%

大气压力: 86kpa~106kpa

Unless otherwise specified, the standard range of atmospheric conditions for making measurements and tests are as follows.

Ambient temperature : 20°C ± 2°C

Relative humidity : 60±15%

Air pressure : 86kpa to 106kpa

名称	Name	规格书			Specification
版本	Version	03	页数	Page	3
		标准指南	Standard Manual		

5 产品特性 PRODUCT CHARACTERISTICS

5.1 电气特性 ELECTRICAL CHARACTERISTICS

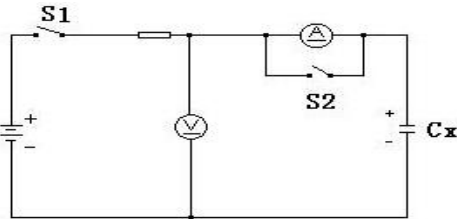
序号 NO	项目 Item	测试方法 Test method	性能 Performance
5.1.1	额定工作电压 Rated voltage		6.3~100 V.DC
5.1.2	电容量 Capacitance	测试频率: 120Hz±10% 测试电路: 串联等效电路 测试电压: 0.5Vrms Measuring frequency: 120Hz±10% Measuring circuit: Series equivalent circuit Measuring voltage: 0.5Vrms	见表 1 Refer to TABLE-1
5.1.3	损耗角正切值 Dissipation Factor	测试条件与 5.1.2 电容量测试相同 Testing condition are the same as 5.1.2 for capacitance	见表 1 Refer to TABLE-1
5.1.4	漏电流 Leakage current	<p>在电容器两端施加额定工作电压, 并串联 1000±100Ω电阻, 在施加电压 2 分钟后, 测量漏电流。 测试电路如下图:</p> <p>The rated voltage shall be applied across the capacitors and its protective resistor which shall be 1000±100Ω. The leakage current shall then be measured after an electrification period of 2 min.. Measurement circuit .</p>  <p>Rs: 保护电阻 (1000±100Ω) Rs: Protective resistor(1000±100Ω) V: 直流电压表 ; V: DC voltage meter A: 直流电流表; A: DC AM meter S₁: 开关 ; S₁:Switch S₂: 电流表保护开关 ; S₂:Protective switch for an ammeter 备注: 充电电流设定 500mA Note: Charging current 500mA</p>	见表 1 Refer to TABLE-1

名称 Name	规格书 Specification	
版本 Version	03	页数 Page
标准指南 Standard Manual		4

5.1.5	等效串联电阻 ESR	测试频率: 100kHz 测试温度: 20 ±2°C 测量位置: ESR测量时应夹取引线根部 Measuring frequency: 100kHz ; Measuring temperature: 20 ±2°C ; Measuring point : clamped at the root of the lead wire	Refer to TABLE-1
-------	---------------	---	-------------------------

5.2 机械特性 MECHANICAL PERFORMANCE

序号 NO	项目 Item	测试方法 Test method	特性 Performance																								
5.2.1	端子强度 Terminal strength	<p>① 端子抗拉强度Tensile strength of terminals: 沿电容器端子引线方向施加拉力(如下表), 持续时间30±1s ; Apply a tensile force along the lead direction of the capacitor terminal (as shown in the following table) for 30±1s.</p> <table border="1" style="width:100%; border-collapse: collapse; margin-bottom: 10px;"> <tr> <td style="text-align: center;">引线直径 Φ(mm)</td> <td style="text-align: center;">0.45</td> <td style="text-align: center;">0.5</td> <td style="text-align: center;">0.6</td> <td style="text-align: center;">0.8</td> <td style="text-align: center;">1.0</td> </tr> <tr> <td style="text-align: center;">拉力 (N)</td> <td style="text-align: center;">5N</td> <td style="text-align: center;">5N</td> <td style="text-align: center;">10N</td> <td style="text-align: center;">10N</td> <td style="text-align: center;">25N</td> </tr> </table> <p>②端子抗弯强度Bending strength of termination: 在电容器引线施加固定重力(如下表), 然后, 将电容器弯折90°后回到原位, 再向相反方向弯折90°后回到原位。上述过程在5秒内完成。 Apply fixed gravity to the capacitor lead (as shown in the following table), then bend the capacitor 90° and return to its original position, and then bend it 90° in the opposite direction and return to its original position. The above process is completed in 5 seconds.</p> <table border="1" style="width:100%; border-collapse: collapse;"> <tr> <td style="text-align: center;">引线直径 Φ(mm)</td> <td style="text-align: center;">0.45</td> <td style="text-align: center;">0.5</td> <td style="text-align: center;">0.6</td> <td style="text-align: center;">0.8</td> <td style="text-align: center;">1.0</td> </tr> <tr> <td style="text-align: center;">拉力 (N)</td> <td style="text-align: center;">2.5N</td> <td style="text-align: center;">2.5N</td> <td style="text-align: center;">5N</td> <td style="text-align: center;">5N</td> <td style="text-align: center;">10N</td> </tr> </table>	引线直径 Φ(mm)	0.45	0.5	0.6	0.8	1.0	拉力 (N)	5N	5N	10N	10N	25N	引线直径 Φ(mm)	0.45	0.5	0.6	0.8	1.0	拉力 (N)	2.5N	2.5N	5N	5N	10N	容量变化:在初始值的±5%以内; DF:≤规定值的 130%; ESR:≤规定值的 130%; 漏电流:≤规定值; 外观: 无可见机械损伤 Variation of capacitance: Within ±5% of the initial value Dissipation factor: ≤ 130% of the specified value ESR: ≤ 130% of the specified value Leakage current: ≤ specified value; Appearance: No visible mechanical damage.
引线直径 Φ(mm)	0.45	0.5	0.6	0.8	1.0																						
拉力 (N)	5N	5N	10N	10N	25N																						
引线直径 Φ(mm)	0.45	0.5	0.6	0.8	1.0																						
拉力 (N)	2.5N	2.5N	5N	5N	10N																						

5.2.2	振动试验 Resistance to Vibration	频率范围: 10赫兹~55赫兹~10赫兹 (1分钟内) ; 峰值加速度: 5g ; 方位:X、Y、Z; ; 每个方位120分钟(总共6小时); Frequency range: 10 Hz ~55 Hz ~10 Hz (within 1 minute); Peak acceleration: 5g ; Orientation: x, y, z ; 120 minutes for each orientation (6 hours in total);	容量变化:在初始值的±5%以内 外观: 无可见机械损伤 Variation of capacitance: Within ±5% of the initial value Appearance: No visible mechanical damage.
5.2.3	可焊性 Solder ability	温度: 235 ± 5 °C 持续时间: 2 ± 0.5秒 焊料:25wt%的松香(JIS K5902)//乙醇(JIS K 8101) Temperature : 235 ± 5 °C Duration : 2 ± 0.5 seconds Flux:Rosin (JIS K5902)//Ethanol(JIS K8101); About 25 wt.%	浸入焊锡的引线表面积约95%以上应附着 新锡 At least 95% of surface area of the dipped portion of the terminal shall be covered with new solder.

5.3 耐久性测试 ENDURANCE PERFORMANCE

序号 NO	项目 Item	测试方法 Test method	特性 Performance
5.3.1	耐焊接热 Resistance to soldering heat	焊槽法: 焊锡温度: 260±5°C 浸入时间: 10±1 秒 外露引线长度不超过 1.0mm Solder bath method Solder temperature : 260±5°C Immersion time : 10±1sec. The exposed lead length shall not exceed 1.0mm	容量变化:在初始值的±5%以内 损耗角正切值:≤规定值的 130% 阻抗:≤规定值的 130% 漏电流:≤规定值 Variation of capacitance: Within ±5% of the initial value Dissipation factor: ≤ 130% of the specified value ESR: ≤ 130% of the specified value Leakage current: ≤ specified value

5.3.2	稳态湿热 Resistance to damp heat (steady state)	试验温度: $60\pm 2^{\circ}\text{C}$ 相对湿度: 90~95 % R.H. 试验时间: 1000 (-0/+48)h 不施加电压 试验后, 电容器在标准大气条件下 1~2 小时, 后测试参数 Test temperature : $60\pm 2^{\circ}\text{C}$ Relative humidity: 90~95% R.H. Test time : 1000 (-0/+48) h No voltage applied After completion of test, the capacitors shall be subjected to standard atmospheric conditions for 1 to 2 hours, after which measurements shall be made.	电容变化在初始值的 $\pm 20\%$ 内 损失角 \leq 规格值的150% 等效串联电阻 \leq 规格值的150% 漏电流 \leq 规格值(电压处理后测试漏电流) Capacitance change within $\pm 20\%$ of initial value $\tan \delta \leq 150\%$ of the initial specified value. $\text{ESR} \leq 150\%$ of the initial specified value. Leakage current \leq initial specified value (after voltage treatment).
5.3.3	高温负荷试验 Load life test	试验温度: $105\pm 2^{\circ}\text{C}$, 施加额定电压 符号寿命: 2000H Test temperature: $105\pm 2^{\circ}\text{C}$ Apply rated voltage. Load life: 2000H	容量变化: 在初始值的 $\pm 20\%$ 内; 损失角: 小于规格值的150%; 等效串联电阻 \leq 规格值的150%; 漏电流 \leq 规格值 ; 外观: 没有明显的损伤 Variation of capacitance: within $\pm 20\%$ of the initial value $\tan \delta \leq 150\%$ of the initial specified value. $\text{ESR} \leq 150\%$ of the initial specified value. Leakage current \leq initial specified value. Appearance:No significant damage
5.3.4	快速变温 Rapid change of temperature	TA = 下限类别温度, TB = 上限类别温度; 在TA或TB的持续时间: 30分钟; TA与TB间转换时间: 1分钟之内; 循环次数: 5次 ; 试验结束至少放置16小时, 或让电容恢复至 20°C , 观察电容外观 及测量。 TA=Lower bound category temperature, TB=Upper limit category temperature; Duration in TA or TB: 30 minutes; Conversion time between TA and TB: Within a minute; Cycle number: 5 Cycles the measurements shall be measured after 16 hours or restore the capacitor to 20°C	容量变化: 在初始值的 $\pm 10\%$ 内 损失角: 小于或等于规格值 漏电流: 小于或等于规格值 Capacitance change : Within $\pm 10\%$ of the initial capacitance ; $\tan \delta \leq$ initial specified value. Leakage current : \leq initial specified value.

名称	Name	规格书 Specification		
版本	Version	03	页数 Page	7
标准指南 Standard Manual				

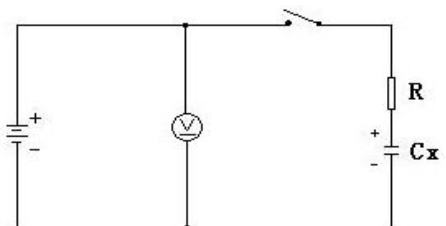
<p>5.3.5</p>	<p>耐浪涌电压 Surge Test</p>	<p>对电容施加额定浪涌电压，充电 30 ± 5 秒，放电 5.5 ± 0.5 分钟作为一个周期，共进行 1000 次。测试回路如下图。然后在标准大气条件下放置达到热稳定，测试各参数。测试温度：$15^{\circ}\text{C} \sim 35^{\circ}\text{C}$；</p> <p>Rated surge voltage shall be applied (switch on) for 30 seconds and then shall be applied (switch off) with discharge for 5min30 seconds at room temperature . This cycle shall be repeated for 1000 cycles .</p> <p>Duration of one cycle is 6 minutes . Test temperature: $15^{\circ}\text{C} \sim 35^{\circ}\text{C}$</p> <p>The test circuit is as follows:</p>  <p>浪涌电压设定 (Surge Voltage setting) :</p> <table border="1" data-bbox="443 1093 1061 1265"> <tr> <td>RV(V)</td> <td>6.3</td> <td>7.5</td> <td>10</td> <td>12</td> <td>16</td> <td>25</td> </tr> <tr> <td>S.V(V)</td> <td>7.2</td> <td>8.6</td> <td>11.5</td> <td>13.8</td> <td>18.4</td> <td>28.8</td> </tr> <tr> <td>RV(V)</td> <td>35</td> <td>50</td> <td>63</td> <td>80</td> <td>100</td> <td></td> </tr> <tr> <td>S.V(V)</td> <td>41</td> <td>58</td> <td>73</td> <td>92</td> <td>115</td> <td></td> </tr> </table>	RV(V)	6.3	7.5	10	12	16	25	S.V(V)	7.2	8.6	11.5	13.8	18.4	28.8	RV(V)	35	50	63	80	100		S.V(V)	41	58	73	92	115		<p>容量变化：在初始值的$\pm 20\%$以内 损耗角正切值：\leq规定值的 150% 阻抗：\leq规定值的 150% 漏电流：\leq规定值</p> <p>Variation of capacitance: Within $\pm 20\%$ of the initial value Dissipation factor: $\leq 150\%$ of the specified value ESR: $\leq 150\%$ of the specified value Leakage current: \leqspecified value</p>
RV(V)	6.3	7.5	10	12	16	25																									
S.V(V)	7.2	8.6	11.5	13.8	18.4	28.8																									
RV(V)	35	50	63	80	100																										
S.V(V)	41	58	73	92	115																										
<p>5.3.6</p>	<p>温度特性 Temperature Characteristic</p>	<table border="1" data-bbox="443 1348 1061 1478"> <thead> <tr> <th>阶段</th> <th>温度</th> <th>时间</th> </tr> </thead> <tbody> <tr> <td>1</td> <td>$20 \pm 2^{\circ}\text{C}$</td> <td>30min</td> </tr> <tr> <td>2</td> <td>$-55 + 0 / - 3^{\circ}\text{C}$(下限类别温度 T_B)</td> <td>120min</td> </tr> </tbody> </table>	阶段	温度	时间	1	$20 \pm 2^{\circ}\text{C}$	30min	2	$-55 + 0 / - 3^{\circ}\text{C}$ (下限类别温度 T_B)	120min	<table border="1" data-bbox="1085 1348 1524 1467"> <thead> <tr> <th>项目</th> <th>性能</th> </tr> <tr> <th>Item</th> <th>Performance</th> </tr> </thead> <tbody> <tr> <td>Z (-55°C) / Z ($+20^{\circ}\text{C}$)</td> <td>≤ 2.5</td> </tr> </tbody> </table>	项目	性能	Item	Performance	Z (-55°C) / Z ($+20^{\circ}\text{C}$)	≤ 2.5													
阶段	温度	时间																													
1	$20 \pm 2^{\circ}\text{C}$	30min																													
2	$-55 + 0 / - 3^{\circ}\text{C}$ (下限类别温度 T_B)	120min																													
项目	性能																														
Item	Performance																														
Z (-55°C) / Z ($+20^{\circ}\text{C}$)	≤ 2.5																														
<p>5.3.7</p>	<p>纹波电流 频率修正系数 frequency correction coefficient of Ripple current</p>	<table border="1" data-bbox="491 1684 1481 1780"> <thead> <tr> <th>频率 (Hz)</th> <th>120</th> <th>1K</th> <th>10K</th> <th>100K</th> <th>500K</th> </tr> </thead> <tbody> <tr> <td>修正因子</td> <td>0.05</td> <td>0.30</td> <td>0.70</td> <td>1.00</td> <td>1.00</td> </tr> </tbody> </table>	频率 (Hz)	120	1K	10K	100K	500K	修正因子	0.05	0.30	0.70	1.00	1.00																	
频率 (Hz)	120	1K	10K	100K	500K																										
修正因子	0.05	0.30	0.70	1.00	1.00																										

6. 标记 MARKING

6.1 在电容器体上清晰注明有如下内容: Capacitor shall be clearly marked on it' s body.

6.1.1 额定静容量 额定电容 Rated Capacitance

6.1.2 额定工作电压额定电压 Rated voltage

6.1.3 系列 Series

6.1.4 负极标示 Negative Polarity

6.1.5 生产日期 Date of production

6.1.6 系列编码 Series code



系列 series	VP1	VPX	VPT	VPL	VPH	VPM	VPG	VPS	VGY	VHT
	NP1	NPX	NPT	NPL	NPH	NPM	NPG	NPS	NGY	NHT
编码 code	P1	PX	PT	PL	PH	PM	PG	PS	GY	HT

6.1.7 年份编码 Year Code

年份 Year	2013	2014	2015	2016	2017	2018	2019	2020	2021	2022	...	2038
编码 Code	A	B	C	D	E	F	G	H	J	K	...	Z

6.1.8 月份编码 Month code

月份 Month	1	2	3	4	5	6	7	8	9	10	11	12
编码 Code	A	B	C	D	E	F	G	H	J	K	L	M

7. 包装 package

7.1 包装标签 PACKING LABEL

包装标签包括以下内容 Packing Label Marked (the following items shall be marked on the label)

- 1) 产品名称 Product name
- 2) 生产批号 Lot No
- 3) 数量 quantity
- 4) 生产日期 Production date
- 5) 产品编号 Part No
- 6) 客户物料描述 Customer item code

标签示例

		Certification 合格证		
Product name: 产品名称	VP4_16V_82μF_6.3*3.95_-20% +20%_涂膜铝壳			
LOT NO: 生产批号		QTY: 数量	1	PCS
Production date: 生产日期	2021-08-2	Product No: 产品编号	642064	
Customer Item Code 客户物料描述 无				

7) 批号 Lot number:

1	2	3	4	5	6	7	8	9	10	11	12	13
永铭 YM		年 year		月 month		材料标识 material code	生产序号 production number			流水号 serial number		

名称	Name	规格书		Specification
版本	Version	03	页数	Page
		标准指南	Standard Manual	9

7.2 包装箱 Bulk Packing

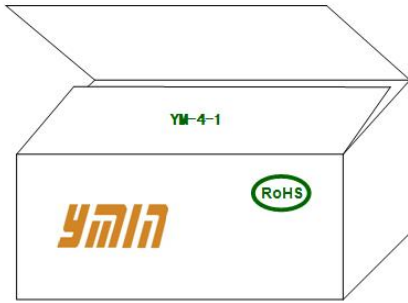

内包装盒 Box



外包装箱 Carton

8、引脚成型和编带：Forming and Taping:

8.1 引脚成型 Forming

加工类别 Type	图样 Cutting&Forming	尺寸 Size																												
引线切脚 A 图		<table border="1"> <thead> <tr> <th>项目</th> <th>公差</th> <th colspan="5">尺寸</th> </tr> </thead> <tbody> <tr> <td>D</td> <td>/</td> <td>5</td> <td>6.3</td> <td>8</td> <td>10/12.5</td> <td>16/18</td> </tr> <tr> <td>F</td> <td>±0.5</td> <td>2.0</td> <td>2.5</td> <td>3.5</td> <td>5.0</td> <td>7.5</td> </tr> <tr> <td>B</td> <td>±0.5</td> <td colspan="5">2.5 ~ 10</td> </tr> </tbody> </table>	项目	公差	尺寸					D	/	5	6.3	8	10/12.5	16/18	F	±0.5	2.0	2.5	3.5	5.0	7.5	B	±0.5	2.5 ~ 10				
项目	公差	尺寸																												
D	/	5	6.3	8	10/12.5	16/18																								
F	±0.5	2.0	2.5	3.5	5.0	7.5																								
B	±0.5	2.5 ~ 10																												
引线切脚成型 B 图 (外 K)		<table border="1"> <thead> <tr> <th>项目</th> <th>公差</th> <th>尺寸</th> </tr> </thead> <tbody> <tr> <td>D</td> <td>/</td> <td>≤12.5</td> </tr> <tr> <td>A</td> <td>/</td> <td>≤25</td> </tr> <tr> <td>L</td> <td>±0.5</td> <td>2.5 ~ 22</td> </tr> <tr> <td>K</td> <td>±0.5</td> <td>2.5</td> </tr> <tr> <td>L2</td> <td>±0.3</td> <td>1.5</td> </tr> <tr> <td>L</td> <td>±0.5</td> <td>2.0 ~ 5.0</td> </tr> </tbody> </table>	项目	公差	尺寸	D	/	≤12.5	A	/	≤25	L	±0.5	2.5 ~ 22	K	±0.5	2.5	L2	±0.3	1.5	L	±0.5	2.0 ~ 5.0							
项目	公差	尺寸																												
D	/	≤12.5																												
A	/	≤25																												
L	±0.5	2.5 ~ 22																												
K	±0.5	2.5																												
L2	±0.3	1.5																												
L	±0.5	2.0 ~ 5.0																												
引线切脚成型 C 图 (内外 K)		<table border="1"> <thead> <tr> <th>项目</th> <th>公差</th> <th>尺寸</th> </tr> </thead> <tbody> <tr> <td>D</td> <td>/</td> <td>≤Φ12.5</td> </tr> <tr> <td>A</td> <td>/</td> <td>≤25</td> </tr> <tr> <td>C</td> <td>±0.5</td> <td>2.5 ~ 22</td> </tr> <tr> <td>B</td> <td>±0.5</td> <td>3</td> </tr> <tr> <td>E</td> <td>±0.3</td> <td>1.2</td> </tr> <tr> <td>F</td> <td>±0.3</td> <td>1.8</td> </tr> <tr> <td>G</td> <td>±0.3</td> <td>0.8</td> </tr> <tr> <td>H</td> <td>±0.5</td> <td>2.0 ~ 5.0</td> </tr> </tbody> </table>	项目	公差	尺寸	D	/	≤Φ12.5	A	/	≤25	C	±0.5	2.5 ~ 22	B	±0.5	3	E	±0.3	1.2	F	±0.3	1.8	G	±0.3	0.8	H	±0.5	2.0 ~ 5.0	
项目	公差	尺寸																												
D	/	≤Φ12.5																												
A	/	≤25																												
C	±0.5	2.5 ~ 22																												
B	±0.5	3																												
E	±0.3	1.2																												
F	±0.3	1.8																												
G	±0.3	0.8																												
H	±0.5	2.0 ~ 5.0																												

名称	Name	规格书			Specification
版本	Version	03	页数	Page	10
标准指南		Standard Manual			

引线切脚成
型 D 图

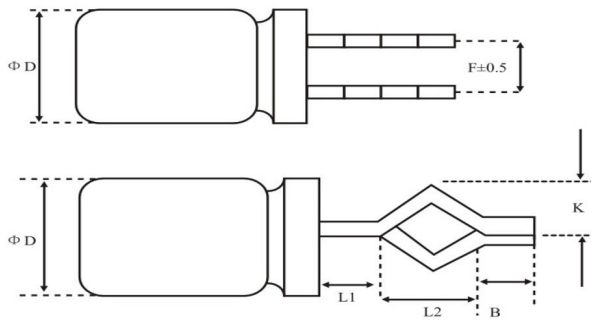

项目	公差	尺寸
ϕD	/	8
F	± 0.5	3.5
L1	± 0.5	2.5~21.0
L2	± 0.5	3.5
K	± 0.2	1.2

引线切脚成
型 E 图

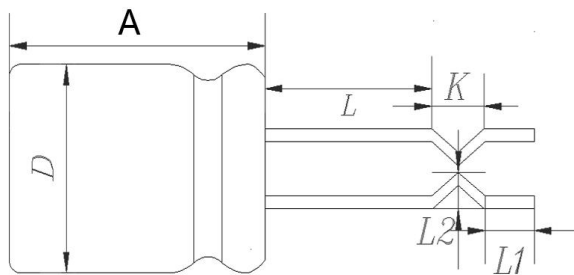

项目	公差	尺寸
D	/	$\leq \phi 12.5$
A	/	≤ 25
$L \pm 0.5$	± 0.5	2.5~22
$K \pm 0.5$	± 0.5	2.5
$L2 \pm 0.3$	± 0.3	1.5
$L1 \pm 0.5$	± 0.5	2.0~5.0

引线切脚成
型 F 图 (成
型折弯 90°)

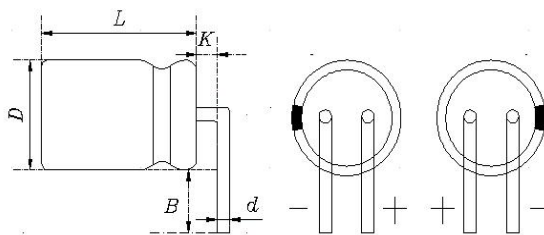

项目	公差	尺寸	
		D	/
K	± 0.5	2.0	2.5
B	± 0.5	2.0~10.0	
类型	/	右弯 A 型/左弯 B 型	

引线切脚成
型 G 图

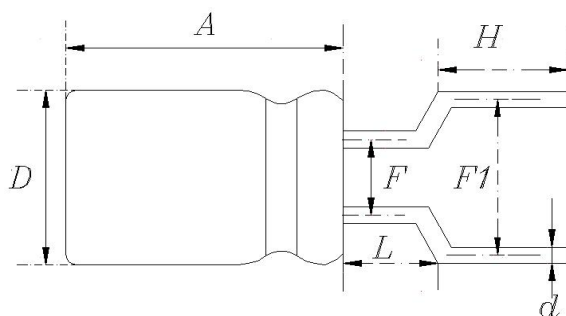

项目	公差	尺寸						
		D	/	$\phi 5$	$\phi 6.3$	$\phi 8$		
L	± 0.5	2.5	2.5	2.5				
H	± 0.5	2.0~10.0						
F	± 0.5	2.0	2.0	2.0	2.5	2.5	3.5	
F1	± 0.5	2.5	3.5	5	3.5	5	5	

引线切脚成
型 H 图 (成型
双折弯 90°)

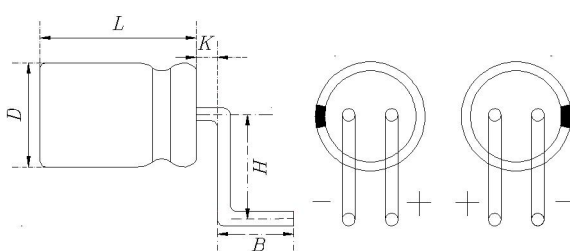

项目	公差	尺寸				
		D	/	$\phi 5$	$\phi 6.3$	$\phi 8$
K	± 0.5	2.0	2.0	2.0	2.0	2.0
H	± 0.5	7.0	7.0	7.0	7.0	7.0
B	± 0.5	2.0~10.0				
类型	/	右弯 A 型/左弯 B 型				

名称 Name

规格书 Specification

版本 Version

03

页数 Page

11

标准指南

Standard Manual

8.2 编带 Taping

编带外型尺寸 A 图 Taping A :

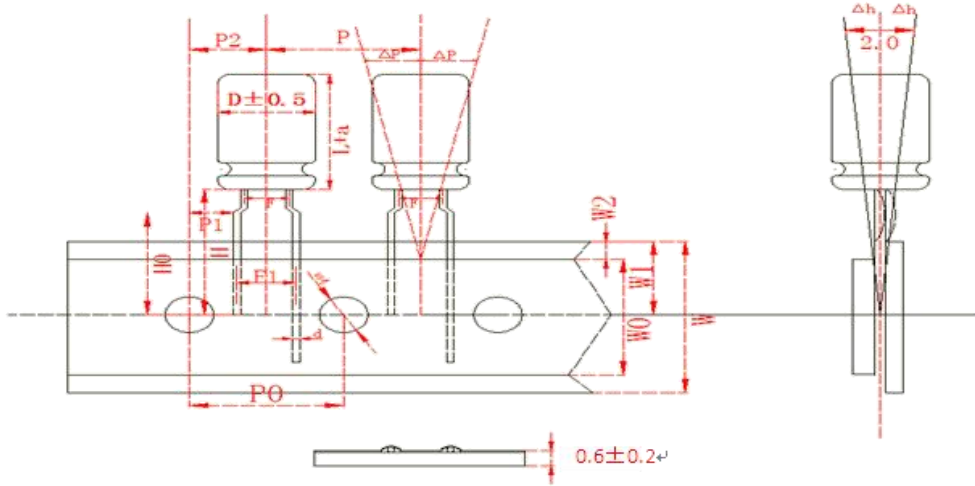

编带外型尺寸 B 图 Taping B ($\Phi 5 \sim \Phi 8$)

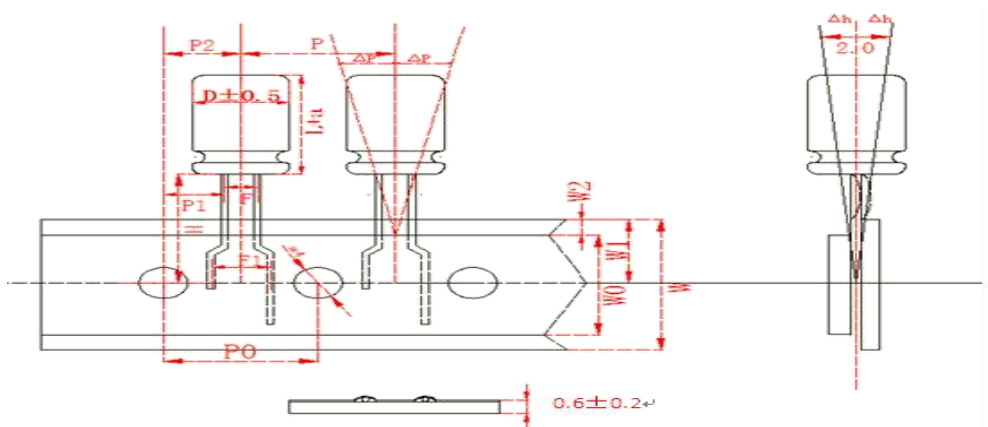

编带外型尺寸 B 图 Taping B - $\Phi 10 \sim \Phi 12.5$

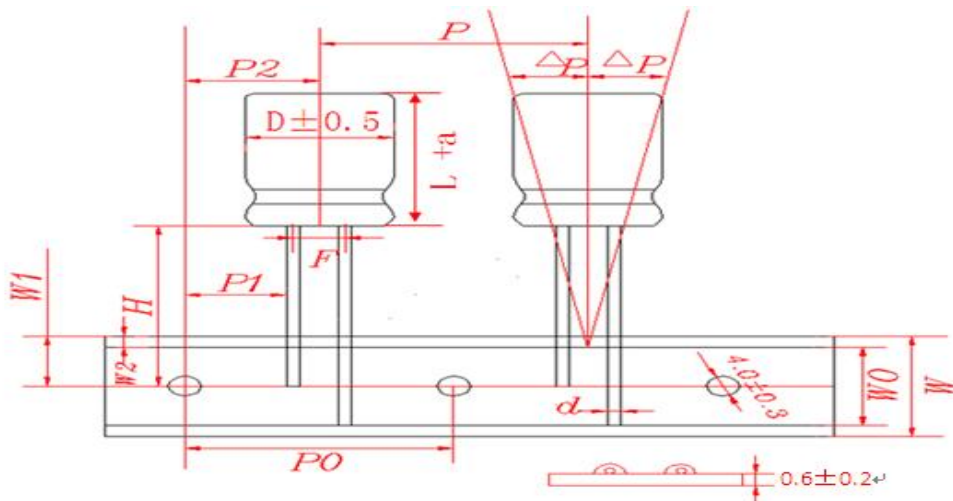

名称	Name		规格书	Specification	
版本	Version	03	页数	Page	12
标准指南		Standard Manual			

编带规格表 Specification Information:

项目	记号	Φ5				Φ6.3		Φ8		Φ10	Φ12.5	允许差
引线加工记号		U1	U4	U5	T1	U2	T2	U3	T3	T4	T5	/
形状尺寸图		图 A	图 A	图 A	图 B	图 A	图 B	图 A	图 B	图 B	图 B	/
引线直径	Φd	0.5					0.6					±0.05
主体间距	P	12.7								15	±1.0	
穿孔间距	P0	12.7								15	±0.2	
穿孔与引线间距	P1	3.85			4.35	3.85	4.35	3.85	4.35	5	±0.7	
穿孔与主体间距	P2	6.35								7.5	±1.0	
引线间距	F1	5.0	2.5	3.5	5.0	5.0	5.0	5.0	5.0	5.0	+0.8~-0.2	
引线间距	F	2.0				2.5		3.5		5.0	±0.5	
衬纸宽度	W	18.0								±0.3		
胶带宽度	W0	12.5								MIN		
穿孔与衬纸间距	W1	9.0								±0.5		
胶带与衬纸间距	W2	0.5~2.0								/		
主体下方位置	H	18.5								±0.75		
引线弯曲高度	H0	16		--	16	--	16	--			±0.5	
穿孔直径	ΦD0	4.0								±0.3		
主体倾斜度	Δh	1.0								MAX		
主体倾斜度	Δp	1.0								MAX		
编带总厚度	t	0.6								±0.2		
最小包装数量	Pcs	2100				1700		1000		672	440	

上海永铭电子

ShangHai Yongming
Electronic Co.,Ltd.

固体铝电解电容器规格书

Conductive Polymer Aluminun Solid
Electrolytic Capacitors



9、产品编码规则 Product Code Rules

编码序号	1	2	3	4	5	6	7	8	9	10	11	12	13	14	15	16	17	18	19	20	21	22	1-22组合
编码说明	产品系列编码			直径编码	高度编码			额定工作电压编码		额定容量编码			容量范围编码	引脚成型/编带编码	丝印或套管编码 注：车规可留空		应用类别编码 注：消费类可留空		补充要求编码 注：无特殊要求可留空		客户定制编码 末位1和末位2注：可留空		完整编码示例
编码示例1	N	P	M	A	1	1	0	1	E	1	0	1	K	P	T	M	L	G	K	Z	H	H	NPMA1101E101KPTMLGKZHH
编码示例2	V	P	X	C	0	5	8	1	V	1	0	1	M	V	T	M					H	H	VPXC0581V101MVTMHH
编码示例3	V	H	X	C	0	5	8	1	V	1	0	1	M	V			C	G			7	T	VHXC0581V101MVG7T
编码示例4	N	P	X	L	2	5	0	1	K	2	2	2	M	J	J	G	J	P					NPXL2501K222MJGJP

产品系列编码		额定容量编码				产品尺寸编码				容量范围编码	
系列	编码	容量	编码	容量	编码	直径	编码	高度	编码	容量范围	编码
NP1	NP1	1.0	1R0	180	181	3.55	W	3.55	035	±20%	M
NPX	NPX	1.5	1R5	220	21	4	A	3.95	039	±10%	K
NPH	NPH	2.2	2R2	270	271	4.5	G	4.5	045	引脚成型/编带编码	
NPT	NPT	2.7	2R7	330	331	5	B	5	050	F	引线 22F27F
NPL	NPL	3.3	3R3	390	391	5.5	H	5.4	054	A	切脚成型 A 图
VP1	VP1	4.7	4R7	470	471	6.3	C	5.8	058	B	切脚成型 B 图
VPX	VPX	5.6	5R6	560	561	8	D	6.5	065	C	切脚成型 C 图
VPH	VPH	6.8	6R8	680	681	10	E	7	070	D	切脚成型 D 图
VPT	VPT	8.2	8R2	820	821	12.5	L	7.7	077	E	切脚成型 E 图
VPL	VPL	10	100	1000	102	16	I	8	080	Q	切脚折弯 90°F 图 A 型 (右)
		12	120	1200	122	18	J	8.5	085	P	切脚折弯 90°F 图 B 型 (左)
额定工作电压编码		15	150	1500	152	20	N	9	090	X	切脚成型 G 图
电压	编码	18	180	1800	182	22	K	9.5	095	G	切脚双折弯 90°H 图 A 型 (右)
2.0V	0D	22	220	2000	202	25	M	10	100	R	切脚双折弯 90°H 图 B 型 (左)
2.5V	0E	27	270	2200	222	30	P	10.5	105	K	编带 A 图
4.0V	0G	33	330	2500	252			11	110	L	编带 B 图
6.3V	0J	39	390	2700	272			11.5	115	V	SMD
6.8V	0A	47	470	3300	332			12	120	J	固态引线型
7.5V	0L	56	560	3900	392			12.5	125	O	引线 30F/35F
10V	1A	68	680	4700	472			13	130	H	引线 33F/38F
12V	1B	82	820	5600	562			13.5	135	T	剪脚 (长短脚)
16V	1C	100	101	6800	682			14	140	丝印或套管编码	
25V	1E	120	121	8200	822			14.5	145	JG	套管
20V	1D	150	151	10000	103			15	150	TM	涂膜丝印
35V	1V									应用类别编码	
50V	1H							16	160	CG	车规
63V	1J							16.5	165	LG	雷管
80V	1K							17	170	JP	军品
100V	2A							18	180	GY	工业
125V	2B							19	190		
160V	2C							20	200	特殊要求编码	
200V	2D							25	250	KZ	抗震
250V	2E							31.5	315		
								35.5	355	客户定制编码 (末位码 1 和末位码 2)	
										□□	客户定制码, 由客户指定

名称	Name	规格书		Specification
版本	Version	03	页数	Page
			14	
标准指南		Standard Manual		

10. 其他 The others

10.1 铝电解电容器的应用上的重要信息

Important information on the application of Aluminum Electrolytic Capacitors .

10.1.1. 极性 Polarity

电容器是有极性的，请勿施加反向电压或交流电压。极性接反会导致电容漏电流上升、甚至短路或防爆阀打开。

电容器的极性确认，请参见目录或产品规格中的相关图表，或电容器本体上的极性标记。

Capacitors are polarized. Never apply a reverse voltage or AC voltage. Connecting with wrong polarity will short-circuit or damage the capacitor with the pressure relief vent opening early on. To identify the polarity of a capacitor, see the relevant diagram in the catalogs or product specifications, or the polarity marking on the body of the capacitors.

10.1.2. 施加电压 Operating voltage

电容器工作电压不应超过额定电压；施加电压若超过额定电压，将可能造成漏电流上升甚至短路；

电容器上设定了额定电压。请将和直流电压重叠的纹波电压的峰值设定在额定电压以下。

在工作温度范围内，无论环境温度是多少度，都可以在额定电压以下使用，不需要降低电压。

Do not apply an over-voltage that exceeds a rated voltage specified for the capacitors. If the applied voltage exceeds the rated voltage, it may cause leakage current to rise or even short circuit.

The total peak value of the ripple voltage plus the DC voltage must not exceed the rated voltage of the capacitors. Capacitors do not require voltage derating within the category temperature.

10.1.3. 快速充放电 Rapid charge and discharge

常规电容器请勿使用于急速充放电的电路中。急速充放电可能造成电容短路、漏电增大及容量衰减，如果需要对电容进行高频次急速充放电或者高频次的深度充放电（短路放电和充），请联系我们。

Do not use conventional capacitors in circuits with rapid charge and discharge. Rapid charge and discharge may cause capacitor short circuit, increased leakage and capacity attenuation. If it is necessary to charge and discharge the capacitor rapidly at high frequency or deep charge and discharge at high frequency (short circuit discharge and charge), please contact us.

10.1.4. 存储电容器 Store the capacitors.

请保管在室温5 ~ 35°C、湿度75% 以下的环境。请尽量以包装状态保管。保管期限：原则上为制造后 2 年以内。

请避免在以下环境下保管：

- ① 溅水、高温高湿及结露的环境；
- ② 溅油、或者充满气体油成分的环境；
- ③ 溅盐水、充满盐分的环境；
- ④ 充满酸性有毒气体(硫化氢、亚硫酸、亚硝酸、氯、溴、溴；
- ⑤ 充满氨气等碱性有毒气体的环境；
- ⑥ 酸性及碱性溶剂的环境；
- ⑦ 直射阳光、臭氧、紫外线及放射线照射的环境。化甲烷等) 的环境；
- ⑧ 不可保管在使电容器受到振动、冲击的环境下；
- ⑨ 存放时间超过3年的电解电容器应报废处理；

名称	Name	规格书			Specification
版本	Version	03	页数	Page	15
		标准指南	Standard Manual		

Store the capacitors indoors at temperatures of 5 to 35°C and humidities of less than 75%RH. In principle, aluminum electrolytic capacitors should be used within one year after production. Keep capacitors packed in the original packaging material wherever possible.

Avoid the following storage environmental conditions:

- ① Water spattering, high temperatures, high humidity or condensation environment.
- ② Oil spattering or oil mist filled.
- ③ Salt water spattering or salt filled.
- ④ Acidic toxic gases such as hydrogen sulfide, sulfuric acid, nitrous acid, chlorine, bromine and methyl bromide filled.
- ⑤ Alkaline toxic gases such as ammonium filled.
- ⑥ Acid or alkaline solutions spattering.
- ⑦ Direct sunlight, ozone, ultraviolet rays or radiation.
- ⑧ Extreme vibration or shock loading.
- ⑨ Electrolytic capacitors stored for more than 3 years shall be discarded.

10.1.5 纹波电流 Ripple current

请不要加载超大电流(超过额定纹波电流的电流)。

施加过大的纹波电流时,会使电容内部发热变大,温度上升,寿命变短甚至引起短路。

施加额定纹波电流时,请保持足够的直流偏置电压,避免造成反向电压的情况。

额定纹波电流的频率是100KHz,在其它频率下使用时,要控制在乘以各系列规定的频率修正系数的值以下。

Do not apply an over ripple current that exceeds the rated ripple current specified for the capacitors.. When excessive ripple current is applied, the internal heat generation of the capacitor will increase, the temperature will rise, and the life will be shortened. Even cause short circuit. When applying rated ripple current, please keep enough DC bias voltage to avoid reverse voltage. The frequency of rated ripple current is 100KHz, and when used at other frequencies, it should be controlled below the value multiplied by the frequency correction coefficient specified in each series.

10.1.6. 使用温度 Operating temperature

请不要在高温(超过工作上限温度的温度)下使用。如果超过工作上限温度使用,电容器的寿命会缩短,并可能导致压力阀动作等破损。

使用温度的关注内容不仅限于环境温度及机器内的温度,还需要确认电容附近的发热体(晶体管、电阻等)的辐射热、包括纹波电流自身发热等。如果使用温度降低,寿命会延长。

Please do not use the capacitors at high temperature (temperature exceeding the upper working limit).

If it is used above the upper working temperature, the life of the capacitor will be shortened, which may lead to damage such as pressure valve operation. The attention of using temperature is not limited to the ambient temperature and the temperature in the machine, but also needs to confirm the radiant heat of the heating elements (transistors, resistors, etc.) near the capacitor, including the self-heating of ripple current, etc. If the service temperature is lowered, the service life will be prolonged.

10.1.7. 电容器的故障模式 Fault mode of capacitor

非固体铝电解电容器是有使用寿命的零件,在一般情况下会表现为开路型故障模式。

产品及使用条件的不同有时会同时引发压力阀动作等的故障。

名称	Name	规格书			Specification
版本	Version	03	页数	Page	16
		标准指南	Standard Manual		

但是，在过电压或过电流等超过保证范围的负荷条件使用电容时，电容器也有可能发生短路模式故障。电容器故障模式取决于导致故障的应用条件。

Non-solid aluminum electrolytic capacitor is a part with long service life, which usually shows an open-circuit failure mode. As well as the difference of product use conditions, sometimes faults such as pressure valve action will be caused at the same time. However, it also may lead to short circuit mode failure when capacitor is used in the overload more than the guarantee ranges including over voltage and the over current. Failure modes depend on the application conditions that lead to fail.

10.1.8 电容器的绝缘

电容器的铝壳未保证绝缘。外部包装层作为标识之用，不保证电气绝缘功能；电容器的外壳和阴极端子及阳极端子和电路型板请进行电气绝缘。

The can case of capacitor does not assure electrical insulation. The outer coating on can case is aimed for indication and does not assure function of the electrical insulation.

Electrically isolate the outer can case of a capacitor from the negative terminal, the positive terminal and circuit patterns.

10.1.9 焊接和安装 soldering and Assembling

焊接条件要在承认书的规定范围内。若没有遵守承认书的条件，则电容漏电流可能急剧增加，容量衰减。

安装注意事项：

- ①已经成套组装并通过电的电容器请勿再次使用；
- ②铝电解电容器可能存在一定的再生电压，因此电容器使用前请用1kΩ左右的电阻器进行放电处理；
- ③在超过室温35℃、湿度75%RH的条件下，超过产品目录或规格说明书的规定期限进行长期保管时，电容器的漏电流有可能增大。此时，请对电容器进行电压处理（105℃，额定电压及串联1 kΩ电阻保护，充电2小时）；
- ④安装前请确认电容器的额定规格（静电容量及额定电压）；
- ⑤安装前请确认电容器的极性；
- ⑥请勿使用跌落过电容器；
- ⑦安装时请勿使电容器变形；
- ⑧安装前请确认电容器的端子间隔和印刷线路板的孔间距尺寸一致；
- ⑨机器设备自动化生产过程中，电容器在吸附、装配及位置对准时，或者对电容器引线进行加工时，电容器有可能受到超出允许范围的应力，请控制电容器受到的外力。

The soldering conditions are to be within the range prescribed in specifications. If the specifications are not followed, there is a possibility of the cosmetic deflection, the intensive increase of leakage current, and the capacitance reduction.

Precautions for Assembling:

- ① Do not reuse the capacitors that have been assembled in complete sets and passed electricity;
- ② The aluminum electrolytic capacitor may have a certain regeneration voltage, so please use a resistor of 1kw to discharge the capacitor before use;
- ③ The leakage current of the capacitor may increase when it is stored for a long time beyond the specified time limit in the catalogue or specification under the conditions of exceeding room temperature 35℃ and humidity 75%RH. At this time, please conduct voltage treatment on the capacitor. (105℃, rated voltage and 1 kΩ resistance protection in series, charging for 2 hours) .
- ④ Please confirm the rated specifications (electrostatic capacity and rated voltage) of the capacitor before

名称	Name	规格书			Specification
版本	Version	03	页数	Page	17
标准指南		Standard Manual			

installation;

- ⑤ Please confirm the polarity of the capacitor before installation;
- ⑥ Do not use dropped capacitors;
- ⑦ Do not deform the capacitor during installation;
- ⑧ Before installation, please confirm that the terminal spacing of capacitor is consistent with the hole spacing of printed circuit board.
- ⑨ During the automatic production of machinery and equipment, when the capacitor is adsorbed, assembled and aligned, or when the capacitor leads are processed, the capacitor may be stressed beyond the allowable range. Please control the external force on the capacitor.

焊接后处理Handling after soldering :

印刷配线板焊接后的处理注意不可施加以下机械应力:

- ①电容器主体不可倾斜、倒地或扭曲;
- ②不可抓住电容器的主体搬运电路板;
- ③不可让其他物体碰撞到电容器。此外，当重叠放置印刷配线板时，不可使印刷配线板或其他零件碰到电容器。
- ④安装好电容器的印刷电路板不可掉落;

Handling after soldering after welding: Pay attention to the treatment of printed wiring board after welding.

Do not apply the following mechanical stress:

- ① the capacitor body shall not tilt, fall to the ground or twist;
- ② Do not grasp the main body of the capacitor to carry the circuit board;
- ③ Do not let other objects collide with the capacitor. In addition, when the printed wiring boards are placed on top of each other, the printed wiring boards or other parts must not touch the capacitors.
- ③ Printed circuit boards with capacitors installed shall not fall off;

10.1.10 电容器的废弃处理

废弃电容器时，请交给专业的工业废弃物处理厂进行处理。

此外，为了防止电容器爆炸，请在电容器上开孔或者充分碾碎之后焚烧。

Disposal of capacitors. When the capacitor is discarded, please hand it over to a professional industrial waste treatment plant for treatment. In addition, in order to prevent the capacitor from exploding, please open a hole in the capacitor or burn it after being fully crushed.

10.2. 关于AEC-Q200

我公司可以按照要求提供铝电解电容器的基于AEC-Q200标准的试验结果。

电子零部件制造商无法单纯的判断「AEC-Q200认定」。因此我司会针对对象产品，做出「基于」、「符合」、「可使用」等说法的判断。

详情请另外咨询。

We can provide the test results of aluminum electrolytic capacitors based on AEC-Q200 standard as required. Electronic component manufacturers cannot simply judge "AEC-Q200 certification". Therefore, We will make judgments on the statements of "based on", "conforming" and "usable" for the target products.

Please consult separately for details.

名称	Name	规格书 Specification		
版本	Version	03	页数 Page	18
标准指南		Standard Manual		

10.3 环境有害物质的对应Response to the Substances of Concern
 我司铝电解电容产品符合RoHs指令、REACH法规 以及无卤 。
 Our aluminum electrolytic capacitors comply with RoHs REACH and HF .

名称	Name	规格书 Specification		
版本	Version	03	页数 Page	19
标准指南 Standard Manual				