



microSD2.0 Specification

NOTE: INFORMATION IN THIS PRODUCT SPECIFICATION IS SUBJECT TO CHANGE AT ANYTIME WITHOUT NOTICE, ALL PRODUCT SPECIFICATIONS ARE PROVIDED FOR REFERENCE ONLY. TO ANY INTELLECTUAL, PROPERTY RIGHTS IN MK Founder CO., LTD. ALL INFORMATION IN THIS DOCUMENT IS PROVIDED.

Revision History:

Rev.	Date	Changes	Remark
1.0	2025/3/12	Basic spec and architecture	Preliminary



CONTENTS

1. Overview	1
1.1 Product Description	1
1.2 Features Summary	1
2. Pin Assignment	2
3. Product List	3
4. Current Consumption	4
5. Reliability and Durability	4
6. SD Card Registers	4
6.1 Card Identification Register (CID).....	4
6.2 Card Specific Data Register (CSD).....	5
7. Bus Operation Conditions	6
7.1 For 3.3V Signaling	6
7.1.1 Threshold Level for High Voltage Range	6
7.1.2 Peak Voltage and Leakage Current.....	6
7.1.3 Bus Signal Line Load	6
7.1.4 Bus Signal Levels.....	7
7.1.5 Bus Timing(Default).....	7
7.1.6 Bus Timing(High-Speed Mode).....	9
7.2 For 1.8V Signaling	10
7.2.1 Threshold Level for High Voltage Range	10
7.2.2 Peak Voltage and Leakage Current.....	10
7.2.3 Bus Timing Specification in SDR12, SDR25, SDR50 and SDR104 Modes .	10
7.2.3.1 Clock Timing	10
7.2.3.2 Card Input Timing	11
7.2.3.3 Card Output Timing	11
7.2.3.3.1 Output Timing of Fixed Data Window (SDR12, SDR25 and SDR50)	11
7.2.3.3.2 Output Timing of Variable Window (SDR104).....	12
8. Physical Dimension	12



1. Overview

1.1 Product Description

The microSD2.0 Cards are fully compatible with Physical Layer Specification, Version 2.0 (this specification is available from the SDA).

*Based on internal testing; performance may vary depending upon host device.

1 megabyte (MB) =1,000,000bytes.

1.2 Features Summary

-Capacity: 256MB

-Endurance: 100K(Typ)

-Complies to SD specifications version 1.0

-Voltage operating: 2.7~3.6V.

-Targeted for portable and stationary applications

-Greater Performance Choices

-Bus Speed Mode:

DS-Default Speed mode: 3.3V signaling, frequency up to 25MHz, up to 12.5MB/sec

HS-High Speed mode: 3.3V signaling, frequency up to 50MHz, up to 25MB/sec

-Switch function command supports Bus Speed Mode, Command System, Drive Strength, and future functions.

-Password protection (CMD42-LOCK_UNLOCK)

-Sophisticated system for error recovery including a powerful ECC

-Global Wear Leveling

-Power management for low power operation

2. Pin Assignment

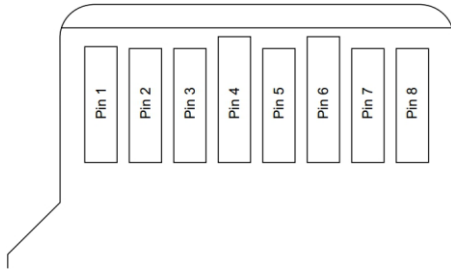

Pin No.	SD Mode			SPI Mode		
	Name	Type	Description	Name	Type	Description
1	Dat2	I/O/PP	Data Line [Bit 2]	RSV		Reserved
2	CD/DAT3	I/O/PP	Card Detect / Data Line [Bit 3]	CS	I	Chip Select
3	CMD	PP	Command/Response	DI	I	Data In
4	VDD	S	Supply voltage	VDD	S	Supply voltage
5	CLK	I	Clock	SCLK	I	Clock
6	VSS	S	Supply voltage ground	VSS	S	Supply voltage ground
7	DAT0	I/O/PP	Data Line [Bit 0]	DO	O/PP	Data Out
8	DAT1	I/O/PP	Data Line [Bit 1]	RSV		Reserved

S: power supply; I: input; O: output; PP: I/O using push-pull drivers

Table 1: Pin Assignment



3. Product List

Part Number	Capacity	Actual Size	Sequential Read MB/S	Sequential Write MB/S	Flash Type
MKUS256M-ITM1	256MB	238MB	17	10	SLC

Table 2: Product List

Note1: *Test Tool & Environment

1. Software: H2 test(Full Size)
2. Card Reader : Transcend TS-RDP5K (GL834)
3. Win7 OS



4. Current Consumption

Standby current: 80uA (Average value)

Operating current: 30mA (Average value)

*Test condition: Realtek5308 card reader (Voltage 3.3V), Fluke289C multi-meter.

5. Reliability and Durability

Temperature	Operation:-40°C/+85°C Storage:-40°C/+85°C
Moisture and corrosion	Operation: 25°C/95% rel. humidity Storage: 40°C/93% rel. hum./500h Salt Water Spray: 3% NaCl/35C; 24h acc. MIL STD Method 1009
Durability	10,000 insertion/removal cycles;
Bending	10[N] Center 200[mm/minute] 60[sec]
Torque	0.10Nm, +/-2.5 deg.max.
Drop test	1.5m free fall
Electrostatic Discharge (ESD)	IEC 61000-4-2 contact discharge: +/- 2[kV] and +/- 4[kV] 150[pF],330[Ohm] air discharge: up to +/- 15[kV] 150[pF], 330[Ohm]

Table 3: Reliability and Durability

6. SD Card Registers

6.1 Card Identification Register (CID)

The Card Identification (CID) register is 128 bit wide. It contains the card identification information used during the card identification phase. Every individual flash card shall have a unique identification number.

The structure of the CID register is defined in the following table.

CID Bit	Width	Name	Field
[127:120]	8	Manufacture ID	MID
[119:104]	16	OEM/Application ID	OID
[103:64]	40	Product Name	PNM
[63:56]	8	Product Revision	PRV
[55:24]	32	Product Serial Number	PSN
[23:20]	4	Reserved	---
[19:8]	12	Manufacturing Date	MDT
[7:1]	7	CRC7 check sum	CRC
[0]	1	Not used,always"1	---

Table 4: SD Card CID Table

- All contents in the CID table are programmable; Manufacturers can update the CID data through utility.
- Manufacturers should license MID and OID field form the SD Card Association(SDA)



6.2 Card Specific Data Register (CSD)

The Card-Specific Data register provides information regarding access to the card contents. The CSD defines the data format, error correction type, maximum data access time, whether the DSR register can be used, etc. The programmable part of the register (entries marked by W or E, see below) can be changed by CMD27. The CSD Table Version 2.0(as shown below) is applied to SDHC and SDXC Cards. Note that bits [15:0] are programmable by the host side. Refer to the SD specification for detailed information

CSD Bit	Width	Name	Field	Value	Note
[127:126]	2	CSD structure	CSD_STRUCTURE	00b	V1.0(<2G B Card)
[125:120]	6	Reserved	---	---	---
[119:112]	8	Data read access-time 1	(TAAC)	0E h	
[111:104]	8	Data read access-time2 in CLK cycles(NSA*100)	(NSAC)	00 h	
[103:96]	8	Max data transfer rate	(TRAN_SPEED)	32 h 5A h 0B h 2B h	
[95:84]	12	Card command classes	CCC	5B5 h	
[83:80]	4	Max. read data block length	(READ_BLK_LEN)	9 h	512 Byte
[79]	1	Partial block read allowed	(READ_BLK_PARTIAL)	0	
[78]	1	Write block misalignment	(WRITE_BLK_MISALIGN)	0	
[77]	1	Read block misalignment	(READ_BLK_MISALIGN)	0	
[76]	1	DSR implemented	DSR_IMP	x	
[75:70]	6	Reserve	---	---	
[69:48]	22	Device size	C_SIZE	xxxxxxh	
[47]	1	Reserved	---	0	
[46]	1	Erase single block enable	(ERASE_BLK_EN)	1	
[45:39]	7	Erase sector size	(SECTOR_SIZE)	7F h	
[38:32]	7	Write protect group size	C_SIZE	0 b	
[31]	1	Write protect group enable	---	0	
[30:29]	2	Reserved	(ERASE_BLK_EN)	0 b	
[28:26]	3	Write speed factor	(SECTOR_SIZE)	010 b	
[25:22]	4	Max. write data block length	(WP_GRP_SIZE)	9 h	
[21]	1	Partial block write allowed	(WP_GRP_ENABLE)	0	
[20:16]	5	Reserved	---	---	
[15]	1	File format group	(FILE_FORMAT_GRP)	0	
[14]	1	Copy flag	COPY	x	
[13]	1	Permanent write protection	PERM_WRITE_PROTECT	x	
[12]	1	Temporary write protection	TMP_WRITE_PROTECT	x	
[11:10]	2	File format	(FILE_FORMAT)	00 b	
[9:8]	2	Reserved	---	00 b	
[7:1]	7	CRC	CRC	---	
[0]	1	Not used,always'1'	---	1	

Table 5: CSD (Version 2.0) Table



7. Bus Operation Conditions

7.1 For 3.3V Signaling

7.1.1 Threshold Level for High Voltage Range

Parameter	Symbol	Min	Max	Unit	Remark
Supply Voltage	V _{DD}	2.7	3.6	V	
Output High Voltage	V _{OH}	0.75* V _{DD}		V	I _{OH} =2mA V _{DD min}
Output Low Voltage	V _{OL}		0.125* V _{DD}	V	I _{OL} =2mA V _{DD min}
Input High Voltage	V _{IH}	0.625* V _{DD}	V _{SS} +0.3	V	
Input Low Voltage	V _{IL}	V _{SS} -0.3	0.25* V _{DD}	V	
Power Up Time			250	ms	From 0V to V _{DD min}

Table 6: Threshold Level for High Voltage

7.1.2 Peak Voltage and Leakage Current

Parameter	Symbol	Min	Max	Unit	Remark
Peak voltage on all lines		-0.3	V _{DD} +0.3	V	
All Inputs					
Input Leakage Current		-10	10	uA	
All Outputs					
Output Leakage Current		-10	10	uA	

Table 7: Peak Voltage and Leakage Current

7.1.3 Bus Signal Line Load

Parameter	Symbol	Min	Max	Unit	Remark
Pull-up resistance	R _{CMD} R _{DAT}	10	100	K Ω	To prevent bus floating
Total bus capacitance for each signal line	C _L		40	pF	1 card C _{HOST} +C _{BUS} shall not exceed 30pF
Card capacitance for each signal pin	C _{CARD}		10	pF	
Maximum signal inductance			16	nH	
Pull-up resistance inside card(pin1)	R _{DAT3}	10	90	K Ω	May be used for card detection
Capacity Connected to Power Line	C _C		5	uF	To prevent inrush current

Table 8: Bus Operating Conditions - Signal Line's Load

7.1.4 Bus Signal Levels

As the bus can be supplied with a variable supply voltage, all signal levels are related to the supply voltage.

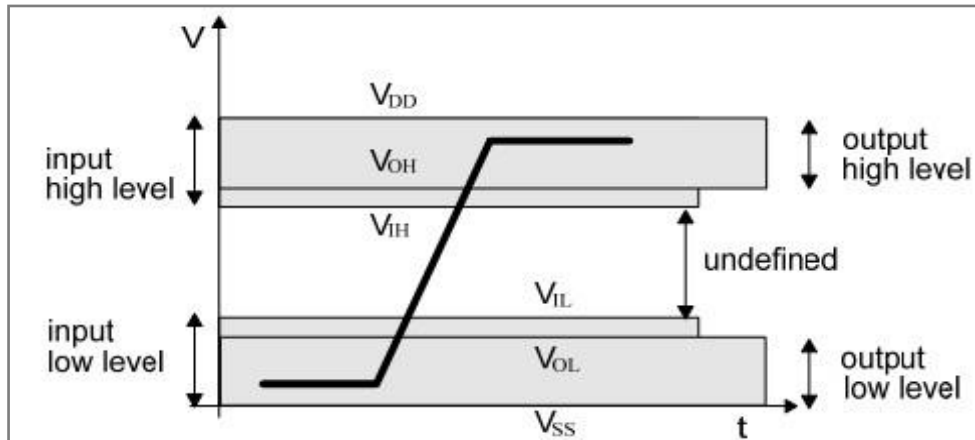

Figure 1: Bus Signal Levels

To meet the requirements of the JEDEC specification JESD8-1A and JESD8-7, the card input and output voltages shall be within the specified ranges shown in Table 6-2 for any VDD of the allowed voltage range:

7.1.5 Bus Timing(Default)

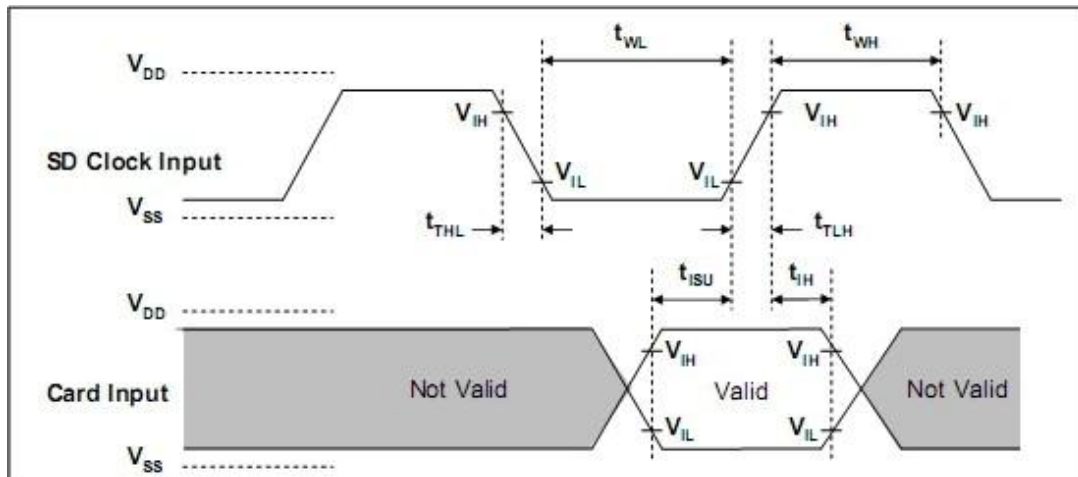

Figure 2: Card input Timing (Default Speed Card)

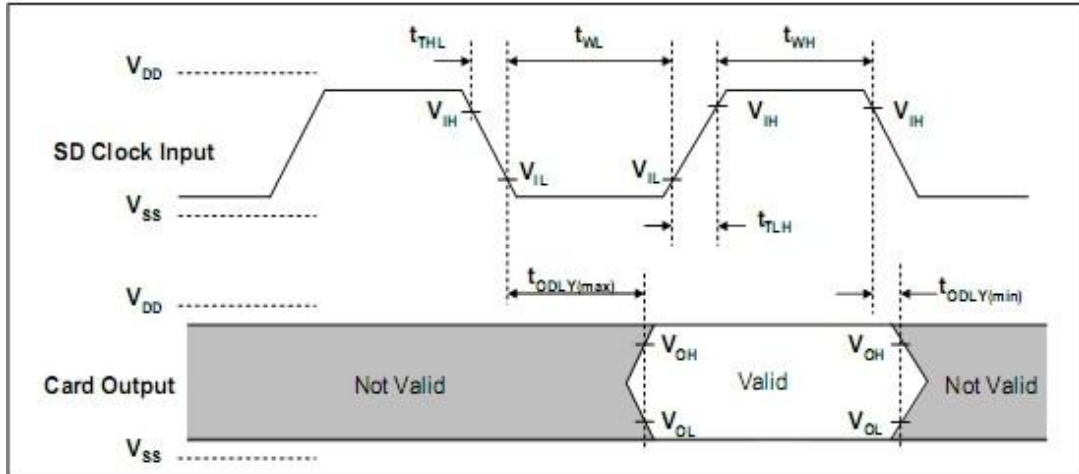

Figure 3: Card Output Timing (Default Speed Mode)

Parameter	Symbol	Min.	Max	Unit	Remark
Clock CLK (All values are referred to min (V_{IH}) and max (V_{IL}))					
Clock frequency data transfer Mode	fpp	0	25	MHz	$C_{CARD} \leq 10pF$ (1 card)
Clock frequency Identification Mode	f_{OD}	0 ⁽¹⁾ /100	400	KHz	$C_{CARD} \leq 10pF$ (1 card)
Clock low time	t_{WL}	10		ns	$C_{CARD} \leq 10pF$ (1 card)
Clock high time	t_{WH}	10		ns	$C_{CARD} \leq 10pF$ (1 card)
Clock rise time	t_{TLH}		10	ns	$C_{CARD} \leq 10pF$ (1 card)
Clock fall time	t_{THL}		10	ns	$C_{CARD} \leq 10pF$ (1 card)
Inputs CMD, DAT (referenced to CLK)					
Input set-up time	t_{ISU}	5		ns	$C_{CARD} \leq 10pF$ (1 card)
Input hold time	t_{IH}	5		ns	$C_{CARD} \leq 10pF$ (1 card)
Outputs CMD, DAT (referenced to CLK)					
Output Delay time during Data Transfer Mode	t_{ODLY}	0	14	ns	$C_L \leq 40pF$ (1 card)
Output Hold time	t_{OH}	0	50	ns	$C_L \leq 40pF$ (1 card)

(1) 0 Hz means to stop the clock. The given minimum frequency range is for cases where continuous clock is required (refer to Chapter 4.4-Clock Control)

Table 9: Bus Timing-Parameters Values (Default Speed)

7.1.6 Bus Timing (High-Speed Mode)

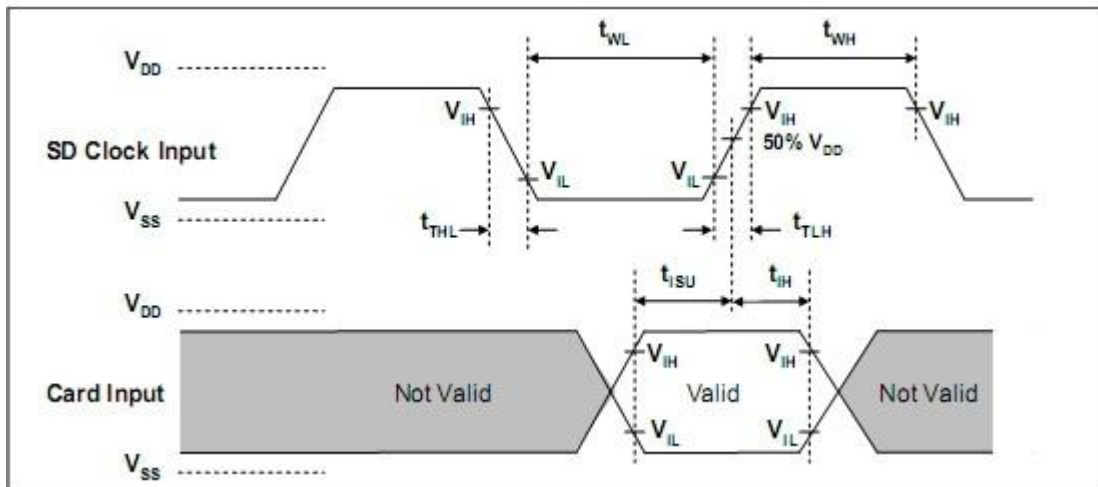

Figure 4: Card Input Timing(High Speed Card)

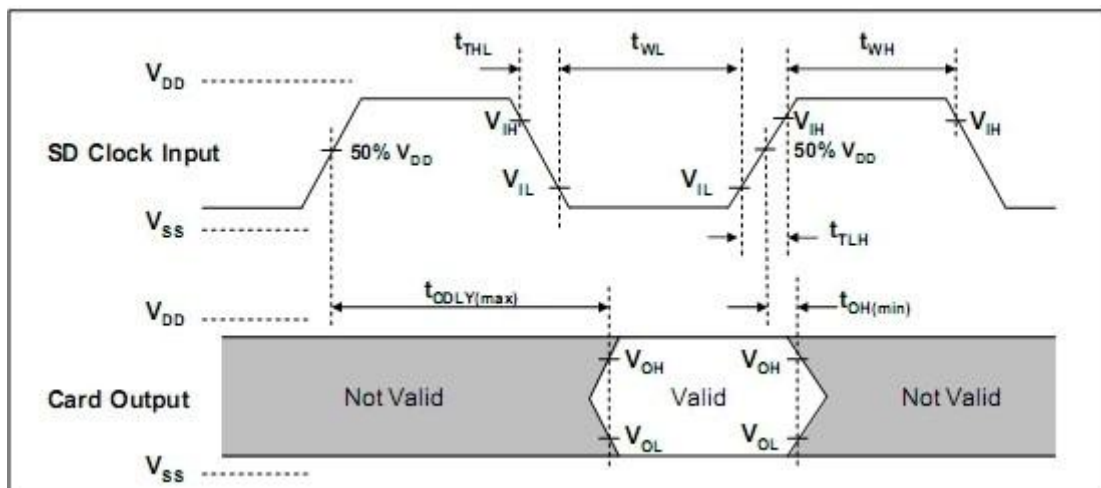

Figure 5: Card Output Timing(High Speed Mode)

Parameter	Symbol	Min.	Max	Unit	Remark
Clock CLK (All values are referred to min (V_{IH}) and max (V_{IL}))					
Clock frequency data transfer Mode	fpp	0	50	MHz	$C_{CARD} \leq 10pF$ (1 card)
Clock low time	t_{WL}	7		ns	$C_{CARD} \leq 10pF$ (1 card)
Clock high time	t_{WH}	7		ns	$C_{CARD} \leq 10pF$ (1 card)
Clock rise time	t_{TLH}		3	ns	$C_{CARD} \leq 10pF$ (1 card)
Clock fall time	t_{THL}		3	ns	$C_{CARD} \leq 10pF$ (1 card)
Inputs CMD, DAT (referenced to CLK)					
Input set-up time	t_{ISU}	6		ns	$C_{CARD} \leq 10pF$ (1 card)
Input hold time	t_{IH}	2		ns	$C_{CARD} \leq 10pF$ (1 card)
Outputs CMD, DAT (referenced to CLK)					



Output Delay time during Data Transfer Mode	t_{ODLY}		14	ns	$C_L \leq 40\text{pF}$ (1 card)
Output Hold time	t_{OH}	2.5		ns	$C_L \geq 15\text{pF}$ (1 card)
Total System capacitance for each line ^{1p}	C_L		40	pF	1 card

(1) In order to satisfy sever timing , host shall drive only one card.

Table 10: Bus Timing – Parameters Values (High Speed)

8. Physical Dimension

Type	Measurement
Length	15mm +/- 0.1mm(B)
Width	11mm +/- 0.1mm(A)
Thickness	1.0mm+/-0.1mm(C)
	0.7mm+/-0.1mm(C1)
Weight	0.33 gram Max

Physical Dimension Specifications (Unit in mm)



Mechanical form factor as follows: (Unit in mm)

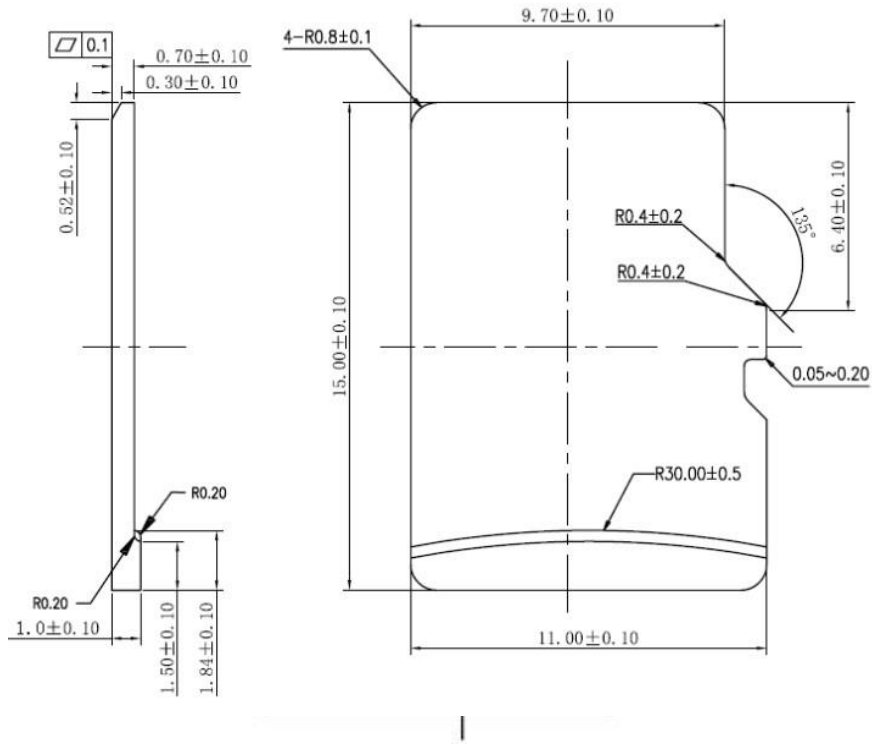

Figure 10: Dimension Drawing