

REV	ECN	DESCRIPTION	MDF' D	DATE
1.0	/	新发行	fan Z. J.	2023-10-18

No. of contacts	A	B	C	D	E	H2	H
Signal							
96	23.5	31.1	26.4	31.5	28.3		
120	29.5	37.1	32.4	37.5	34.3	3.5	4.0
144	35.5	43.1	38.4	43.5	40.3		
168	41.5	49.1	44.4	49.5	46.3		
96	23.5	31.1	26.4	31.5	28.3		
120	29.5	37.1	32.4	37.5	34.3	4.5	5.0
144	35.5	43.1	38.4	43.5	40.3		
168	41.5	49.1	44.4	49.5	46.3		
120	29.5	37.1	32.4	37.5	34.3	5.25	6.0
144	35.5	43.1	38.4	43.5	40.3		
168	41.5	49.1	44.4	49.5	46.3		
120	29.5	37.1	32.4	37.5	34.3	6.25	7.0
144	35.5	43.1	38.4	43.5	40.3		
168	41.5	49.1	44.4	49.5	46.3		
120	29.5	37.1	32.4	37.5	34.3	7.25	8.0
144	35.5	43.1	38.4	43.5	40.3		
168	41.5	49.1	44.4	49.5	46.3		

Unit: mm

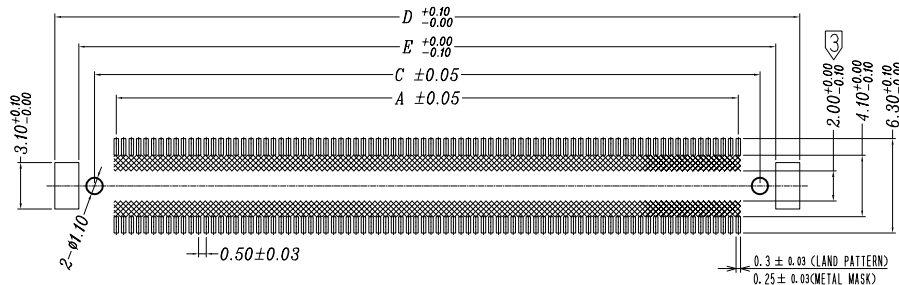
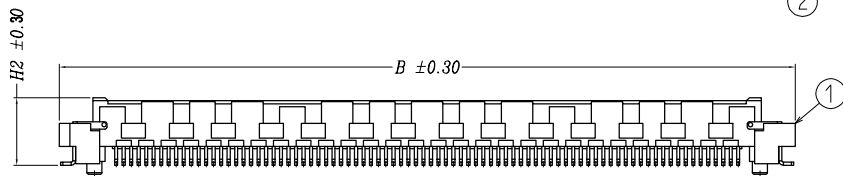
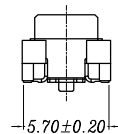
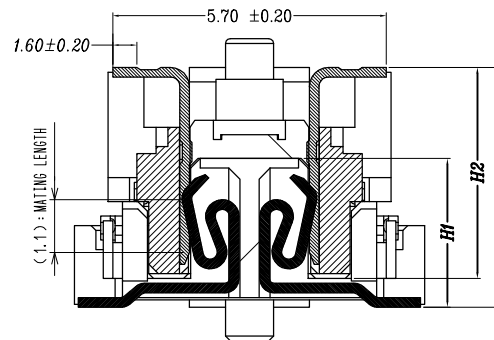
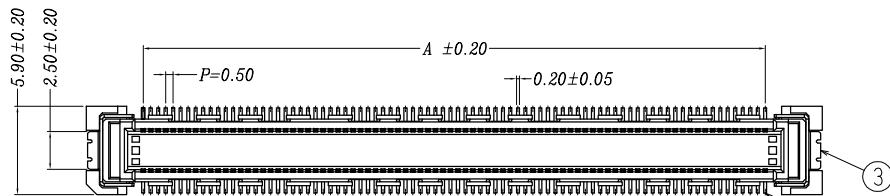

5001B-FX10535-\*\*-MR-00

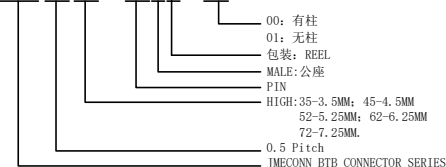

- NOTES
- SMT LEAD-COPLANARITY : 0.1 MAX.
  - THIS PRODUCT HAS NO POLARITY TO PATTERN FOR MOUNTING.
  - MAKE SURE WIDTH OF PATTERN IS WITHIN THAT OF LAND, OR LEAD MAY TOUCH PATTERN. (THIS APPLIES TO HATCHED AREA.)
  - EMBOSS CARRIER TAPE PACKAGE IS APPLIED ON THIS PRODUCT. PLEASE REFER TO THE SHEET 2/2 FOR THE DETAILS.
  - THE DIMENSIONS IN PARENTHESES ARE FOR REFERENCE.

.X ±0.20	.X° ±1.0°	<b>深圳市文章济美科技有限公司</b> Shenzhen wenzhangjimei Electronics Co., LTD	
.XX ±0.10	.XX° ±0.5°		
.XXX ±0.05	.XXX° ±0.2°	Part Name: FX10 0.5 PITCH BTB MALE	Approved:
SCALE 1:1	UNIT mm	Part No.: 5001B-FX10535-**-MR-00	Checked:
PAGE: 1/1	REV: 1.0	Title:	Material:
		Drawing No.: G8BTC0011	Mode NO.:
			Drawn: Fan Z. J.
			Date: 2023-10-18

NO	MATERIAL	FINISH	REMARKS
3	PHOSPHOR BRONZE	TIN-PLATING	
2	PHOSPHOR BRONZE	CONTACT AREA : GOLD 0.1µm min.	
		LEAD AREA : TIN-PLATING 1µm min.	
1	LCP	BEIGE	



REV	ECN	DESCRIPTION	MDF'D	DATE
1.0	/	新发行	fan Z. J.	2023-10-18

No of Contacts Signal	Dimension					Unit:mm
	A	B	C	D	E	
96	23.50	31.10	26.40	31.50	28.30	
120	29.50	37.10	32.40	37.50	34.30	
144	35.50	43.10	38.40	43.50	40.30	
168	41.50	49.10	44.40	49.50	46.30	

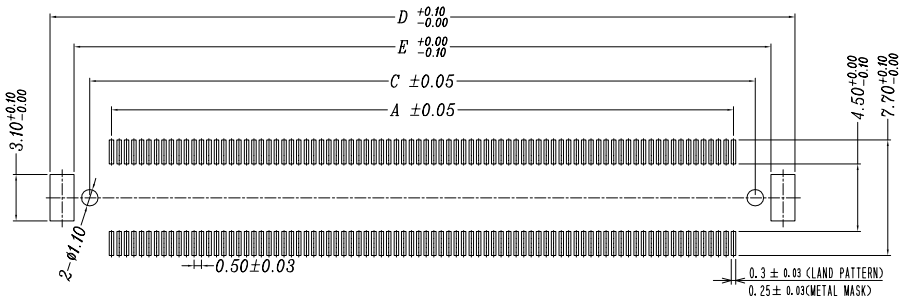
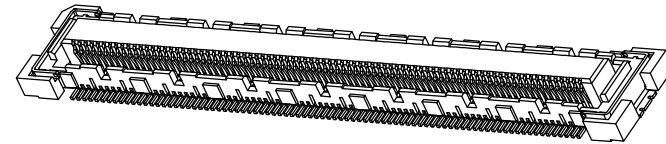
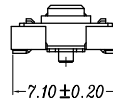
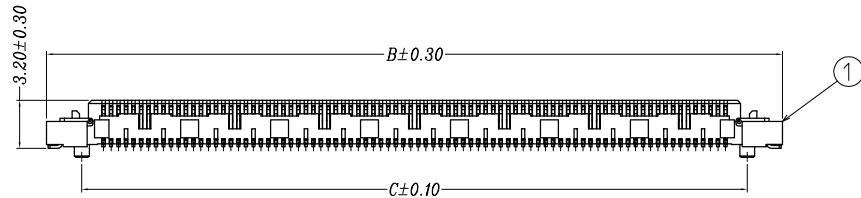
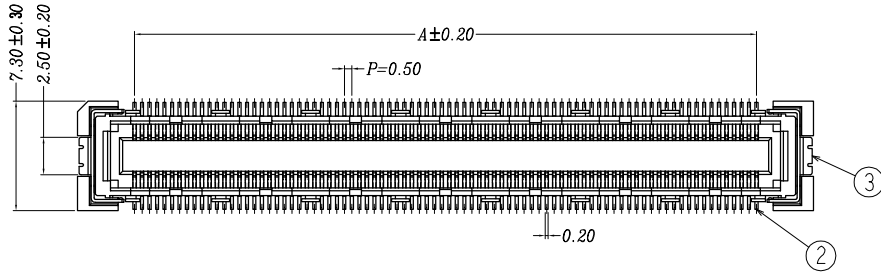

NOTES:

1. SMT LEAD-COPLANARITY: 0.1 MAX.
2. THIS PRODUCT HAS NO POLARITY TO MOUNT ON THE RECOMMENDED LAND PATTERN.

5001B-FX10532-\*\*-FR-00

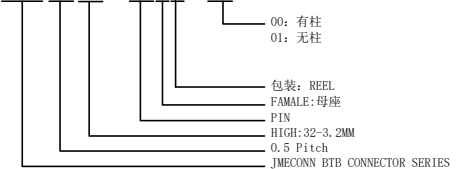

NO	MATERIAL	FINISH	REMARKS
3	PHOSPHOR BRONZE	TIN-PLATING	
2	PHOSPHOR BRONZE	CONTACT AREA	: GOLD 0.1 μm min.
		LEAD AREA	: TIN-PLATING 1 μm min.
1	LCP	BEIGE	
NO	MATERIAL	FINISH	REMARKS

.X ±0.20	.X° ±1.0°	<b>深圳市文章济美科技有限公司</b> Shenzhen wenzhangjimei Electronics Co., LTD	
.XX ±0.10	.XX° ±0.5°		
.XXX ±0.05	.XXX° ±0.2°	Part Name: FX10 0.5 PITCH BTB FEMALE	Approved:
SCALE 1:1 UNIT mm		Part No.: 5001B-FX10532-**-FR-00	Checked:
PAGE: 1/1	REV: 1.0	Title:	Material:
		Drawing No.: G8BTC0012	Mode NO.:
			Drawn: Fan Z. J.
			Date: 2023-10-18

**1. SCOPE****1.1 CONTENTS**

This specification covers the performance, tests and quality requirements for the 15+ Gbps 0.5mm Pitch stacking connectors.

**2. APPLICABLE DOCUMENT**

The following JME CONN documents form a part of this specification the extent specified herein.

Unless otherwise specified, the latest edition of document applies. In the event of conflict between the requirements of this specification and the product drawings, the product drawing shall take precedence. In the event of conflict between the requirements this specification and the referenced documents, this specification shall take precedence.

**3. REQUIREMENTS****3.1 DESIGN AND CONSTRUCTION**

Product shall be of the design, construction and physical dimensions specified on the applicable product drawings.

**A. MATERIALS**

B. Housing: LCP High-temp thermoplastic, UL 94v-0, White

Contacts: phosphor bronze

Header:contact Area: Gold plating

lead Area: Tin plating

Receptacle contact area: Gold plating

Lead area: Flash plating

C. Ground plate: Phosphor bronze

tin plating

**3.2 RATINGS**

A. Voltage rating: 50VAC

B. Current rating : 0.5A Max.

C. Operating temperature: -25° C to +85° C (Including terminal temperature rise)

D. Operating humidity range: Relative humidity 93% Max.

E. Storage temperature range: 20±8° C

F. Storage humidity range: Relative humidity 60% Max.

**3.3 PERFORMANCE REQUIREMENT AND TEST DESCRIPTION**

The product shall be designed to meet the electrical, mechanical and environmental performance Requirements specified in Figure 1. All tests shall be performed at ambient environmental conditions.

	测试项目 TEST ITEM	规格 REQUIREMENT	测试方式/条件 PROCEDURE
1	外观检查 Examination of Product	符合图面外观, 无任何形状损坏; Meets requirements of product Drawing. No physical damage.	目视检查 Visual inspection.
电气特性 ELECTRICAL REQUIREMENT			
2	接触电阻 Contact Resistance	60mΩ 以下 60mΩ Max.	将样品成对连接, 开放电压20mV以下, 限电流100mA的状态下进行测试。 Mate the sample connectors, measure by dry circuit, 20mV Max., 100mA Max. (EIA-364-23)
3	绝缘阻抗 Insulation Resistance	100 MΩ min. Initial	未连接的样品, 提供相邻端子间或端子与地面间加 AC 500V 进行绝缘阻抗测试。 Impressed voltage 500V AC Test between adjacent Circuits of unmated connectors. (EIA-364-21)
4	耐电压 Dielectric withstanding voltage	目视外观无任何击穿损坏。 No breakdown. 电流泄漏: 1mA Max. Current leakage: 1 mA Max.	未连接的样品, 提供相邻端子间或端子与地面间加 AC 500V (有效值) 历时1分钟下测定耐电压。 Unmated the sample connectors, Apply 500V AC for 1minute test between adjacent circuit of unmated connector. (EIA-364-20)
机械特性 MECHANICAL REQUIREMENT			
5	接触保持力 Contact retention Force	0.01 Kgf/Pin 以上。 0.01 Kgf/Pin Min.	AC 500V 进行绝缘阻抗测试。 Impressed voltage 500V AC Test between adjacent Circuits of unmated connectors. (EIA-364-21)
6	插拔力 Mating and unmating force	9.8N Maximum. per pin 0.13 N Minimum. Per pin	将成品对连接器焊板连接, 以操作速度每分钟位移 25±3 mm进行插入力测试。 Mate the sample connectors shall be soldered on a board and inserted and separated at speed of 25±3mm/min. (EIA-364-13)

测试项目 TEST ITEM		规格 REQUIREMENT		测试方式/条件 PROCEDURE
<b>机械特性 MECHANICAL REQUIREMENT</b>				
7	耐插拔 Durability	外观 Appearance	目视外观上无任何损坏变形。 No damage.	将样品成对连接，以操作速度每分钟位移 $25\pm 3\text{mm}$ 进行50次插拔测试。 Mate the sample connectors should be mounted in the tester and fully mated and unmated the number of 50 cycles specified at the rate of $25\pm 3\text{mm}/\text{min}$ . (EIA-364-09)
		接触阻抗 Contact resistance	$60\text{m}\Omega$ 以下 $60\text{m}\Omega$ Max.	
8	耐振动 Vibration	外观 Appearance	目视外观上无任何损坏变形。 No damage.	通过DC电流1mA, 位移相对距离1.5mm, 振动周期 $10\sim 55\sim 10\text{Hz}$ 在1分钟内, 连续2小时, 方向X, Y, Z轴做测试。 Mate connectors and subject to the following vibration conditions for period of 2 hours in each of 3 mutually perpendicular axes passing DC 1 mA during the test. Amplitude: 1.5mm P-P Frequency: $10\sim 55\sim 10\text{Hz}$ in 1 minute.
		接触阻抗 Contact resistance	$60\text{m}\Omega$ 以下 $60\text{m}\Omega$ Max.	
		瞬间断电 Discontinuity	1 $\mu$ sec Max.	
9	耐冲击性 Shock (Mechanical)	外观 Appearance	目视外观上无任何损坏变形。 No damage.	将样品成对连接, 通过DC 1mA 测试条件, 连续测试3次。在X、Y、Z 3个轴6个垂直方向施予重力加速度 $490\text{m}/\text{s}^2$ (50G)冲击。 Mate the sample connectors shall and subject to the following shock condition. 3 time of shocks shall be applied for each 6 directions along 3 mutually perpendicular axes, passing DC 1 mA current during the test. ( Total of 18 shocks) peak value $490\text{m}/\text{s}^2$ (50G)
		接触阻抗 Contact resistance	$60\text{m}\Omega$ 以下 $60\text{m}\Omega$ Max.	
		瞬间断电 Discontinuity	1 $\mu$ sec Max.	
<b>环境特性及其它性能 (ENVIRONMENT PERFORMANCE AND OTHERS)</b>				
10	温升 Temperature Rising	负载额定电流下温度 $30^\circ\text{C}$ $30^\circ\text{C}$ Max. Under loaded rating current.		量测通过成对连接样品最大容许电流时, 样品接触点处温升。 Mate the sample connectors and measure the temperature rise of contact when the maximum AC rated current is passed. ( EIA-364-70 METHOD 2 )

测试项目 TEST ITEM		规格 REQUIREMENT		测试方式/条件 PROCEDURE
环境特性及其它性能 (ENVIRONMENT PERFORMANCE AND OTHERS)				
11	耐热性 Heat resistance	外观 Appearance	目视外观上无任何损坏变形。 No damage.	将样品成对连接置于环境温度 $85\pm 2^{\circ}\text{C}$ ，测试时间96小时，再置于室温下1~2小时。 Mate the sample connectors shall expose to $85\pm 2^{\circ}\text{C}$ for 96 hours. Upon completion of the exposure period, the test specimens shall be conditioned at ambient room condition for 1 to 2 hours, after which the specified measurements shall performed.
		接触阻抗 Contact resistance	60m $\Omega$ 以下 60m $\Omega$ Max.	
12	耐寒性 Cold resistance	外观 Appearance	目视外观上无任何损坏变形。 No damage.	将样品成对连接置于环境温度 $-55\pm 2^{\circ}\text{C}$ ，测试时间96小时，再置于室温下1~2小时。 Mate the sample connectors shall expose to $-55\pm 2^{\circ}\text{C}$ for 96 hours. Upon completion of the exposure period, the test specimens shall be conditioned at ambient room condition for 1 to 2 hours, after which the specified measurements shall performed.
		接触阻抗 Contact resistance	60m $\Omega$ 以下 60m $\Omega$ Max.	
13	耐湿性 Humidity	外观 Appearance	目视外观上无任何损坏变形。 No damage.	将样品成对连接置于环境温度 $-55\pm 2^{\circ}\text{C}$ ，相对湿度90~95，测试时间96小时，再置于室温下1~2小时。 Mate the sample connectors shall expose to $-55\pm 2^{\circ}\text{C}$ relative humidity 90~95% for 96 hours. Upon completion of the exposure period, the test specimens shall be conditioned at ambient room condition for 1 to 2 hours. after which the specified measurements shall performed.
		接触阻抗 Contact resistance	60m $\Omega$ 以下 60m $\Omega$ Max.	
		耐电压 Dielectric strength	需能符合电压试 No breakdown	
		绝缘阻抗 Insulation resistance	60 M $\Omega$ 以上 60 M $\Omega$ Min.	

测试项目 TEST ITEM	规格 REQUIREMENT	测试方式/条件 PROCEDURE
环境特性及其它性能 (ENVIRONMENT PERFORMANCE AND OTHERS)		
14 温度循环 Contact resistance	外观 Appearance	将样品成对连接, 承受5 cycles冷热冲击后, 置至室温下1~2小时, 1 cycle time如下: -55±3°, 30分钟 +88±3°, 30分钟 A connector shall and subject to the following condition for 5 cycles. Upon completion of the exposure period, the test speciments shall be conditioned at ambient room condition for 1 to 2 hours. after which the specified measurements shall be performed. 1 cycle time: -55±3°, 30 minutes +88±3°, 30 minutes (Transit time shall be with in 3 minutes) (EIA-364-31, Test condition A)
	接触阻抗 Contact resistance	
15 盐水喷雾 Salt spray	外观 Appearance	将样品成对连接置, 使用5±1%浓度盐水, 测试温度35±2°, 测试时间16小时后, 室温下使用清水冲洗再干燥。 Mate the sample connectors shall expose to the following salt mist conditions. Upon completion of the exposure perion, Salt deposits shall be removed by a gentle wash or dip in running water, after which the specified Nacl solution concentration:5±1% Spray time: 16 hours ambient Temperature: 35±2° C (EIA-364-26, Test condition B)
16 焊锡性 Solder ability	润湿性 Solder wetting	润湿面积95%以上, 并不得有漏焊针孔现象。 95% of immersed area must show no voids, pin holes. 锡温250±5° C, 将导电端子浸入锡炉液面至Housing距离锡面0.1mm位置, 焊锡时间3±0.5秒。 Tip of solder tails and fitting mails into the molten solder (held at 250±5° C) up to 0.1mm form the Housing for 3±0.5 sec onds. (EIA-364-52 )

测试项目 TEST ITEM		规格 REQUIREMENT		测试方式/条件 PROCEDURE
<b>环境特性及其它性能 (ENVIRONMENT PERFORMANCE AND OTHERS)</b>				
17	焊锡耐热性 Resistance to reflow soldering Heat	外观 Appearance	目视外观上无任何损坏变形。 No damage.	使用红外线回流焊时请参考第4点 When reflowing... Refer to paragra 4. 使用烙铁手焊时须符合下述焊锡条件。 Soldering iron method 0.2mm from terminal tip and fitting nail tip. Soldering time: 5 seconds Max. soldering temperature: 370~400° C

**4. INFRARED REFLOW CONDITION (Lead free)**

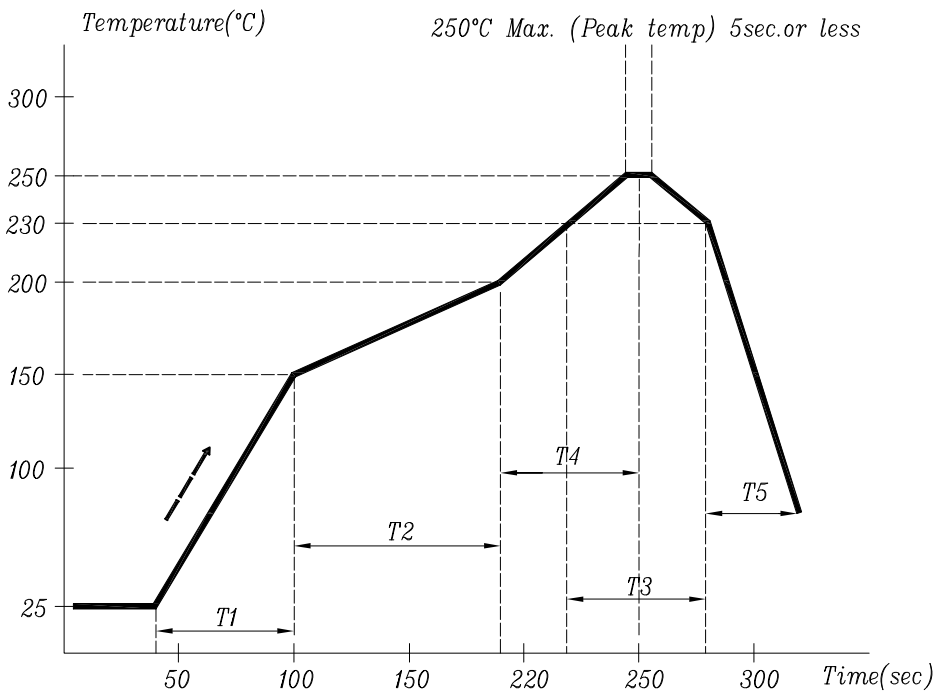

T1	Temperature Ramp Up Rate	21~5°/Sec
T2	Preheat: 150Y~200'	60~90 Sec
T3	Time over 230t	30~50 Sec
T4	Preheat: 200P~250C	30 Sec
T5	Remp down rate during cooling	如~
	Peak temperature	250t Max.

**Note:**

Please check the reflow soldering condition by your own devices beforehand. Because the condition changes by the soldering devices, P.C. Board and so on.

## 5. PRODUCT QUALIFICATION AND RELIABILITY TEST SEQUENCE

Test or Examination	1st Group											
	A	B	C	D	E	F	G	H	I	J	K	L
Appearance (外观)	1;7	1;3	1;6	1;6	1;6	1;3	1;6	1;6	1;5	1;5	1;3	1;3
Contact Resistance(接触电阻)			2;5	2;5	2;5			2;5	2;4	2;4		
Dielectric Withstanding Voltage(耐电压)	3;6											
Insulation Resistance(绝缘阻抗)	2;5											
Insertion Force(插入力)		2										
Contact Retention Force(接触保持力)			3;4									
Vibration (耐振动)				3;4								
Shock Mechanical(耐冲击性)					3;4							
Temperature Rising(温升)						2						
Heat Resistance(抗热性)							3;4					
Cold Resistance(耐寒性)								3;4				
Humidity (耐湿性)												
Temperature Cycling(温度循环)									3			
Salt Spray (盐水喷雾)										3		
Solder ability(可焊性)											2	
Resistance to Soldering Heat(焊锡耐热性)												2

Figure 2

Note:

- (a) Numbers indicate sequence in which tests are performed.
- (b) Discontinuities shall not take place in this test group, during test.

# 东莞市文章济美电子有限公司

## FX系列BTB高频仿真报告

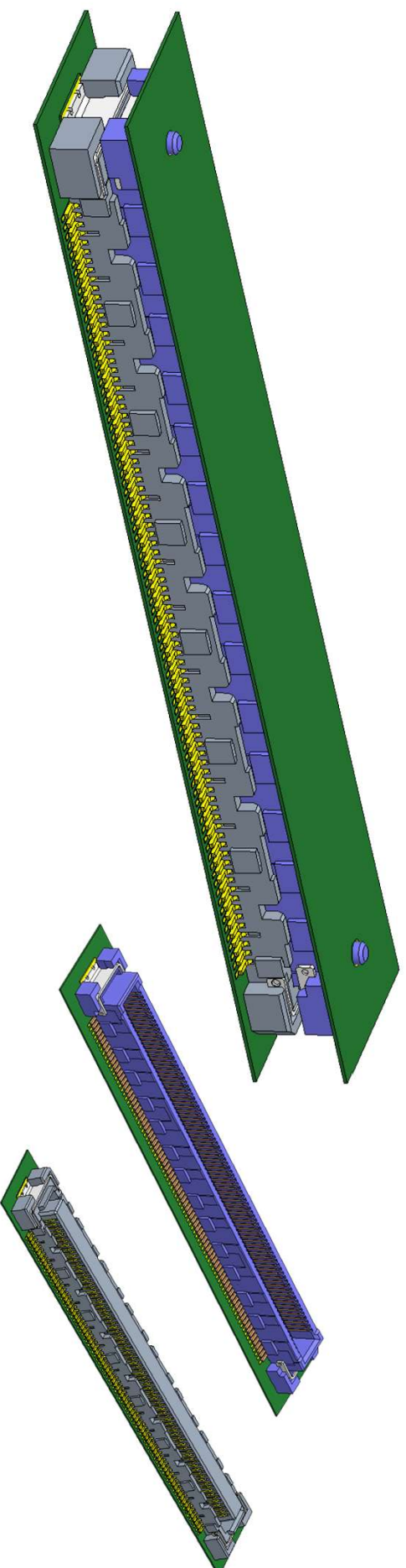

# PIN定义设置

## ● Pin assignment

To match 100 ohm differential impedance and to reduce crosstalk, a staggered GSSGSG pin assignment is recommended.  
(G=ground and S=signal)

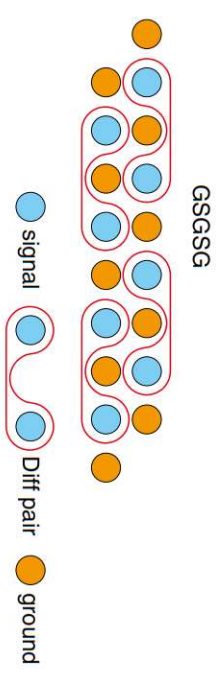

# 材料定义设置

Electrical properties	Standard	Value
Volume Resistivity	IEC 60093	9E+15
Dielectric Strength 1.0mm	IEC 60243	44
Dielectric Strength 3.0mm	IEC 60243	24
Dielectric Constant 1KHz	IEC 60250	4.3
Dielectric Constant 1MHz	IEC 60250	3.8
Dissipation Factor 1KHz	IEC 60250	0.02
Dissipation Factor 1MHz	IEC 60250	0.03

## 介质材料参数定义

塑胶介质材料定义LCP E1301, 参数参照上表  
金属材料定义为铜, 镀层为Ni+Au  
PCB介质定义为Rogers TMM 4

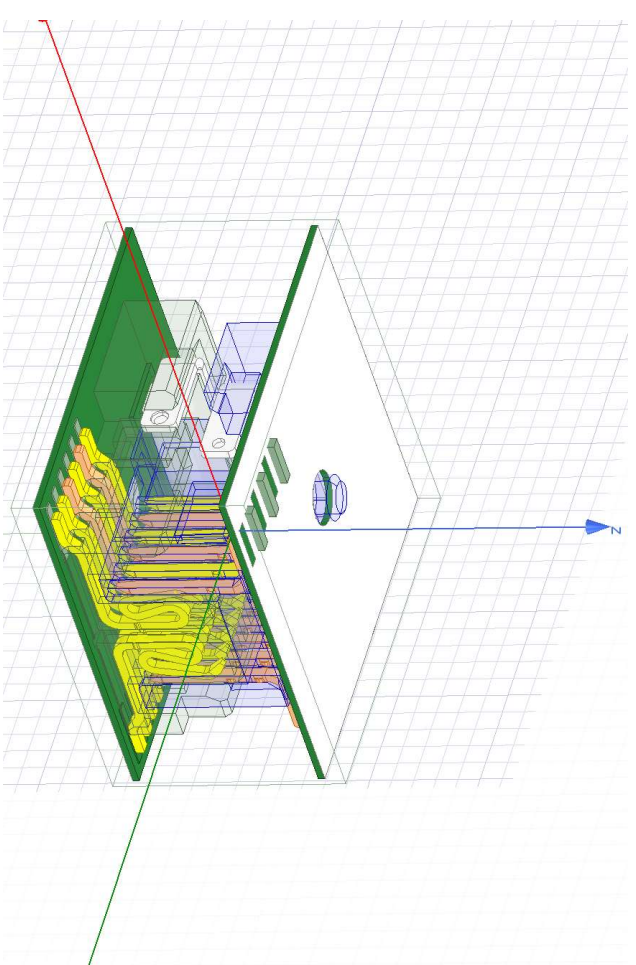

# 介质磁场分布云图

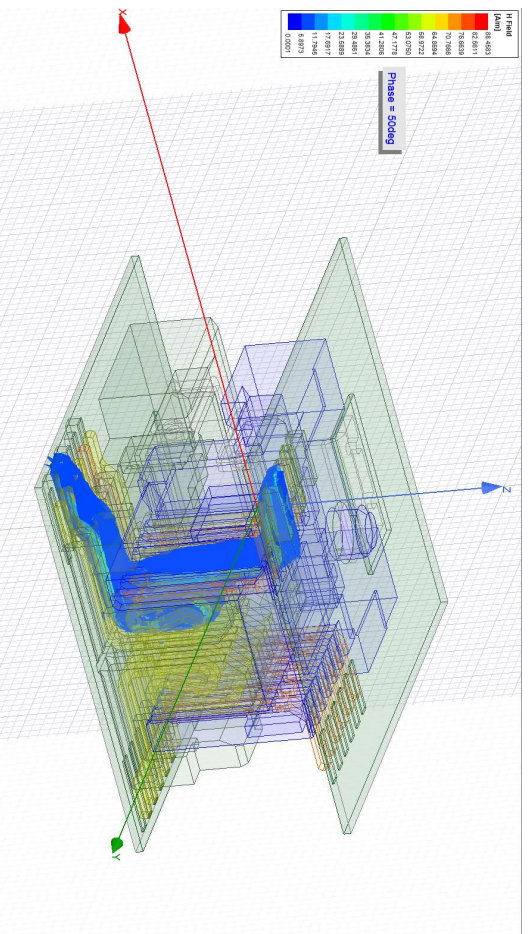

# 导体电场分布云图

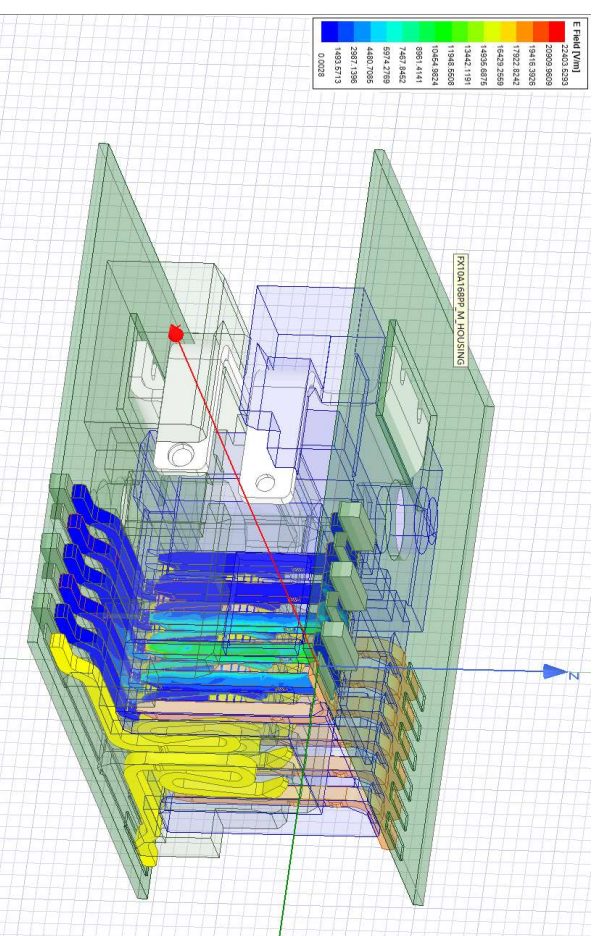

# 特性阻抗

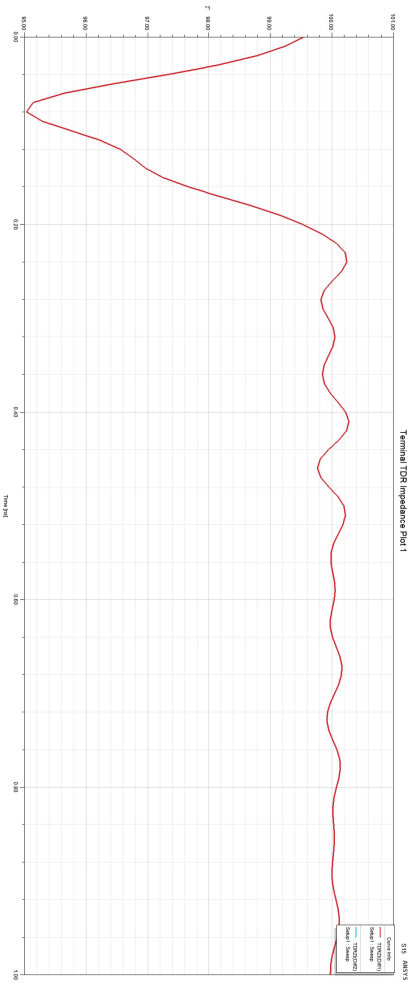

PLUG端 → REC端

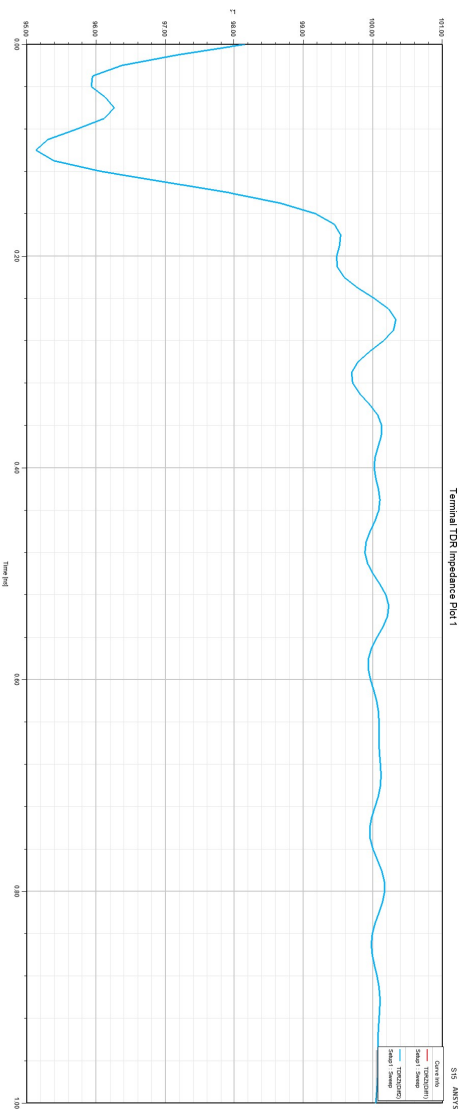

REC端 → PLUG端



# 插入损耗 (Insertion loss)

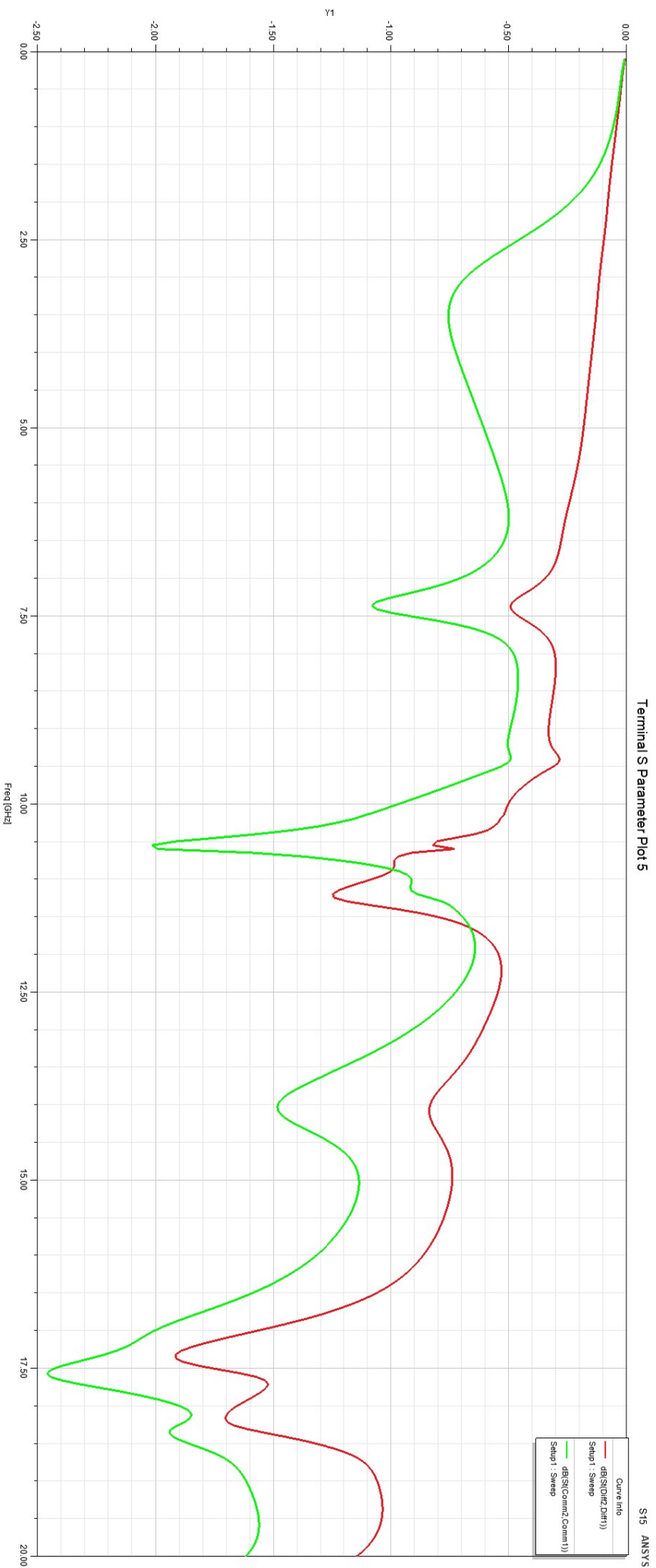

# 回波损耗 (Return loss)



# 近端串绕 (Near-end crosstalk (NEXT))

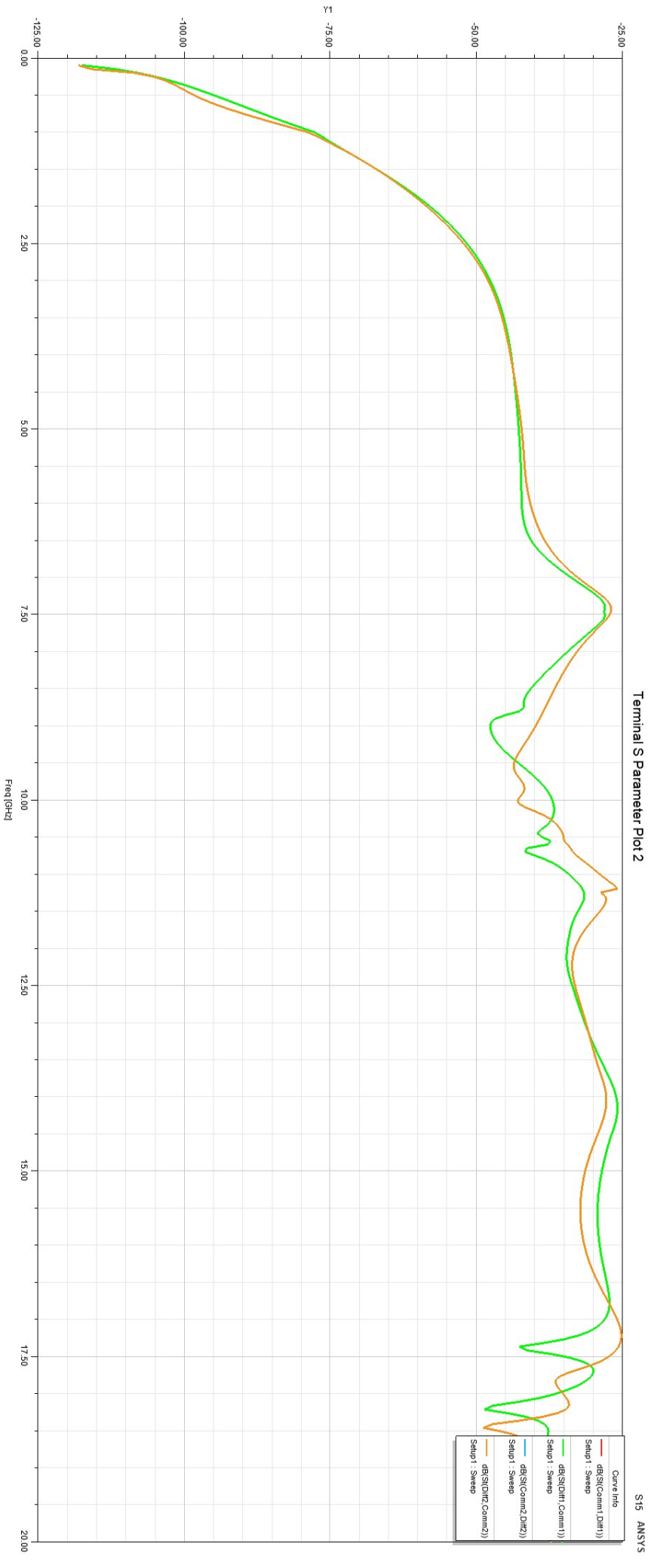

# 远端串绕 (Far-end crosstalk (FEXT))

