

1 FEATURES

- True RS-232 Operation from $V_{CC} = +3.0V$ to $+5.5V$
- 1 μA Supply Current Achieved with AutoShutdown
- Guaranteed 250kbps Data Rate
- Two Drivers and Two Receivers
- Automatic power-down feature automatically disables drivers for power savings
- Software control option for shutdown
- Meets or exceeds the requirements of TIA/EIA-232-F and ITU V.28 standards
- Enhanced ESD specifications:
 ±15kV Human Body Model
 ±15kV IEC61000-4-2 Air Discharge
 ±8kV IEC61000-4-2 Contact Discharge

2 APPLICATIONS

- Notebook, Subnotebook, and Palmtop Computers
- Cellular Phones
- Battery-Powered Equipment
- Handheld Equipment
- Peripherals
- Printers

3 DESCRIPTION

The GM3223E is 3V/5.5V powered communications interfaces with automatic shutdown/wake up features, high data rate capabilities, and enhanced electrostatic discharge (ESD) protection. Transmitter output and receiver input are protected to ±15kV using IEC 1000-4-2 Air Gap Discharge, to ±8kV using IEC 1000-4-2 Contact Discharge, and to ±15kV using the Human Body Model. The GM3223E device consists of two line drivers, two line receivers with dedicated enable pin. It saves power without changes to the existing BIOS or operating system by entering low-power shutdown mode when the RS-232 cable is disconnected, or when the transmitters of the connected peripherals are off. The transceivers have a proprietary low-dropout transmitter output stage, delivering true RS-232 performance from a +3.0V to +5.5V supply with a dual charge pump. The charge pump requires only four small 0.1 μF capacitors for operation from a +3.3V supply. Each device is guaranteed to run at data rates of 250kbps while maintaining RS-232 output levels.

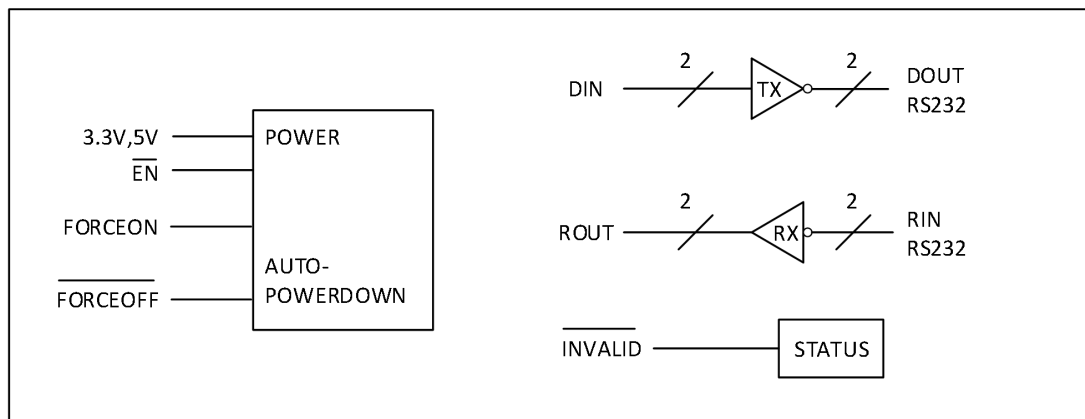

Simplified Circuit Diagram

4 Pin Configuration and Functions

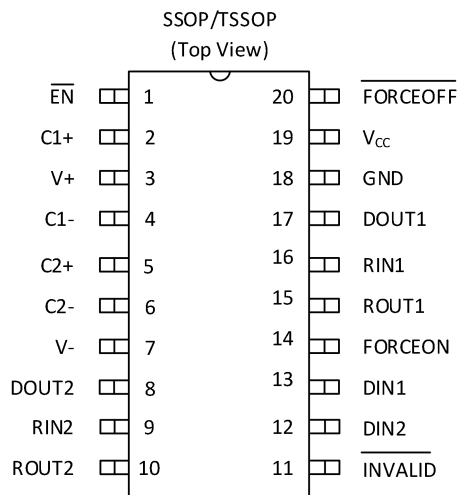

Pin		Type	Description
Name	No.		
C1+	2	-	Positive terminal of the voltage-doubler charge-pump capacitor
C2+	5	-	Positive terminal of the voltage-doubler charge-pump capacitor
C1-	4	-	Negative terminal of the voltage-doubler charge-pump capacitor
C2-	6	-	Negative terminal of the voltage-doubler charge-pump capacitor
DIN1	13	I	TTL/CMOS driver input
DIN2	12	I	TTL/CMOS driver input
DOUT1	17	O	RS-232 driver output
DOUT2	8	O	RS-232 driver output
EN	1	I	Low input enables receiver ROUT output. High input sets ROUT to high impedance.
FORCEOFF	20	I	Auto Powerdown Control input (Refer to Truth Table)
FORCEON	14	I	Auto Powerdown Control input (Refer to Truth Table)
GND	18	-	Ground
INVALID	11	O	Invalid output pin. Output low when all RIN inputs are unpowered.
RIN1	16	I	RS-232 receiver input
RIN2	9	I	RS-232 receiver input
ROUT1	15	O	TTL/CMOS Receiver Output
ROUT2	10	O	TTL/CMOS Receiver Output
V _{CC}	19	-	3V to 5.5V supply voltage
V+	3	O	5.5V supply generated by the charge pump
V-	7	O	-5.5V supply generated by the charge pump

5 Specifications

5.1 Absolute Maximum Ratings⁽¹⁾

over operating free-air temperature range (unless otherwise noted)⁽¹⁾

Parameter	Description	MIN	MAX	UNIT	
V _{cc}	Supply Voltage range ⁽²⁾	-0.3	6	V	
V ₊	Positive output supply voltage range ⁽²⁾	-0.3	7	V	
V ₋	Negative output supply voltage range ⁽²⁾	0.3	-7	V	
V ₊ - V ₋	Output supply voltage difference ⁽²⁾		13	V	
V _I	Input voltage range	Driver (FORCEOFF, FORCEON)	-0.3	6	V
		Receiver	-25	25	
V _O	Output voltage range	Driver	-13.2	13.2	V
		Receiver (INVALID)	-0.3	V _{cc} +0.3	
T _J	Junction Temperature		150	°C	
T _{stg}	Storage temperature range	-65	150	°C	

(1) Stresses beyond those listed under Absolute Maximum Ratings may cause permanent damage to the device. These are stress ratings only, and functional operation of the device at these or any other conditions beyond those indicated under Recommended Operating Conditions is not implied. Exposure to absolute-maximum-rated conditions for extended periods may affect device reliability.

(2) All voltages are with respect to network GND.

5.2 ESD Ratings

Parameter			Limit	Unit	
V _(ESD)	Electrostatic discharge	HBM (Human Body Model), per ANSI/ESDA/JEDEC JS-001 ⁽¹⁾	DOUT, RIN	±3000	V
			Other Pins	±15000	
		Charged-device model (CDM), per JEDEC specification JESD22-C101 ⁽²⁾		±1500	

5.3 Recommended Operating Conditions

See [Figure 7](#)⁽¹⁾

Parameter	Description			MIN	NOM	MAX	UNIT	
V _{cc}	Supply Voltage range	V _{cc} =3.3V		3	3.3	3.6	V	
		V _{cc} =5V		4.5	5	5.5		
V _{IH}	Driver and control high-level input voltage	DIN, FORCEOFF, FORCEON	V _{cc} =3.3V	2			V	
			V _{cc} =5V	2.4		5.5		
V _{IL}	Driver and control low-level input voltage	DIN, FORCEON, EN, FORCEOFF				0.8	V	
V _I	Driver and control input voltage	DIN, FORCEON, EN, FORCEOFF		0		5.5	V	
V _I	Receiver input voltage				-25		25	V
T _A	Operating free-air temperature				-40		85	°C

(1) Test conditions are C1–C4 = 0.1μF at V_{cc} = 3.3 V ± 0.3 V; C1 = 0.047μF, C2–C4 = 0.33μF at V_{cc} = 5 V ± 0.5 V.

5.4 Thermal Information

PARAMETER		SSOP	TSSOP	UNIT
R _{ΘJA}	Junction-to-ambient thermal resistance	91.0	94.1	°C/W
R _{ΘJC(top)}	Junction-to-case (top) thermal resistance	46.2	35.2	°C/W
R _{ΘJB}	Junction-to-board thermal resistance	46.1	45.5	°C/W
ψ _{JT}	Junction-to-top characterization parameter	12.3	3.1	°C/W
ψ _{JB}	Junction-to-board characterization parameter	45.6	45.1	°C/W

5.5 Electrical Characteristics

over recommended ranges of supply voltage and operating free-air temperature (unless otherwise noted)⁽¹⁾
 (see [Figure 7](#))

Parameter		TEST CONDITIONS	MIN	TYP ⁽²⁾	MAX	UNIT
I _I	Input leakage current	FORCEON, EN, FORCEOFF		±0.01	±1	μA
I _{CC}	Supply current (T _A = 25°C)	Auto-powerdown disabled	No load, FORCEOFF and FORCEON at V _{CC}	0.3	1	mA
		Powered off	No load, FORCEOFF at GND	1	10	μA
		Auto-powerdown enabled	No load, FORCEOFF at V _{CC} , FORCEON at GND, All R _{IN} are open or grounded, All D _{IN} are grounded	1	10	μA

(1) Test conditions are C1–C4 = 0.1μF at V_{CC} = 3.3 V ± 0.3 V; C1 = 0.047μF, C2–C4 = 0.33μF at V_{CC} = 5 V ± 0.5 V.

(2) All typical values are at V_{CC} = 3.3 V or V_{CC} = 5 V, and T_A = 25°C.

5.6 Driver Electrical Characteristics

over recommended ranges of supply voltage and operating free-air temperature (unless otherwise noted)⁽¹⁾
 (see [Figure 7](#))

Parameter		TEST CONDITIONS	MIN	TYP ⁽²⁾	MAX	UNIT
V _{OH}	High-level output voltage	All D _{OUT} at RL = 3kΩ to GND, D _{IN} = GND	5	5.4		V
V _{OL}	Low-level output voltage	All D _{OUT} at RL = 3kΩ to GND, D _{IN} = V _{CC}		-5.4	-5	V
I _{IH}	High-level input current	V _I = V _{CC}		±0.01	±1	μA
I _{IL}	Low-level input current	V _I at GND		±0.01	±1	μA
I _{OS}	Short-circuit output current ⁽³⁾	V _{CC} = 3.6V, V _O = 0V		±30	±60	mA
		V _{CC} = 5.5V, V _O = 0V		±30	±60	
r _O	Output resistance	V _{CC} , V _I , and V ₋ = 0V, V _O = ±2V	300	10M		Ω
I _{off}	Output leakage current	FORCEOFF = GND, V _O = ±12V, V _{CC} = 0 to 5.5V			±25	μA
		FORCEOFF = GND, V _O = ±12V, V _{CC} = 0 to 5.5V			±25	

(1) Test conditions are C1–C4 = 0.1μF at V_{CC} = 3.3V ± 0.3V; C1 = 0.047μF, C2–C4 = 0.33μF at V_{CC} = 5 V ± 0.5V.

(2) All typical values are at V_{CC} = 3.3V or V_{CC} = 5V, and T_A = 25°C.

(3) Short-circuit durations should be controlled to prevent exceeding the device absolute power dissipation ratings, and not more than one output should be shorted at a time.

5.7 Receiver Electrical Characteristics

over recommended ranges of supply voltage and operating free-air temperature (unless otherwise noted)⁽¹⁾
 (see [Figure 7](#))

Parameter		TEST CONDITIONS	MIN	TYP ⁽²⁾	MAX	UNIT
V _{OH}	High-level output voltage	I _{OH} = -1mA	V _{CC} - 0.6	V _{CC} - 0.1		V
V _{OL}	Low-level output voltage	I _{OH} = 1.6mA		0.1	0.4	V
V _{IT+}	Positive-going input threshold voltage	V _{CC} = 3.3 V		1.4	2.4	V
		V _{CC} = 5 V		1.7	2.4	
V _{IT-}	Negative-going input threshold voltage	V _{CC} = 3.3 V	0.6	1.1		V
		V _{CC} = 5 V	0.8	1.3		
V _{hys}	Input hysteresis (V _{IT+} - V _{IT-})			0.4		V
I _{off}	Output leakage current (except ROUT2B)	FORCEOFF = 0V		±0.03	±10	μA
ri	Input resistance	V _I = ±3 V or ±25V	3	6	8	kΩ

(1) Test conditions are C1-C4 = 0.1μF at V_{CC} = 3.3V ± 0.3 V; C1 = 0.047μF, C2-C4 = 0.33μF at V_{CC} = 5V ± 0.5V.

(2) All typical values are at V_{CC} = 3.3V or V_{CC} = 5V, and T_A = 25°C.

5.8 Auto-Powerdown Electrical Characteristics

over recommended ranges of supply voltage and operating free-air temperature (unless otherwise noted)⁽¹⁾
 (see [Figure 7](#))

Parameter		TEST CONDITIONS	MIN	TYP ⁽¹⁾	MAX	UNIT
V _{IT+(valid)}	Receiver input threshold for $\overline{\text{INVALID}}$ high-level output voltage	FORCEON = GND, FORCEOFF = V _{CC}			2.7	V
V _{IT-(valid)}	Receiver input threshold for $\overline{\text{INVALID}}$ high-level output voltage	FORCEON = GND, FORCEOFF = V _{CC}	-2.7			V
V _{T(invalid)}	Receiver input threshold for $\overline{\text{INVALID}}$ low-level output voltage	FORCEON = GND, FORCEOFF = V _{CC}	-0.3		0.3	V
V _{OH}	$\overline{\text{INVALID}}$ high-level output voltage	I _{OH} = -1mA, FORCEON = GND, FORCEOFF = V _{CC}	V _{CC} -0.6			V
V _{OL}	$\overline{\text{INVALID}}$ low-level output voltage	I _{OL} = 1.6mA, FORCEON = GND, FORCEOFF = V _{CC}			0.4	V

5.9 Driver Switching Characteristics

over recommended ranges of supply voltage and operating free-air temperature (unless otherwise noted)⁽¹⁾
 (see [Figure 7](#))

Parameter		TEST CONDITIONS	MIN	TYP ⁽²⁾	MAX	UNIT
	Maximum data rate	C _L = 1000pF, One D _{OUT} switching, R _L = 3kΩ. See Figure 1	125	250		kbit/s
t _{sk(p)}	Pulse skew ⁽³⁾	C _L = 150pF to 2500pF, R _L = 3kΩ to 7kΩ, See Figure 2		100		ns
SR _(tr)	Slew rate, transition region (see Figure 1)	V _{CC} = 3.3 V, R _L = 3kΩ to 7kΩ	C _L = 150pF to 1000pF	6	30	V/μs
			C _L = 150pF to 2500pF	4	30	

(1) Test conditions are C1-C4 = 0.1μF at V_{CC} = 3.3 V + 0.3 V; C1 = 0.047μF, C2-C4 = 0.33μF at V_{CC} = 5 V ± 0.5 V.

(2) All typical values are at V_{CC} = 3.3 V or V_{CC} = 5 V, and T_A = 25°C.

(3) Pulse skew is defined as |t_{PLH} - t_{PHL}| of each channel of the same device.

5.10 Receiver Switching Characteristics

over recommended ranges of supply voltage and operating free-air temperature (unless otherwise noted)⁽¹⁾
 (see Figure 7)

Parameter		TEST CONDITIONS	MIN	TYP ⁽²⁾	MIN	UNIT
t_{PLH}	Propagation delay time, low to high level output	$C_L = 150\text{pF}$, See Figure 3		30		ns
t_{PHL}	Propagation delay time, high to low level output	$C_L = 150\text{pF}$, See Figure 3		30		ns
t_{en}	Output enable time	$C_L = 150\text{pF}$, $R_L = 3\text{k}\Omega$, See Figure 4		200		ns
t_{dis}	Output disable time	$C_L = 150\text{pF}$, $R_L = 3\text{k}\Omega$, See Figure 4		200		ns
$t_{sk(p)}$	Pulse skew ⁽³⁾	$t_{sk(p)}$ Pulse skew ⁽³⁾ See Figure 3		10		ns

(1) Test conditions are $C1-C4 = 0.1\mu\text{F}$ at $V_{CC} = 3.3\text{V} \pm 0.3\text{V}$; $C1 = 0.047\mu\text{F}$, $C2-C4 = 0.33\mu\text{F}$ at $V_{CC} = 5\text{V} \pm 0.5\text{V}$.

(2) All typical values are at $V_{CC} = 3.3\text{V}$ or $V_{CC} = 5\text{V}$, and $T_A = 25^\circ\text{C}$.

(3) Pulse skew is defined as $|t_{PLH} - t_{PHL}|$ of each channel of the same device.

5.11 Auto-Powerdown Switching Characteristics

over recommended ranges of supply voltage and operating free-air temperature (unless otherwise noted)⁽¹⁾

Parameter		MIN	TYP ⁽¹⁾	MAX	UNIT
t_{valid}	Propagation delay time, low- to high-level output		1		μs
$t_{invalid}$	Propagation delay time, high- to low-level output		30		μs
t_{en}	Supply enable time		100		μs

(1) All typical values are at $V_{CC} = 3.3\text{V}$ or $V_{CC} = 5\text{V}$, and $T_A = 25^\circ\text{C}$.

6 Parameter Measurement Information

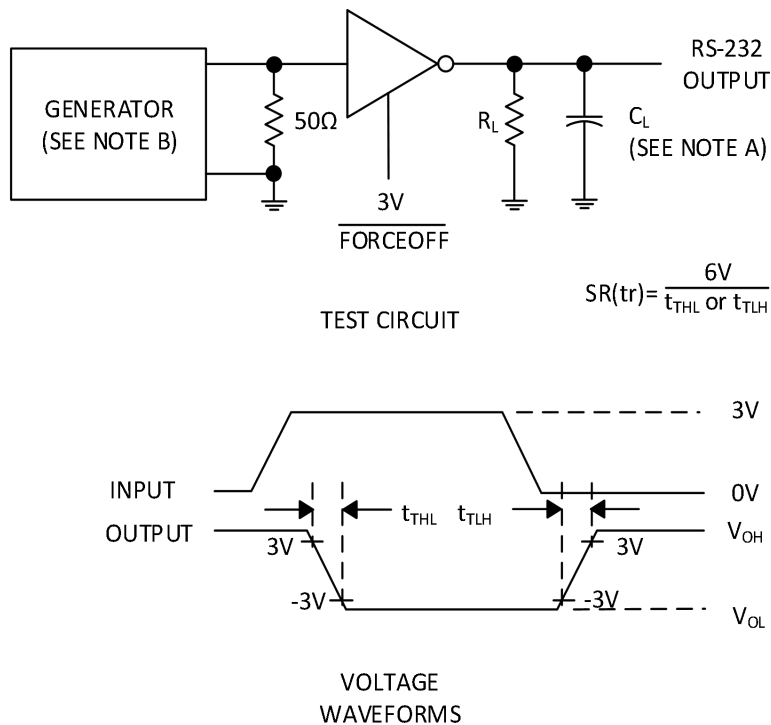

A. C_L includes probe and jig capacitance

B. The pulse generator has the following characteristics: PRR = 250kbit/s, $Z_0 = 50\Omega$, 50% duty cycle, $t_r \leq 10\text{ns}$, $t_f \leq 10\text{ns}$.

Figure 1. Driver Slew Rate

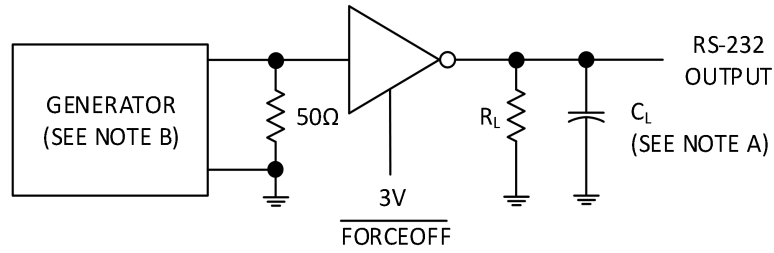

TEST CIRCUIT

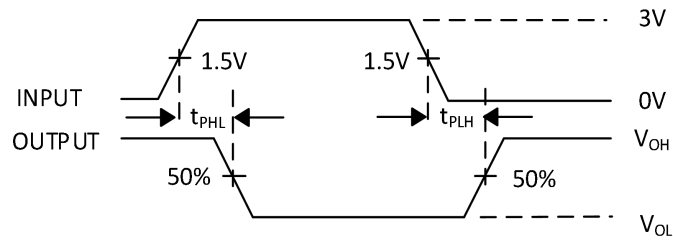
VOLTAGE
WAVEFORMS

A. C_L includes probe and jig capacitance

B. The pulse generator has the following characteristics: PRR = 250kbit/s, $Z_0 = 50\ \Omega$, 50 % duty cycle, $t_r \leq 10\text{ns}$, $t_f \leq 10\text{ns}$.

Figure 2. Driver Pulse Skew

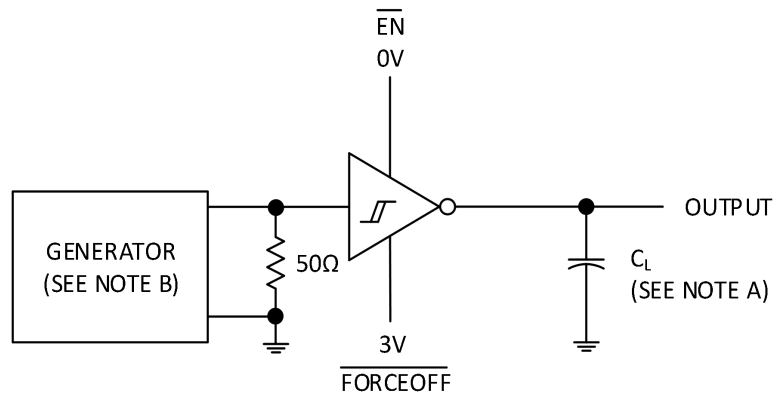

TEST CIRCUIT

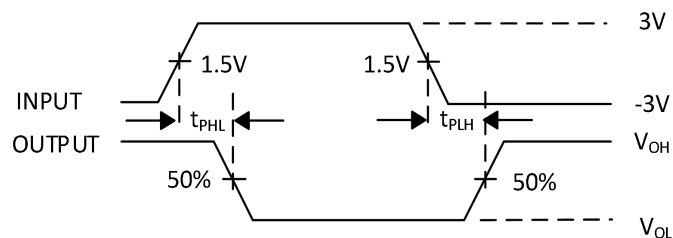
VOLTAGE
WAVEFORMS

A. C_L includes probe and jig capacitance

B. The pulse generator has the following characteristics: PRR = 250kbit/s, $Z_0 = 50\ \Omega$, 50 % duty cycle, $t_r \leq 10\text{ns}$, $t_f \leq 10\text{ns}$.

Figure 3. Receiver Propagation Delay Times

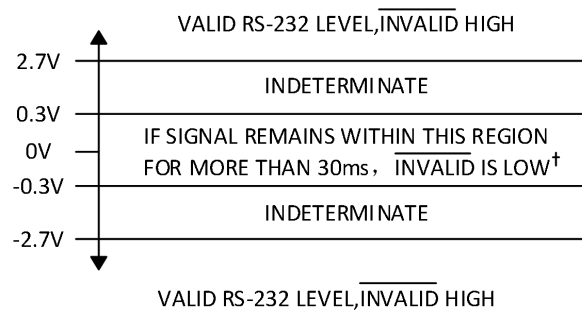
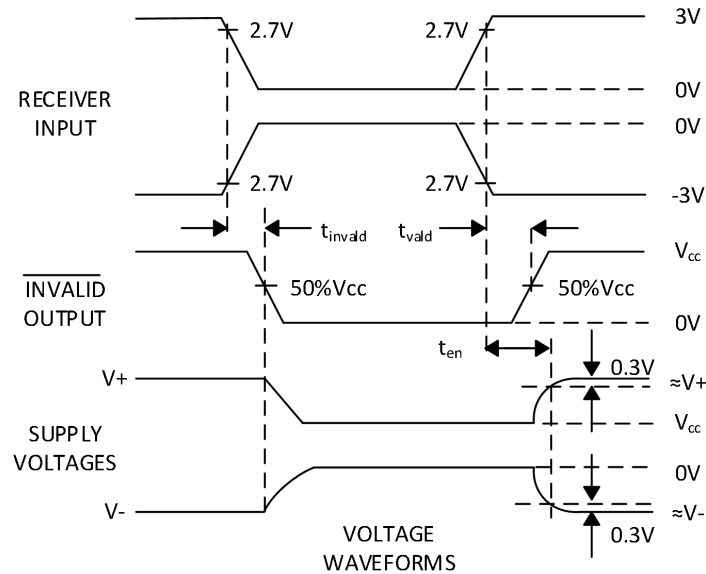

[†] AUTO-POWERDOWN DISABLES DRIVERS AND REDUCES SUPPLY CURRENT TO 1 μ A

A. CL includes probe and jig capacitance.

B. The pulse generator has the following characteristics: PRR = 5kbit/s, Z_O = 50 Ω , 50 % duty cycle, t_r \leq 10ns, t_f \leq 10ns.

Figure 5. INVALID Propagation Delay Times and Driver Enabling Time

7 Detailed Description

7.1 Overview

The GM3223E device is a one-driver and one-receiver RS-232 interface device. All RS-232 inputs and outputs are protected to ± 15 kV using the Human Body Model. The charge pump requires only four small 0.1 μ F capacitors for operation from a 3.3V supply. The GM3223E is capable of running at data rates up to 250kbps, while maintaining RS-232-compliant output levels.

Automatic power-down can be disabled when $\overline{\text{FORCEON}}$ and $\overline{\text{FORCEOFF}}$ are high. With automatic power down plus enabled, the device activates automatically when a valid signal is applied to any receiver input. The device can automatically power down the driver to save power when the RIN input is unpowered.

$\overline{\text{INVALID}}$ is high (valid data) if receiver input voltage is greater than 2.7V or less than -2.7V, or has been between -0.3 V and 0.3 V for less than 30 μ s. $\overline{\text{INVALID}}$ is low (invalid data) if receiver input voltages are between -0.3 V and 0.3 V for more than 30 μ s.

7.2 Functional Block Diagram

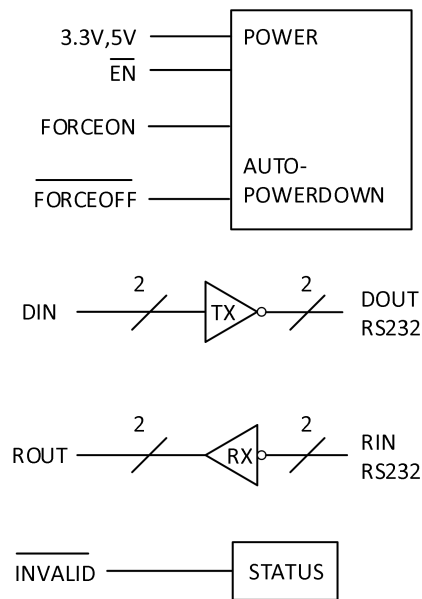

7.3 Feature Description

7.3.1 Power

The power block increases, inverts, and regulates voltage at V+ and V- pins using a charge pump that requires four external capacitors. Auto-power-down feature for driver is controlled by FORCEON and FORCEOFF inputs. Receiver is controlled by EN input. See [Table 1](#) and [Table 2](#).

When GM3223E is unpowered, it can be safely connected to an active remote RS232 device.

7.3.2 RS232 Driver

One driver interfaces standard logic level to RS232 levels. DIN input must be valid high or low.

7.3.3 RS232 Receiver

One receiver interfaces RS232 levels to standard logic levels. An open input will result in a high output on ROUT. RIN input includes an internal standard RS232 load. A logic high input on the EN pin will shutdown the receiver output.

7.3.3 RS232 Status

The INVALID output goes low when RIN input is unpowered for more than 30μs. The INVALID output goes high when receiver has a valid input. The INVALID output is active when Vcc is powered regardless of FORCEON and FORCEOFF inputs (see [Table 3](#)).

7.4 Device Functional Modes

Table 1 through 3 show the device functional modes.

Table 1. Each Driver

INPUTS ⁽¹⁾				OUTPUT	DRIVER STATUS
DIN	FORCEON	FORCEOFF	VALID RIN RS-232 LEVEL	DOUT	
X	X	L	X	Z	Powered off
L	H	H	X	H	Normal operation with auto-powerdown disabled
H	H	H	X	L	
L	L	H	Y	H	Normal operation with auto-powerdown enabled
H	L	H	Yes	L	
L	L	H	No	Z	Powered off by auto-powerdown feature
H	L	H	No	Z	

Table 2. Each Receiver

INPUTS ⁽¹⁾			OUTPUT	RECEIVER STATUS
RIN	EN	VALID RIN RS-232 LEVEL	ROUT	
X	H	X	Z	Powered off
L	L	X	H	Normal operation
H	L	X	L	
OPEN	L	No	H	

Table 3. INVALID

INPUTS ⁽¹⁾				OUTPUTS
RIN	FORCEON	FORCEOFF	EN	INVALID
L	X	X	X	H
H	X	X	X	H
OPEN	X	X	X	L

(1) H = high level, L = low level, X = irrelevant, Z = high impedance (off), Open = input disconnected or connected driver off.

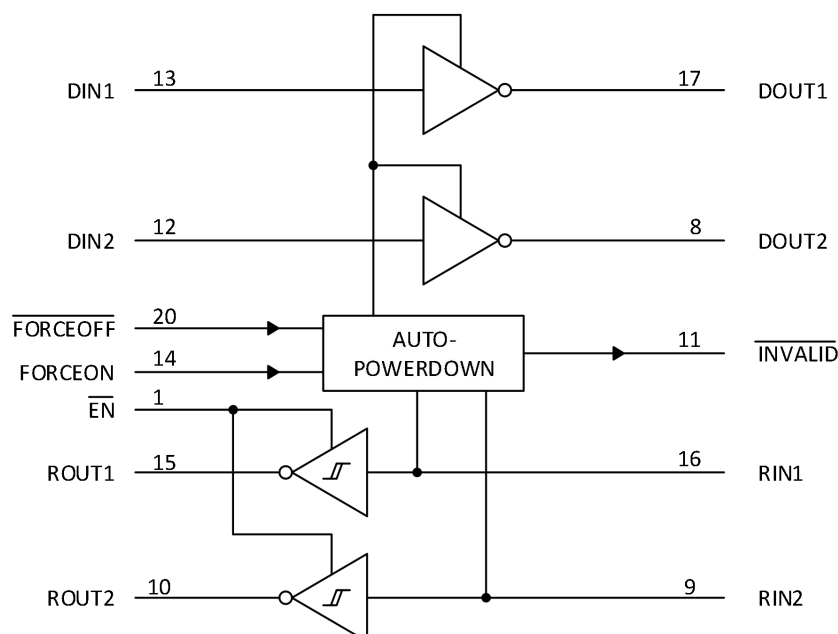

Figure 6. Logic Diagram

8 Applications Information

8.1 Application Information

The GM3223E line driver and receiver is a specialized device for 3V to 5.5V RS-232 communication applications. This application is a generic implementation of this device with all required external components. For proper operation, add capacitors as shown in [Figure 7](#).

8.2 Typical Application

ROUT and DIN connect to UART or general purpose logic lines. FORCEON and $\overline{\text{FORCEOFF}}$ may be connected general purpose logic lines or tied to ground or V_{CC} . $\overline{\text{INVALID}}$ may be connected to a general purpose logic line or left unconnected. RIN and DOUT lines connect to a RS232 connector or cable. DIN, FORCEON, and $\overline{\text{FORCEOFF}}$ inputs must not be left unconnected.

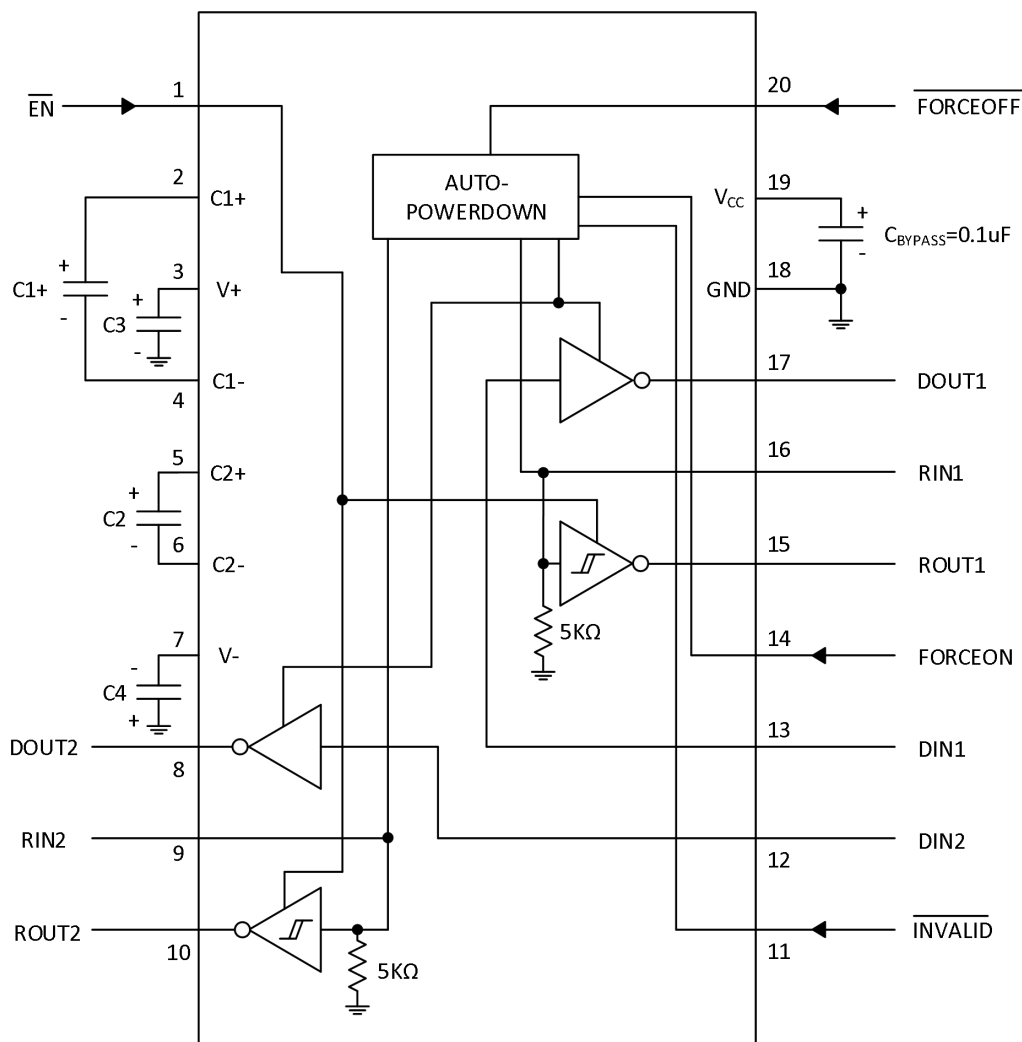

†: C3 can be connected to V_{CC} or GND

A. Resistor values shown are nominal.

B. Nonpolarized ceramic capacitors are acceptable. If polarized tantalum or electrolytic capacitors are used, they should be connected as shown.

Figure 7. Typical Operating Circuit and Capacitor Values

8.2.1 Design Requirements

For this design example, use the values in [Table 4](#).

- V_{CC} minimum is 3V and maximum is 5.5V.
- Maximum recommended bit rate is 250kbps.
- Recommend capacitors as shown in Table 4.

Table 4. V_{CC} vs Capacitor Values

V _{CC}	C1	C2, C3, and C4
3.3V ± 0.3V	0.1μF	0.1μF
5V ± 0.5V	0.047μF	0.33μF
3V to 5.5V	0.1μF	0.47μF

8.2.2 Detailed Design Procedure

GM3223E has integrated charge-pump that generates positive and negative rails needed for RS-232 signal levels. Main design requirement is that charge-pump capacitor terminals must be connected with recommended capacitor values. Charge-pump rail voltages and device supply pin must be properly bypassed with ceramic capacitors.

- DIN, $\overline{\text{FORCEOFF}}$ and FORCEON inputs must be connected to valid low or high logic levels.
- Select capacitor values based on V_{CC} level for best performance.

9 Power Supply Recommendations

The V_{CC} voltage must be connected to the same power source used for logic device connected to DIN and ROUT pins. V_{CC} must be between 3V and 5.5V.

10 Layout

As shown in Layout Example, charge-pump and supply voltage capacitors must be located very close to device pins. Non-polarized ceramic capacitors are recommended. If polarized tantalum or electrolytic capacitors are used, they should be connected as per Typical Operating Circuit and Capacitor Values.

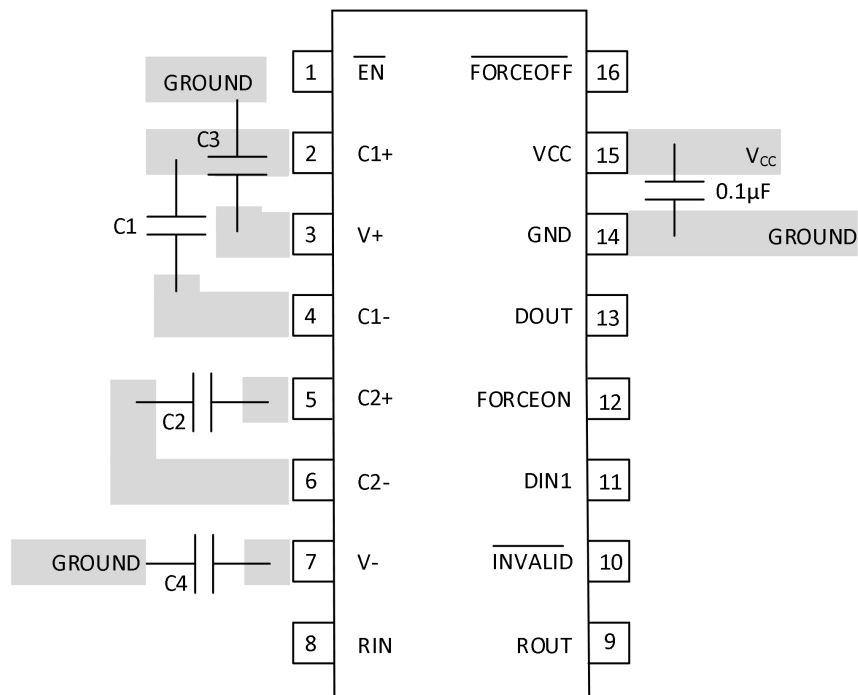
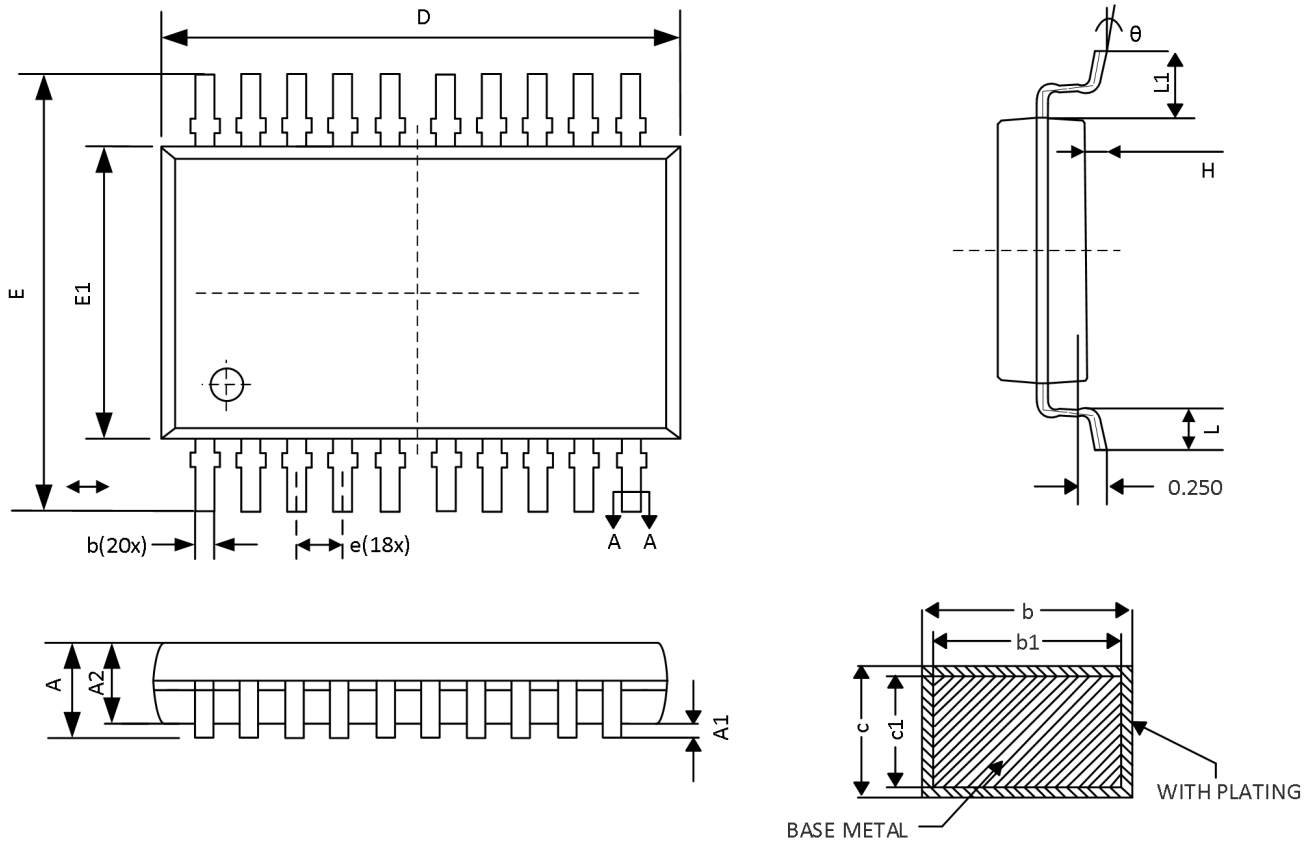
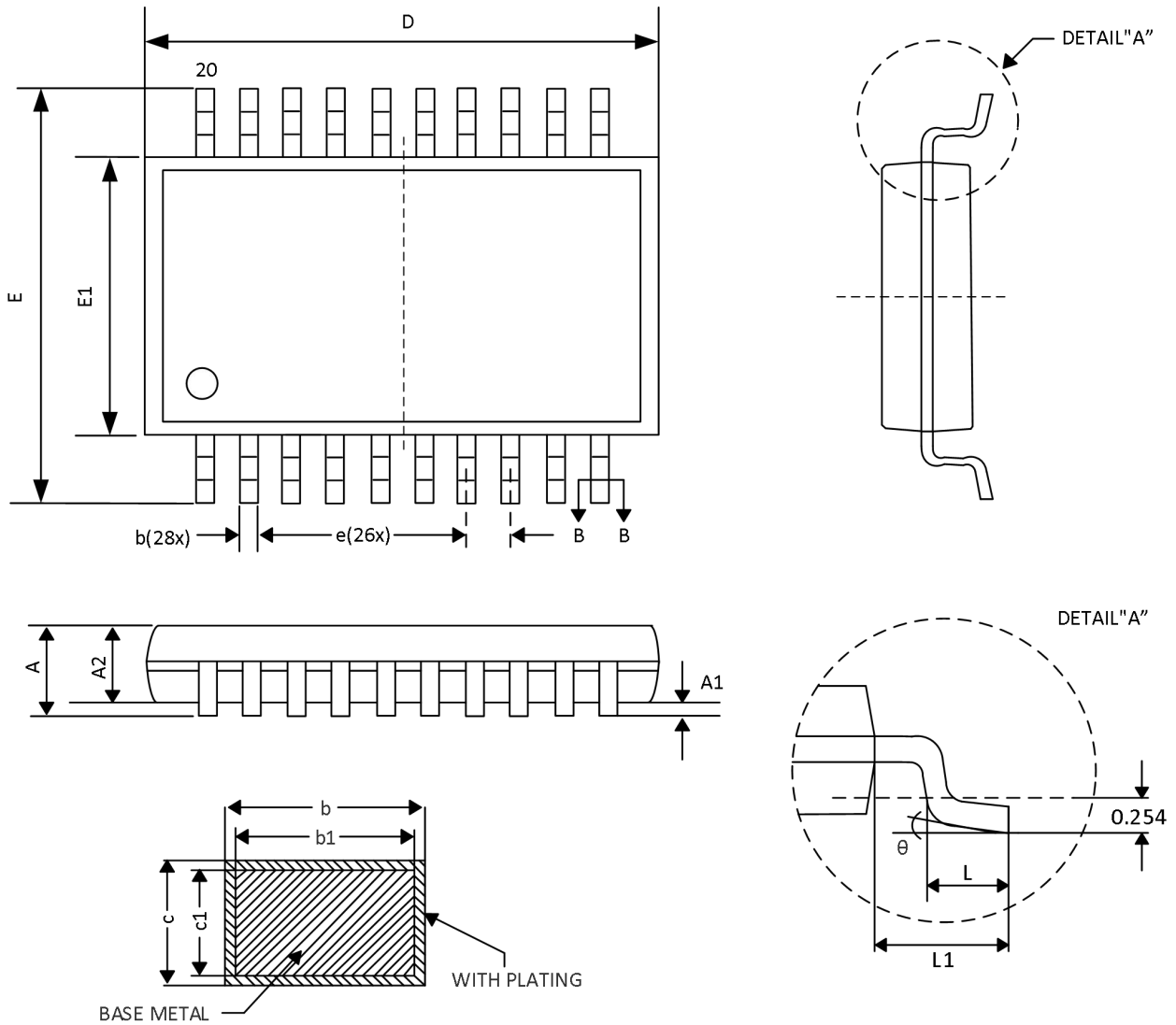

Figure 8. Example Layout

PACKAGE DIMENSION
TSSOP20

	SYMBOL	MIN	NOM	MAX
TOTAL THICKNESS	A	-	-	1.20
STAND OFF	A1	0.05	0.100	0.15
MOLD TOTAL THICKNESS	A2	0.90	1.00	1.05
LEAD WIDTH-1	b	0.20	-	0.28
LEAD WIDTH-2	b1	0.19	0.22	0.25
LEAD THICKNESS-1	c	0.13	-	0.17
LEAD THICKNESS-2	C1	0.120	0.127	0.14
MOLD LENGTH	D	6.40	6.50	6.60
LEAD SPAN	E	6.20	6.40	6.60
MOLD WIDTH	E1	4.30	4.40	4.50
LEAD PITCH	e	0.65BSC		
LEAD LENGTH	L1	0.85	1.00	1.15
LEAD SOLE LENGTH	L	0.45	0.60	0.75
LEAD FORM ANGLE	θ	0°	-	8°

SSOP20



SYMBOL	DIM	MIN	NOM	MAX
A		1.65	-	1.85
A1		0.05	-	0.25
A2		1.45	-	1.55
b		0.28	-	0.36
B1		0.30BSC		
c		0.15	-	0.19
C1		0.152BSC		
D		7.15	-	7.25
E		7.65	-	7.95
E1		5.25	-	5.35
e		0.65BSC		
L		0.60	-	0.80
L1		1.25TYPE		
θ		0°	-	8°

Order Information

Order number	Package	Marking information	Operation Temperature Range	MSL Grade	Ship, Quantity	Green
GM3223ETA	TSSOP20	GM3223ETA	-40 to 85°C	3	T&R, 2500	Rohs
GM3223EBA	SSOP20	GM3223EBA	-40 to 85°C	3	T&R, 2500	Rohs