

1. DESCRIPTION

These devices are precision timing circuits capable of producing accurate time delays or oscillation. In the time-delay or mono-stable mode of operation, the timed interval is controlled by a single external resistor and capacitor network. In the a-stable mode of operation, the frequency and duty cycle can be controlled independently with two external resistors and a single external capacitor.

The threshold and trigger levels normally are two-thirds and one-third, respectively, of V_{CC} . These levels can be altered by use of the control-voltage terminal. When the trigger input falls below the trigger level, the flip-flop is set, and the output goes high. If the trigger input is above the trigger level and the threshold input is above the threshold level, the flip-flop is reset and the output is low. The reset (RESET) input can override all other inputs and can be used to initiate a new timing cycle. When RESET goes low, the flip-flop is reset, and the output goes low. When the output is low, a low-impedance path is provided between discharge (DISCH) and ground.

The output circuit is capable of sinking or sourcing current up to 200 mA. Operation is specified for supplies of 5 V to 15 V. With a 5-V supply, output levels are compatible with TTL inputs.

2. FEATURES

- Timing From Microseconds to Hours
- Astable or Monostable Operation
- Adjustable Duty Cycle
- TTL-Compatible Output Can Sink or Source Up to 200 mA
- On Products Compliant to MIL-PRF-38535, All Parameters Are Tested Unless Otherwise Noted.
On All Other Products, Production Processing Does Not Necessarily Include Testing of All Parameters.

3. APPLICATIONS

- Fingerprint Biometrics
- Iris Biometrics
- RFID Reader

4. SIMPLIFIED SCHEMATIC

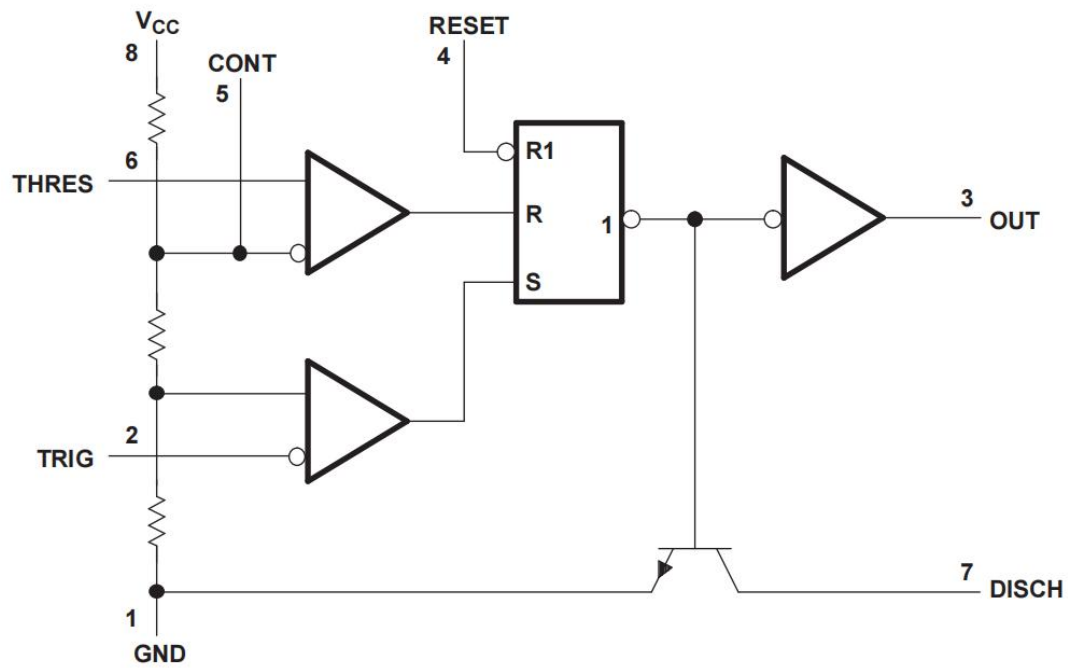

5. PIN CONFIGURATION AND FUNCTIONS

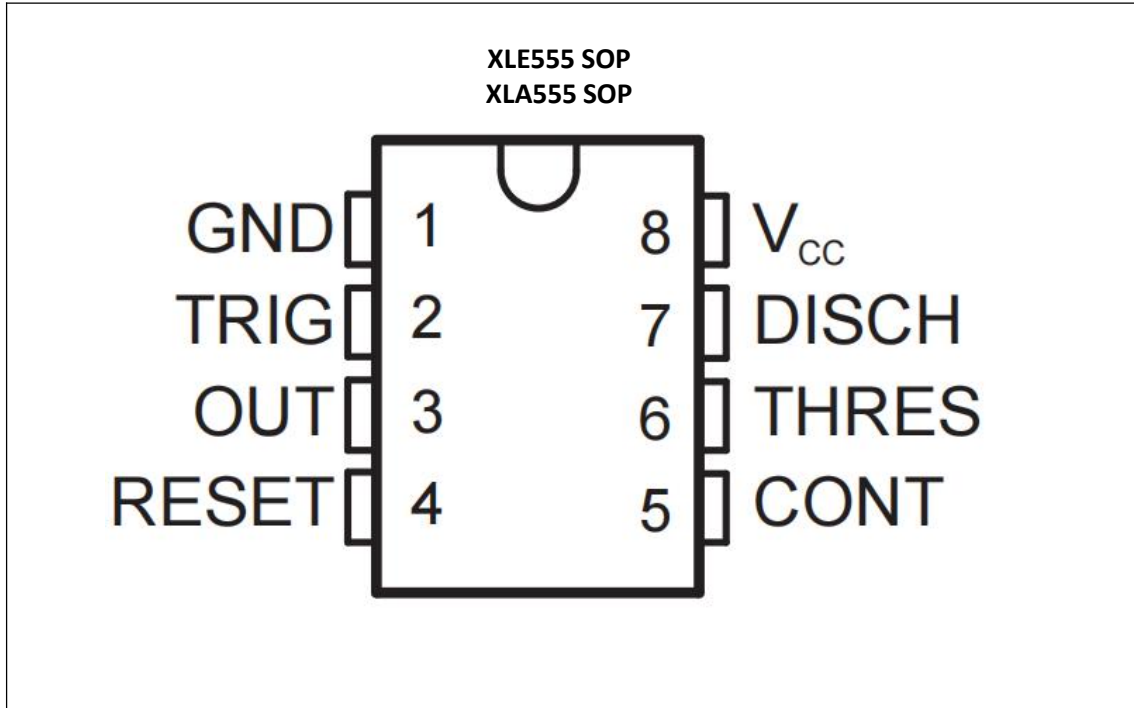

PIN		I/O	DESCRIPTION
NAME	NO.		
CONT	5	I/O	Controls comparator thresholds, Outputs 2/3 V _{CC} , allows bypass capacitor connection
DISCH	7	O	Open collector output to discharge timing capacitor
GND	1	–	Ground
OUT	3	O	High current timer output signal
RESET	4	I	Active low reset input forces output and discharge low.
THRES	6	I	End of timing input. THRES > CONT sets output low and discharge low
TRIG	2	I	Start of timing input. TRIG < ½ CONT sets output high and discharge open
V _{CC}	8	–	Input supply voltage, 4.5 V to 16 V.

6. SPECIFICATIONS

6.1. Absolute Maximum Ratings⁽¹⁾

over operating free-air temperature range (unless otherwise noted)

			MIN	MAX	UNIT
V _{CC}	Supply voltage ⁽²⁾			18	V
V _I	Input voltage	CONT, RESET, THRES, TRIG		V _{CC}	V
I _O	Output current			±225	mA
θ _{JA}	Package thermal impedance ⁽³⁾⁽⁴⁾	SOP package		85	°C/W
T _J	Operating virtual junction temperature			150	°C

(1) Stresses beyond those listed under Absolute Maximum Ratings may cause permanent damage to the device. These are stress ratings only, and functional operation of the device at these or any other conditions beyond those indicated under Recommended Operating Conditions is not implied. Exposure to absolute-maximum-rated conditions for extended periods may affect device reliability.

(2) All voltage values are with respect to GND.

(3) Maximum power dissipation is a function of T_J (max), θ_{JA}, and T_A. The maximum allowable power dissipation at any allowable ambient temperature is P_D = (T_J (max) - T_A) / θ_{JA}. Operating at the absolute maximum T_J of 150°C can affect reliability.

(4) The package thermal impedance is calculated in accordance with JEDEC 51-7.

6.2. Handling Ratings

PARAMETER	DEFINITION	MIN	MAX	UNIT
T _{stg}	Storage temperature range	-65	150	°C

6.3. Recommended Operating Conditions

over operating free-air temperature range (unless otherwise noted)

			MIN	MAX	UNIT
V _{CC}	Supply voltage	XLE555, XLA55	4.5	16	V
V _I	Input voltage	CONT, RESET, THRES, and TRIG		V _{CC}	
I _O	Output current			±200	mA
T _A	Operating free-air temperature	XLE555	-40	85	°C
		XLA555	-40	85	

6.4. Electrical Characteristics

$V_{CC} = 5\text{ V}$ to 15 V , $T_A = 25^\circ\text{C}$ (unless otherwise noted)

PARAMETER	TEST CONDITIONS	XLE555 XLA555			UNIT
		MIN	TYP	MAX	
THRES voltage level	$V_{CC} = 15\text{ V}$	8.8	10	11.2	V
	$V_{CC} = 5\text{ V}$	2.4	3.3	4.2	
THRES current ⁽¹⁾			30	250	nA
TRIG voltage level	$V_{CC} = 15\text{ V}$	4.5	5	5.6	V
	$V_{CC} = 5\text{ V}$	1.1	1.67	2.2	
TRIG current	TRIG at 0 V		0.5	2	μA
RESET voltage level		0.3	0.7	1	V
RESET current	RESET at V_{CC}		0.1	0.4	mA
	RESET at 0 V		-0.4	-1.5	
DISCH switch off-state current			20	100	nA
DISCH switch on-state voltage	$V_{CC} = 5\text{ V}$, $I_O = 8\text{ mA}$		0.15	0.4	V
CONT voltage (open circuit)	$V_{CC} = 15\text{ V}$	9	10	11	V
	$V_{CC} = 5\text{ V}$	2.6	3.3	4	
Low-level output voltage	$V_{CC} = 15\text{ V}$, $I_{OL} = 10\text{ mA}$		0.1	0.25	V
	$V_{CC} = 15\text{ V}$, $I_{OL} = 50\text{ mA}$		0.4	0.75	
	$V_{CC} = 15\text{ V}$, $I_{OL} = 100\text{ mA}$		2	2.5	
	$V_{CC} = 15\text{ V}$, $I_{OL} = 200\text{ mA}$		2.5		
	$V_{CC} = 5\text{ V}$, $I_{OL} = 5\text{ mA}$		0.1	0.35	
	$V_{CC} = 5\text{ V}$, $I_{OL} = 8\text{ mA}$		0.15	0.4	
High-level output voltage	$V_{CC} = 15\text{ V}$, $I_{OH} = -100\text{ mA}$	12.75	13.3		V
	$V_{CC} = 15\text{ V}$, $I_{OH} = -200\text{ mA}$		12.5		
	$V_{CC} = 5\text{ V}$, $I_{OH} = -100\text{ mA}$	2.75	3.3		
Supply current	Output low, No load	$V_{CC} = 15\text{ V}$	10	15	mA
		$V_{CC} = 5\text{ V}$	3	6	
	Output high, No load	$V_{CC} = 15\text{ V}$	9	13	
		$V_{CC} = 5\text{ V}$	2	5	

NOTE 1: This parameter influences the maximum value of the timing resistors R_A and R_B in the circuit of [Figure 12](#). For example, when $V_{CC} = 5\text{ V}$, the maximum value is $R = R_A + R_B \approx 3.4\text{ M}\Omega$, and for $V_{CC} = 15\text{ V}$, the maximum value is $10\text{ M}\Omega$.

6.5. Operating Characteristics

$V_{CC} = 5\text{ V to }15\text{ V}$, $T_A = 25^\circ\text{C}$ (unless otherwise noted)

PARAMETER		TEST CONDITIONS ⁽¹⁾	XLE555 XLA555			UNIT
			MIN	TYP	MAX	
Initial error of timing interval ⁽²⁾	Each timer, monostable ⁽³⁾	$T_A = 25^\circ\text{C}$		1	3	%
	Each timer, astable ⁽⁵⁾			2.25		
Temperature coefficient of timing interval	Each timer, monostable ⁽³⁾	$T_A = \text{MIN to MAX}$		50		ppm/ °C
	Each timer, astable ⁽⁵⁾			150		
Supply-voltage sensitivity of timing interval	Each timer, monostable ⁽³⁾	$T_A = 25^\circ\text{C}$		0.1	0.5	%/V
	Each timer, astable ⁽⁵⁾			0.3		
Output-pulse rise time		$C_L = 15\text{ pF}$, $T_A = 25^\circ\text{C}$		100	300	ns
Output-pulse fall time		$C_L = 15\text{ pF}$, $T_A = 25^\circ\text{C}$		100	300	ns

(1) For conditions shown as MIN or MAX, use the appropriate value specified under recommended operating conditions.

(2) Timing interval error is defined as the difference between the measured value and the average value of a random sample from each process run.

(3) Values specified are for a device in a monostable circuit similar to [Figure 9](#), with the following component values: $R_A = 2\text{ k}\Omega$ to $100\text{ k}\Omega$, $C = 0.1\text{ }\mu\text{F}$.

(4) On products compliant to MIL-PRF-38535, this parameter is not production tested.

(5) Values specified are for a device in an astable circuit similar to [Figure 12](#), with the following component values: $R_A = 1\text{ k}\Omega$ to $100\text{ k}\Omega$, $C = 0.1\text{ }\mu\text{F}$.

7. DETAILED DESCRIPTION

7.1. Overview

The xx555 timer is a popular and easy to use for general purpose timing applications from 10 μ s to hours or from < 1mHz to 100 kHz. In the time-delay or mono-stable mode of operation, the timed interval is controlled by a single external resistor and capacitor network. In the a-stable mode of operation, the frequency and duty cycle can be controlled independently with two external resistors and a single external capacitor. Maximum output sink and discharge sink current is greater for higher V_{CC} and less for lower V_{CC} .

7.2. Functional Block Diagram

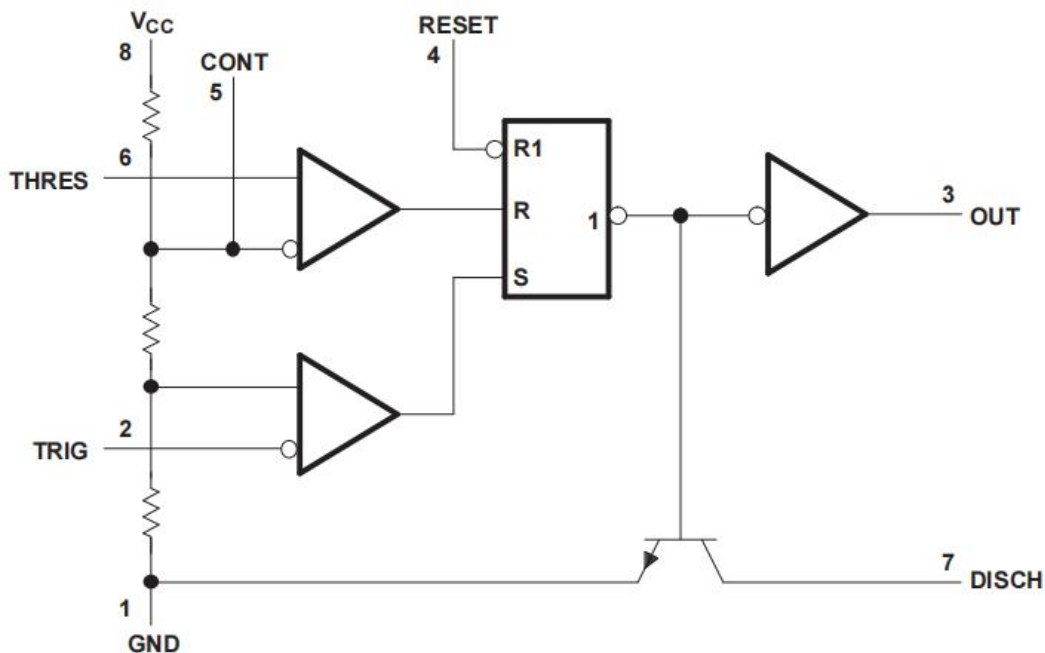

A. RESET can override TRIG, which can override THRES.

7.3. Feature Description

7.3.1. Mono-stable Operation

For mono-stable operation, any of these timers can be connected as shown in [Figure 1](#). If the output is low, application of a negative-going pulse to the trigger (TRIG) sets the flip-flop (Q goes low), drives the output high, and turns off Q1. Capacitor C then is charged through RA until the voltage across the capacitor reaches the threshold voltage of the threshold (THRES) input. If TRIG has returned to a high level, the output of the threshold comparator resets the flip-flop (Q goes high), drives the output low, and discharges C through Q1.

Feature Description (continued)

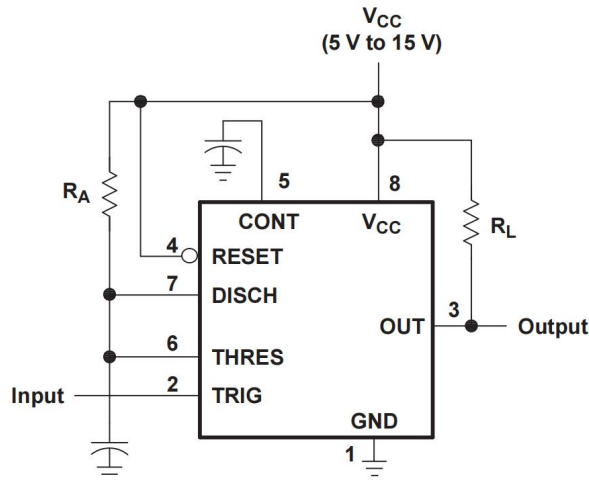

Pin numbers shown are for the D, JG, P, PS, and PW packages.

Figure 1. Circuit for Monostable Operation

Monostable operation is initiated when TRIG voltage falls below the trigger threshold. Once initiated, the sequence ends only if TRIG is high for at least 10 μ s before the end of the timing interval. When the trigger is grounded, the comparator storage time can be as long as 10 μ s, which limits the minimum monostable pulse width to 10 μ s. Because of the threshold level and saturation voltage of Q1, the output pulse duration is approximately $t_w = 1.1R_A C$. Figure 3 is a plot of the time constant for various values of R_A and C. The threshold levels and charge rates both are directly proportional to the supply voltage, V_{CC} . The timing interval is, therefore, independent of the supply voltage, so long as the supply voltage is constant during the time interval.

Applying a negative-going trigger pulse simultaneously to RESET and TRIG during the timing interval discharges C and reinitiates the cycle, commencing on the positive edge of the reset pulse. The output is held low as long as the reset pulse is low. To prevent false triggering, when RESET is not used, it should be connected to V_{CC} .

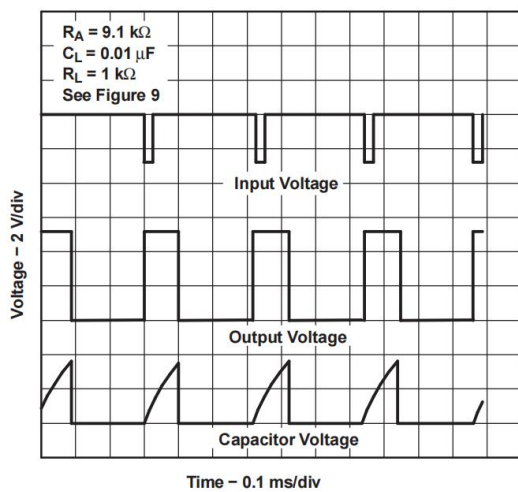

Figure 2. Typical Monostable Waveforms

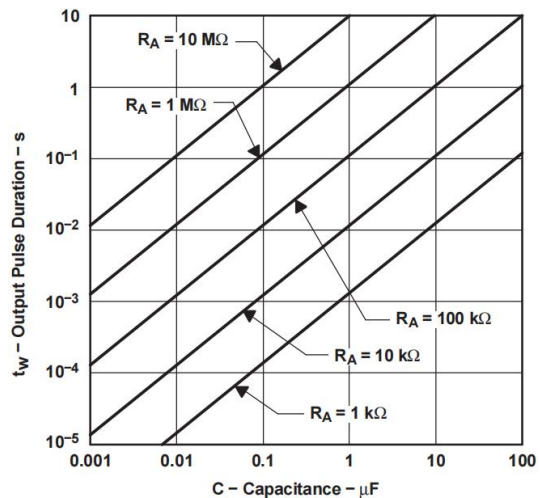

Figure 3. Output Pulse Duration vs Capacitance

Feature Description (continued)

7.3.2. A-stable Operation

As shown in Figure 4, adding a second resistor, RB, to the circuit of Figure 1 and connecting the trigger input to the threshold input causes the timer to self-trigger and run as a multi-vibrator. The capacitor C charges through RA and RB and then discharges through RB only. Therefore, the duty cycle is controlled by the values of RA and RB.

This astable connection results in capacitor C charging and discharging between the threshold-voltage level ($\approx 0.67 \times V_{CC}$) and the trigger-voltage level ($\approx 0.33 \times V_{CC}$). As in the mono-stable circuit, charge and discharge times (and, therefore, the frequency and duty cycle) are independent of the supply voltage.

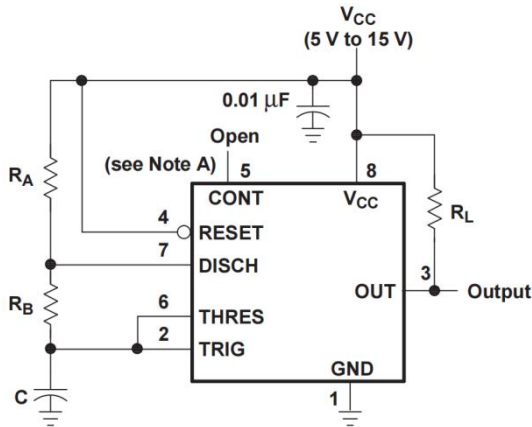

NOTE A: Decoupling CONT voltage to ground with a capacitor can improve operation. This should be evaluated for individual

Figure 4. Circuit for Astable Operation

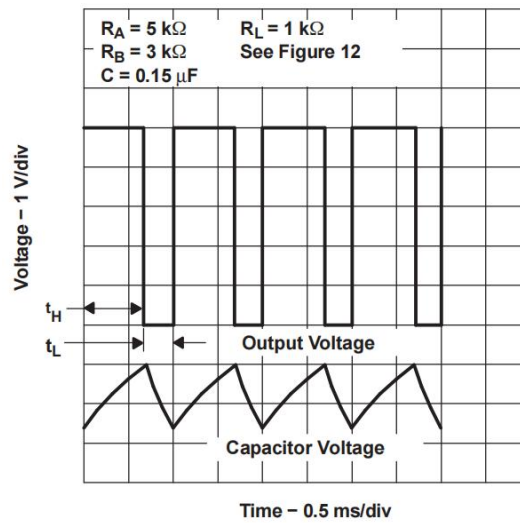

Figure 5. Typical Astable Waveforms

Figure 4 shows typical waveforms generated during astable operation. The output high-level duration tH and low-level duration tL can be calculated as follows:

$$t_H = 0.693(R_A + R_B)C \tag{1}$$

$$t_L = 0.693(R_B)C \tag{2}$$

Other useful relationships are shown below:

$$\text{period} = t_H + t_L = 0.693(R_A + 2R_B)C \tag{3}$$

$$\text{frequency} \approx \frac{1.44}{(R_A + 2R_B)C} \tag{4}$$

$$\text{Output driver duty cycle} = \frac{t_L}{t_H + t_L} = \frac{R_B}{R_A + 2R_B} \tag{5}$$

$$\text{Output waveform duty cycle} = \frac{t_H}{t_H + t_L} = 1 - \frac{R_B}{R_A + 2R_B} \tag{6}$$

$$\text{Low-to-high ratio} = \frac{t_L}{t_H} = \frac{R_B}{R_A + R_B} \tag{7}$$

Feature Description (continued)

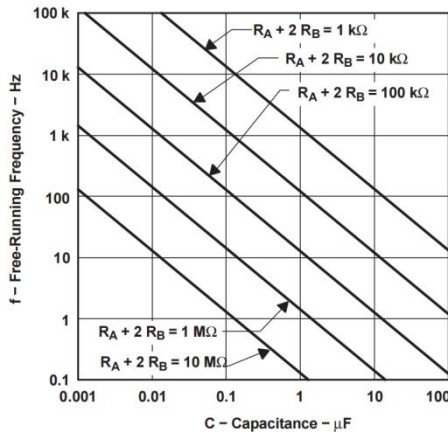

Figure 6. Free-Running Frequency

7.3.3. Frequency Divider

By adjusting the length of the timing cycle, the basic circuit of Figure 1 can be made to operate as a frequency divider. Figure 7 shows a divide-by-three circuit that makes use of the fact that re-triggering cannot occur during the timing cycle.

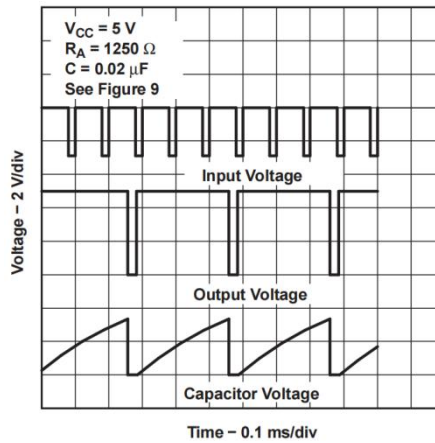

Figure 15. Divide-by-Three Circuit Waveforms

7.4. Device Functional Modes

Table 1. Function Table

RESET	TRIGGER VOLTAGE ⁽¹⁾	THRESHOLD VOLTAGE ⁽¹⁾	OUTPUT	DISCHARGE SWITCH
Low	Irrelevant	Irrelevant	Low	On
High	<1/3 V _{CC}	Irrelevant	High	Off
High	>1/3 V _{CC}	>2/3 V _{CC}	Low	On
High	>1/3 V _{CC}	<2/3 V _{CC}	As previously established	

(1) Voltage levels shown are nominal.

8. APPLICATIONS AND IMPLEMENTATION

8.1. Application Information

The xx555 timer devices use resistor and capacitor charging delay to provide a programmable time delay or operating frequency. This section presents a simplified discussion of the design process.

8.2. Typical Applications

8.2.1. Missing-Pulse Detector

The circuit shown in Figure 8 can be used to detect a missing pulse or abnormally long spacing between consecutive pulses in a train of pulses. The timing interval of the monostable circuit is re-triggered continuously by the input pulse train as long as the pulse spacing is less than the timing interval. A longer pulse spacing, missing pulse, or terminated pulse train permits the timing interval to be completed, thereby generating an output pulse as shown in Figure 9.

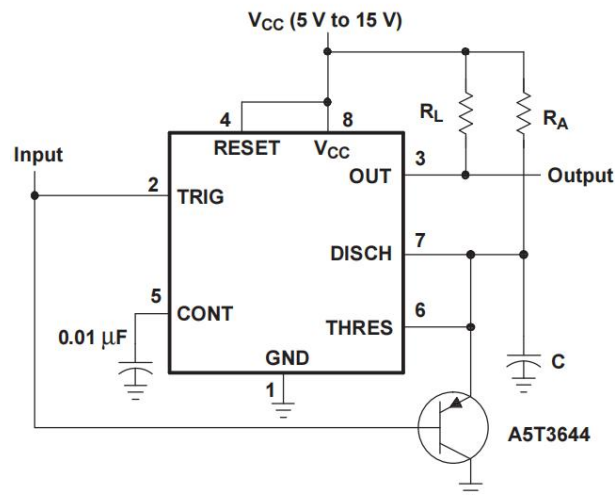

Figure 8. Circuit for Missing-Pulse Detector

8.2.1.1. Design Requirements

Input fault (missing pulses) must be input high. Input stuck low will not be detected because timing capacitor "C" will remain discharged.

8.2.1.2. Detailed Design Procedure

Choose RA and C so that $RA \times C > [\text{maximum normal input high time}]$. RL improves VOH, but it is not required for TTL compatibility.

8.2.1.3. Application Curves

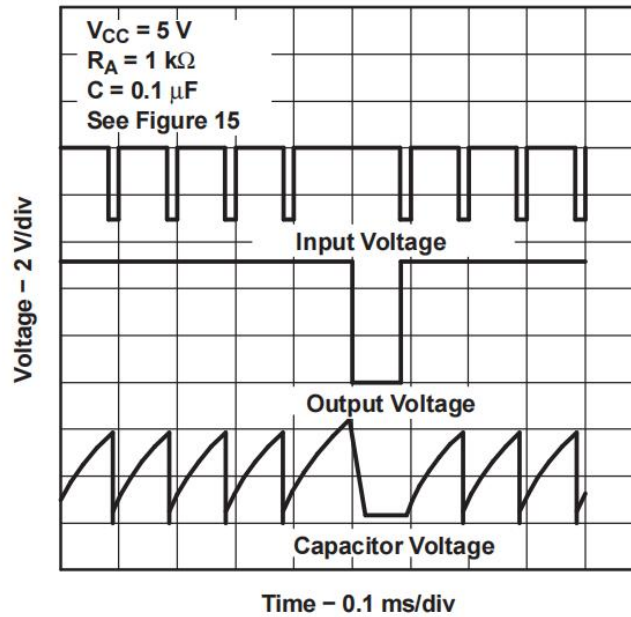
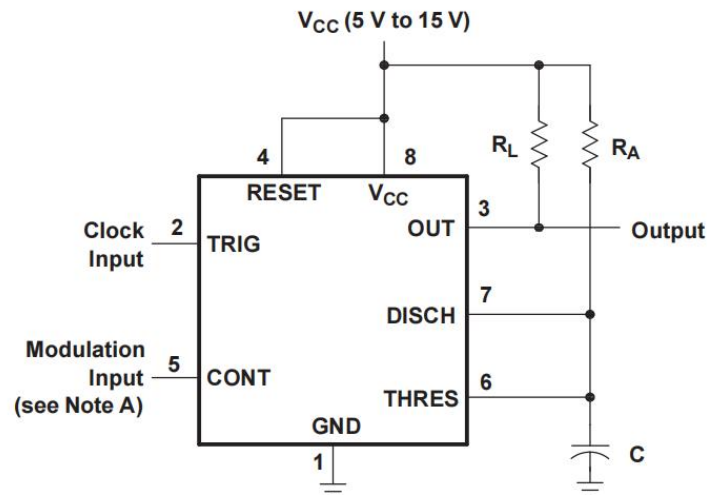

Figure 9. Completed Timing Waveforms for Missing-Pulse Detector

8.2.2. Pulse-Width Modulation

The operation of the timer can be modified by modulating the internal threshold and trigger voltages, which is accomplished by applying an external voltage (or current) to CONT. Figure 10 shows a circuit for pulse-width modulation. A continuous input pulse train triggers the monostable circuit, and a control signal modulates the threshold voltage. Figure 11 shows the resulting output pulse-width modulation. While a sine-wave modulation signal is shown, any wave shape could be used.



NOTE A: The modulating signal can be direct or capacitively coupled to CONT. For direct coupling, the effects of modulation source voltage and impedance on the bias of the timer should be considered.

Figure 10. Circuit for Pulse-Width Modulation

8.2.2.1. Design Requirements

Clock input must have V_{OL} and V_{OH} levels that are less than and greater than $1/3 V_{CC}$. Modulation input can vary from ground to V_{CC} . The application must be tolerant of a nonlinear transfer function; the relationship between modulation input and pulse width is not linear because the capacitor charge is based RC on an negative exponential curve.

8.2.2.2. Detailed Design Procedure

Choose R_A and C so that $R_A \times C = 1/4$ [clock input period]. R_L improves V_{OH} , but it is not required for TTL compatibility.

8.2.2.3. Application Curves

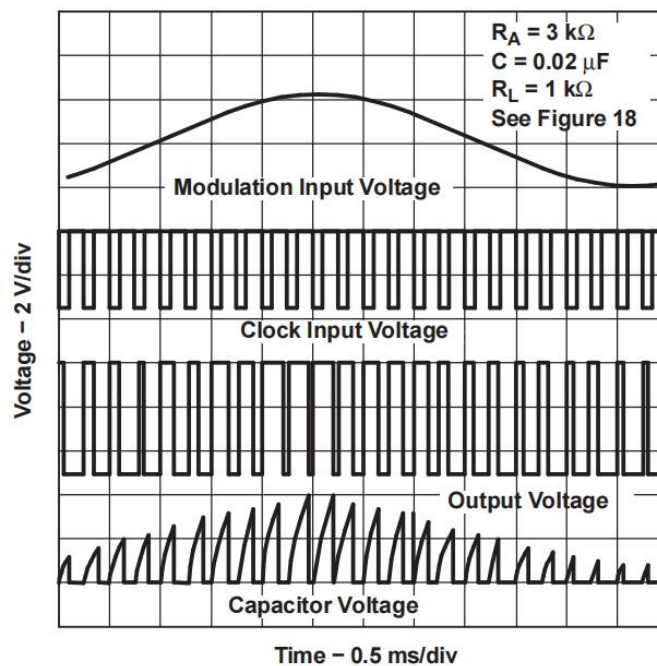
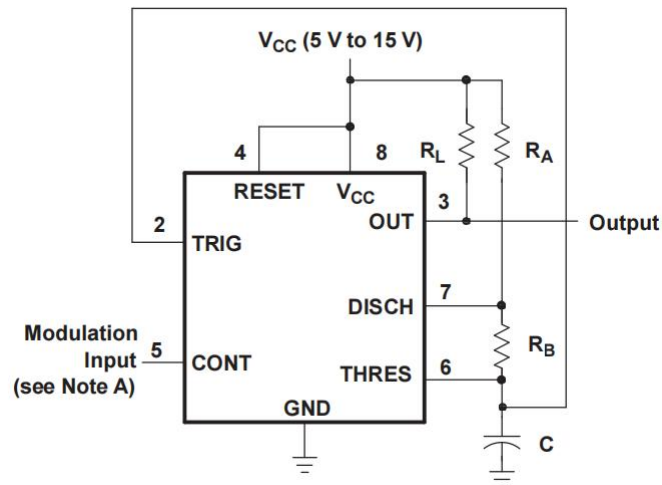

Figure 11. Pulse-Width-Modulation Waveforms

8.2.3. Pulse-Position Modulation

As shown in [Figure 12](#), any of these timers can be used as a pulse-position modulator. This application modulates the threshold voltage and, thereby, the time delay, of a free-running oscillator. [Figure 13](#) shows a triangular-wave modulation signal for such a circuit; however, any wave shape could be used.



NOTE A: The modulating signal can be direct or capacitively coupled to CONT. For direct coupling, the effects of modulation source voltage and impedance on the bias of the timer should be considered.

Figure 12. Circuit for Pulse-Position Modulation

8.2.3.1. Design Requirements

Both DC and AC coupled modulation input will change the upper and lower voltage thresholds for the timing capacitor. Both frequency and duty cycle will vary with the modulation voltage.

8.2.3.2. Detailed Design Procedure

The nominal output frequency and duty cycle can be determined using formulas in A-stable Operation section. R_L improves V_{OH} , but it is not required for TTL compatibility.

8.2.3.3. Application Curves

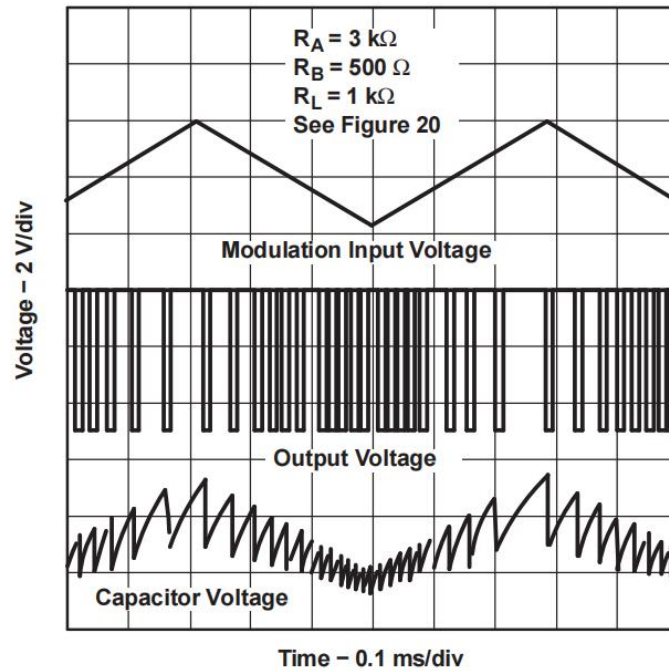
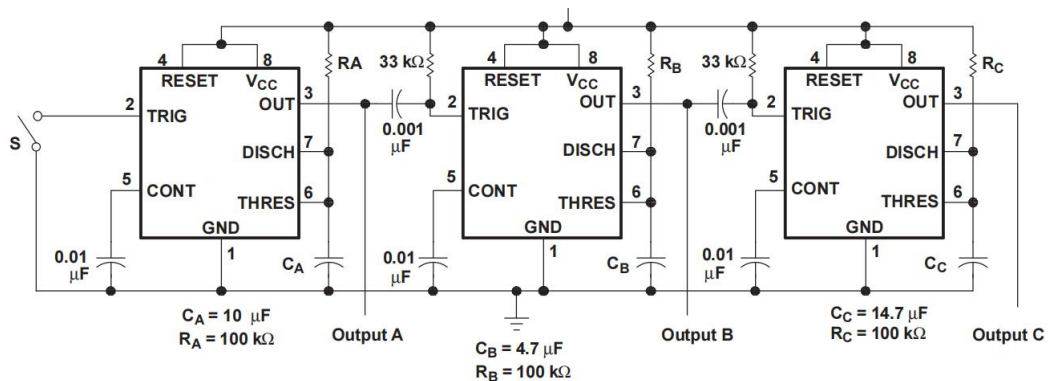

Figure 13. Pulse-Position-Modulation Waveforms

8.2.4. Sequential Timer

Many applications, such as computers, require signals for initializing conditions during start-up. Other applications, such as test equipment, require activation of test signals in sequence. These timing circuits can be connected to provide such sequential control. The timers can be used in various combinations of astable or monostable circuit connections, with or without modulation, for extremely flexible waveform control. [Figure 14](#) shows a sequencer circuit with possible applications in many systems, and [Figure 15](#) shows the output waveforms.



NOTE A: S closes momentarily at $t = 0$.

Figure 14. Sequential Timer Circuit

8.2.4.1. Design Requirements

The sequential timer application chains together multiple mono-stable timers. The joining components are the 33- kΩ resistors and 0.001-μF capacitors. The output high to low edge passes a 10-μs start pulse to the next monostable.

8.2.4.2. Detailed Design Procedure

The timing resistors and capacitors can be chosen using this formula. $t_w = 1.1 \times R \times C$.

8.2.4.3. Application Curves

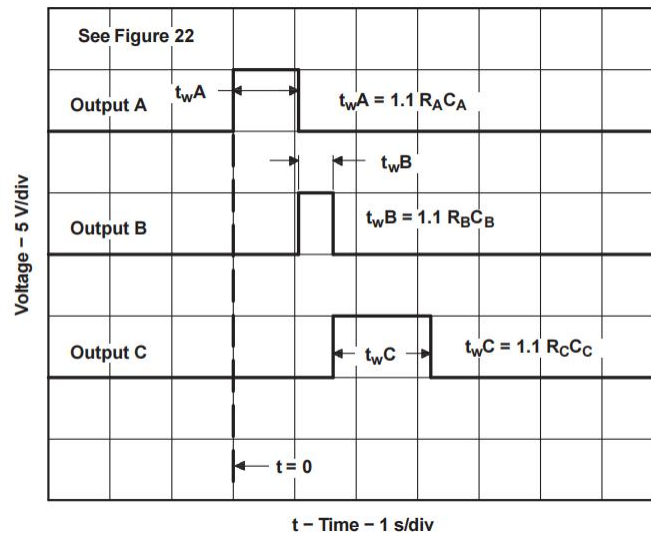

Figure 15. Sequential Timer Waveforms

9. Power Supply Recommendations

The devices are designed to operate from an input voltage supply range between 4.5 V and 16 V.. A bypass capacitor is highly recommended from V_{CC} to ground pin; ceramic 0.1 μF capacitor is sufficient.

10. ORDERING INFORMATION

Ordering Information

Part Number	Device Making	Package type	Body size (mm)	Temperate (°C)	MSL	Transpo Rt	Package Quantit
XLE555DR	XLE555D	SOP-8	4.90*3.90	-40 to +85	MSL3	T&R	2500
XLA555DR	XLA555D	SOP-8	4.90*3.90	-40 to +85	MSL3	T&R	2500

11. DIMENSIONAL DRAWINGS

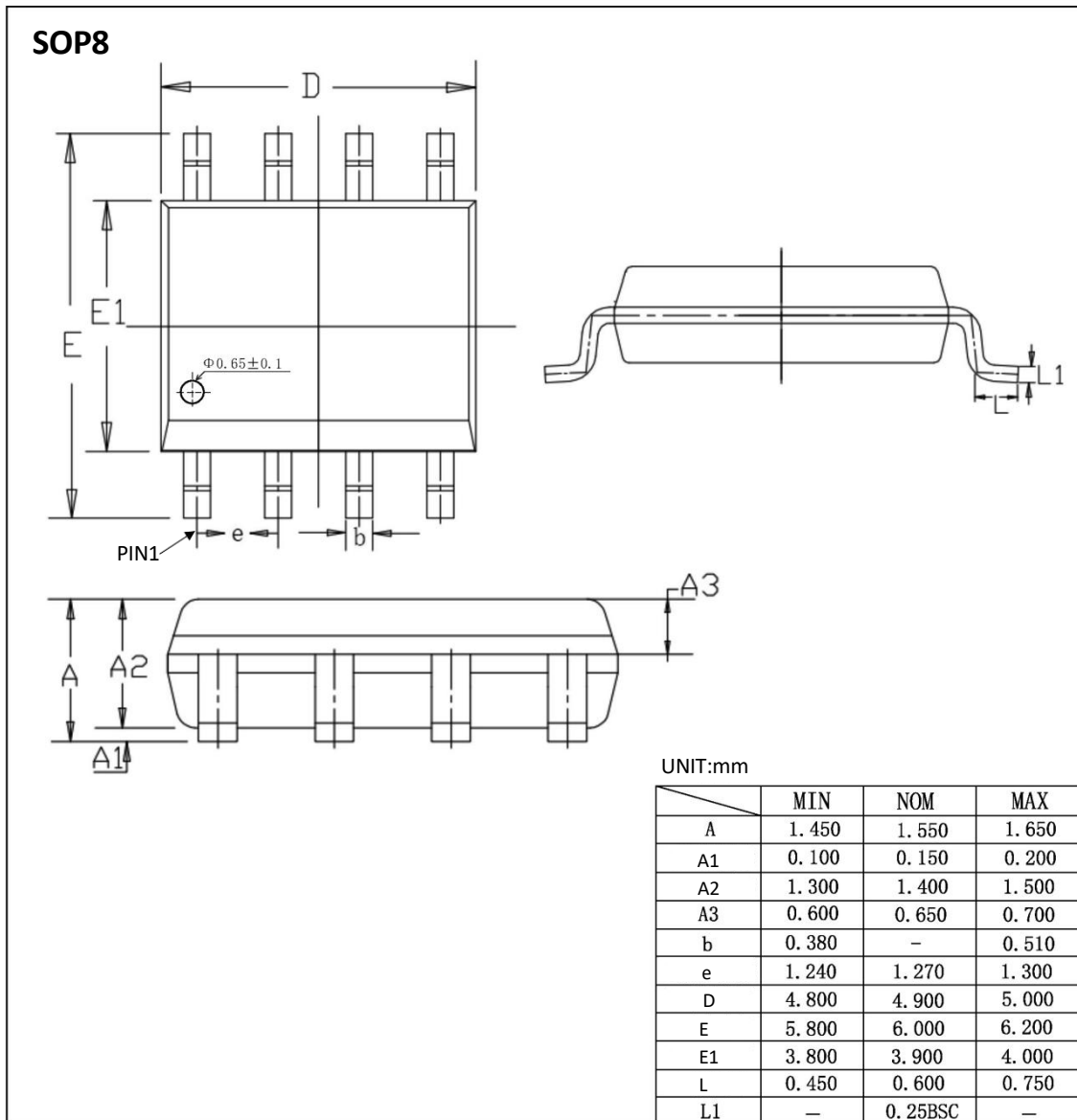

[if you need help contact us. Xinluda reserves the right to change the above information without prior notice]