

1. General Description

The 74LVC32A is a quad 2-input OR gate. Inputs can be driven from either 3.3 V or 5 V devices. This feature allows the use of these devices as translators in mixed 3.3 V and 5 V environments.

Schmitt-trigger action at all inputs makes the circuit tolerant of slower input rise and fall times.

This device is fully specified for partial power down applications using I_{OFF} . The I_{OFF} circuitry disables the output, preventing the potentially damaging backflow current through the device when it is powered down.

2. Features and Benefits

- Wide supply voltage range from 1.2 V to 5.5 V
- Overvoltage tolerant inputs to 5.5 V
- CMOS low power dissipation
- I_{OFF} circuitry provides partial Power-down mode operation
- Latch-up performance exceeds 250 mA
- Direct interface with TTL levels
- Complies with JEDEC standard:
 - JESD8-7A (1.65 V to 1.95 V)
 - JESD8-5A (2.3 V to 2.7 V)
 - JESD8-C (2.7 V to 3.6 V)
 - JESD36 (4.5 V to 5.5 V)
- ESD protection:
 - HBM ANSI/ESDA/JEDEC JS-001 Class 3A exceeds 6000 V
 - CDM ANSI/ESDA/JEDEC JS-002 Class C3 exceeds 2000 V
- Multiple package options

3. Ordering Information

Table 1. Ordering information

Type number	Package		
	Name	Description	Quantity
74LVC32AD	SOP-14L	plastic small outline package; 14 leads; body width 3.9 mm	2500
74LVC32APW	TSSOP-14L	plastic thin shrink small outline package; 14 leads; body width 4.4 mm	2500

4. Function Diagram

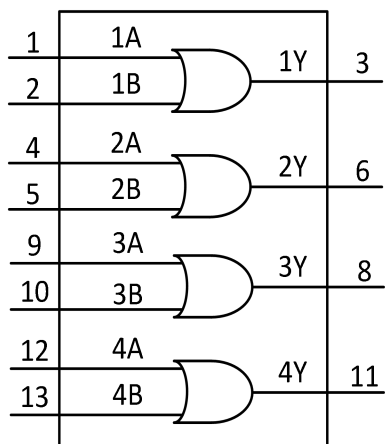
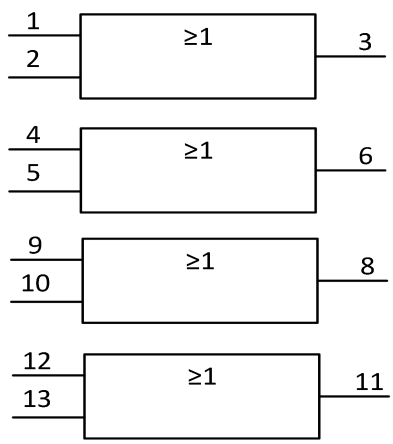
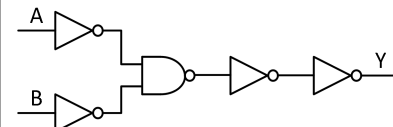
 <p style="text-align: center;">Fig. 1. Logic symbol</p>	 <p style="text-align: center;">Fig. 2. IEC logic symbol</p>	 <p style="text-align: center;">Fig. 3. Logic diagram(one gate)</p>
--	--	--

5. Pinning Information

5.1. Pinning

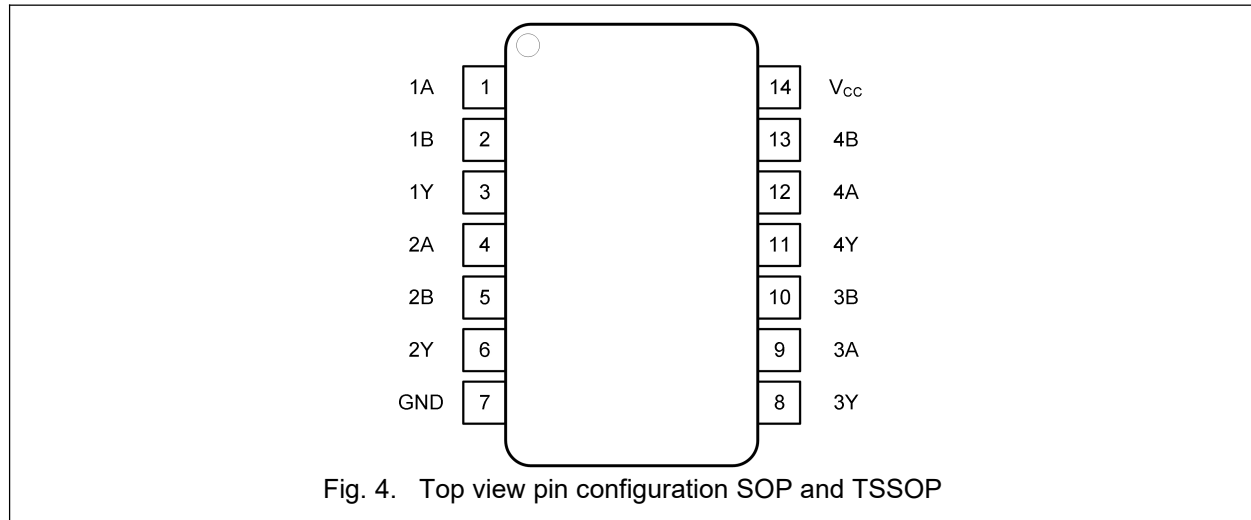

5.2. Pin description

Table 2. Pin description

Symbol	Pin	Description
1A, 2A, 3A, 4A	1, 4, 9, 12	Data input
1B, 2B, 3B, 4B	2, 5, 10, 13	Data input
1Y, 2Y, 3Y, 4Y	3, 6, 8, 11	Data output
GND	7	Ground (0V)
V _{CC}	14	Supply voltage

6. Functional Description

Table 3. Function table

H = HIGH voltage level; L = LOW voltage level; X = don't care.

Input		Output
nA	nB	nY
L	L	L
X	H	H
H	X	H

7. Absolute Maximum Ratings

Stresses exceeding the absolute maximum ratings may damage the device. The device may not function or be operable above the recommended operating conditions and stressing the parts to these levels is not recommended. In addition, extended exposure to stresses above the recommended operating conditions may affect device reliability. The absolute maximum ratings are stress ratings only.

Table 4. Absolute Maximum Ratings

In accordance with the Absolute Maximum Rating System (IEC 60134). Voltages are referenced to GND.

Symbol	Parameter	Conditions	Min	Max	Unit
V_{CC}	supply voltage		-0.5	6.5	V
I_{IK}	input clamping current	$V_I < 0$ V	-50		mA
V_I	input voltage	[1]	-0.5	6.5	V
I_{OK}	output clamping current	$V_O > V_{CC}$ or $V_O < 0$ V		± 50	mA
V_O	output voltage	Active mode [1]	-0.5	$V_{CC} + 0.5$	V
		Power-down mode; $V_{CC} = 0$ V [1]	-0.5	6.5	V
I_O	output current	$V_O = 0$ V to V_{CC}		± 50	mA
I_{CC}	supply current			100	mA
I_{GND}	ground current		-100		mA
P_{tot}	total power dissipation	$T_{amb} = -40$ °C to $+125$ °C		500	mW
T_{stg}	storage temperature		-65	150	°C

[1] The input and output voltage ratings may be exceeded if the input and output current ratings are observed.

8. Recommended Operating Conditions

The Recommended Operating Conditions table defines the conditions for actual device operation. Recommended operating conditions are specified to ensure optimal performance to the datasheet specifications. EnergyMath does not recommend exceeding them or designing to Absolute Maximum Ratings.

Table 5. Recommended Operating Conditions

Symbol	Parameter	Conditions	Min	Max	Unit
V_{CC}	supply voltage		1.65	5.5	V
		functional	1.2		V
V_I	input voltage		0	5.5	V
V_O	output voltage	Active mode	0	V_{CC}	V
		Power-down mode; $V_{CC} = 0$ V	0	5.5	V
T_{amb}	ambient temperature		-40	125	°C
$\Delta t/\Delta V$	Input transition rise and fall	$V_{CC} = 1.65$ V to 2.7 V	0	20	ns/V

	rate	$V_{CC} = 2.7\text{ V to }5.5\text{ V}$	0	10	ns/V
--	------	---	---	----	------

9. Static Characteristics

Table 6. Static characteristics

At recommended operating conditions. Voltages are referenced to GND (ground = 0 V).

Symbol	Parameter	Conditions	-40 °C to +85 °C			-40 °C to +125 °C		Unit
			Min	Typ[1]	Max	Min	Max	
V_{IH}	HIGH-level input voltage	$V_{CC} = 1.2\text{ V}$	1.08			1.08		V
		$V_{CC} = 1.65\text{ V to }1.95\text{ V}$	$0.65V_{CC}$			$0.65V_{CC}$		V
		$V_{CC} = 2.3\text{ V to }2.7\text{ V}$	1.7			1.7		V
		$V_{CC} = 2.7\text{ V to }3.6\text{ V}$	2.0			2.0		V
		$V_{CC} = 4.5\text{ V to }5.5\text{ V}$	$0.7V_{CC}$			$0.7V_{CC}$		V
V_{IL}	LOW-level input voltage	$V_{CC} = 1.2\text{ V}$			0.12		0.12	V
		$V_{CC} = 1.65\text{ V to }1.95\text{ V}$			$0.35V_{CC}$		$0.35V_{CC}$	V
		$V_{CC} = 2.3\text{ V to }2.7\text{ V}$			0.7		0.7	V
		$V_{CC} = 2.7\text{ V to }3.6\text{ V}$			0.8		0.8	V
		$V_{CC} = 4.5\text{ V to }5.5\text{ V}$			$0.3V_{CC}$		$0.3V_{CC}$	V
V_{OH}	HIGH-level output voltage	$V_I = V_{IH}\text{ or }V_{IL}$						
		$I_O = -100\mu\text{A}; V_{CC} = 1.65\text{ V to }5.5\text{ V}$	$V_{CC} - 0.1$			$V_{CC} - 0.1$		V
		$I_O = -4\text{ mA}; V_{CC} = 1.65\text{ V}$	1.2			1.05		V
		$I_O = -8\text{ mA}; V_{CC} = 2.3\text{ V}$	1.9			1.7		V
		$I_O = -12\text{ mA}; V_{CC} = 2.7\text{ V}$	2.2			2.05		V
		$I_O = -24\text{ mA}; V_{CC} = 3.0\text{ V}$	2.4			2.25		V
		$I_O = -32\text{ mA}; V_{CC} = 4.5\text{ V}$	3.8			3.5		V
V_{OL}	LOW-level output voltage	$V_I = V_{IH}\text{ or }V_{IL}$						
		$I_O = 100\mu\text{A}; V_{CC} = 1.65\text{ V to }5.5\text{ V}$			0.10		0.10	V
		$I_O = 4\text{ mA}; V_{CC} = 1.65\text{ V}$			0.45		0.65	V
		$I_O = 8\text{ mA}; V_{CC} = 2.3\text{ V}$			0.30		0.45	V
		$I_O = 12\text{ mA}; V_{CC} = 2.7\text{ V}$			0.40		0.60	V
		$I_O = 24\text{ mA}; V_{CC} = 3.0\text{ V}$			0.55		0.80	V
		$I_O = 32\text{ mA}; V_{CC} = 4.5\text{ V}$			0.55		0.80	V
I_I	Input leakage	$V_I = 5.5\text{ V or GND}; V_{CC} = 0\text{ V to }5.5\text{ V}$		± 0.1	± 5		± 20	μA

74LVC32A

Quad 2-input OR gate

	current							
--	---------	--	--	--	--	--	--	--

Symbol	Parameter	Conditions	-40 °C to +85 °C			-40 °C to +125 °C		Unit
			Min	Typ[1]	Max	Min	Max	
I_{OFF}	power-off leakage current	$V_{CC} = 0V ; V_I \text{ or } V_O = 5.5 V$		± 0.1	± 10		± 20	μA
I_{CC}	supply current	$V_I = 5.5V \text{ or } GND ; I_O = 0A ; V_{CC} = 1.65V \text{ to } 5.5V$		0.01	10		40	μA
ΔI_{CC}	additional supply current	per input pin ; $V_{CC} = 2.3V \text{ to } 5.5V ; V_I = V_{CC} - 0.6V ; I_O = 0A$		0.2	500		5000	μA
C_i	input capacitance	$V_{CC} = 3.3V ; V_I = GND \text{ to } V_{CC}$		4				pF

[1]All typical values are measured at $V_{CC} = 3.3V$ and $T_{amb} = 25^\circ C$.

10. Dynamic Characteristics

Table 7. Dynamic characteristics

Voltages are referenced to GND (ground = 0 V); for test circuit see Fig. 7.

Symbol	Parameter	Conditions	-40 °C to +85 °C			-40 °C to +125 °C		Unit
			Min	Typ[1]	Max	Min	Max	
t_{pd}	propagation delay	nA,nB to nY; see Fig. 5 [2]						
		$V_{CC} = 1.2 \text{ V}$		36				ns
		$V_{CC} = 1.65 \text{ V to } 1.95 \text{ V}$	3.4	7.9	22	3.4	22.5	ns
		$V_{CC} = 2.3 \text{ V to } 2.7 \text{ V}$	2.7	4.4	10.5	2.7	11	ns
		$V_{CC} = 3.0 \text{ V to } 3.6 \text{ V}$	2	3.4	7.5	2	8	ns
		$V_{CC} = 4.5 \text{ V to } 5.5 \text{ V}$	1.5	2.6	5	1.5	5.5	ns
$t_{sk(o)}$	output skew time	$V_{CC} = 3.0 \text{ V to } 3.6 \text{ V}$ [3]			1.0		1.5	ns
C_{PD}	power dissipation capacitance	per gate ; $V_I = \text{GND to } V_{CC}$ [4]						
		$V_{CC} = 1.65 \text{ V to } 1.95 \text{ V}$		12				pF
		$V_{CC} = 2.3 \text{ V to } 2.7 \text{ V}$		13				pF
		$V_{CC} = 3.0 \text{ V to } 3.6 \text{ V}$		14				pF
		$V_{CC} = 4.5 \text{ V to } 5.5 \text{ V}$		16				pF

[1] Typical values are measured at $T_{amb} = 25 \text{ °C}$ and $V_{CC} = 1.2 \text{ V}, 1.8 \text{ V}, 2.5 \text{ V}, 3.3 \text{ V}$ and 5.0 V respectively.

[2] t_{pd} is the same as t_{PLH} and t_{PHL} .

[3] Skew between any two outputs of the same package switching in the same direction. This parameter is guaranteed by design.

[4] C_{PD} is used to determine the dynamic power dissipation (P_D in μW).

$P_D = C_{PD} \times V_{CC}^2 \times f_i \times N + \sum(C_L \times V_{CC}^2 \times f_o)$ where:

f_i = input frequency in MHz;

f_o = output frequency in MHz;

C_L = output load capacitance in pF;

V_{CC} = supply voltage in V;

N = number of inputs switching;

$\sum(C_L \times V_{CC}^2 \times f_o)$ = sum of outputs.

10.1. Waveforms and test circuit

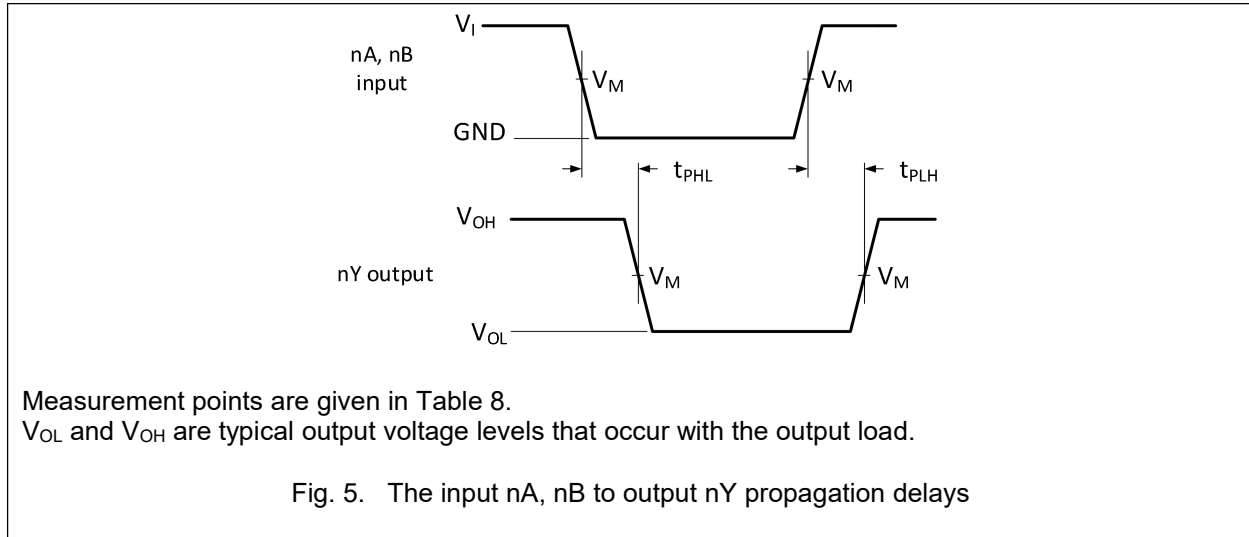
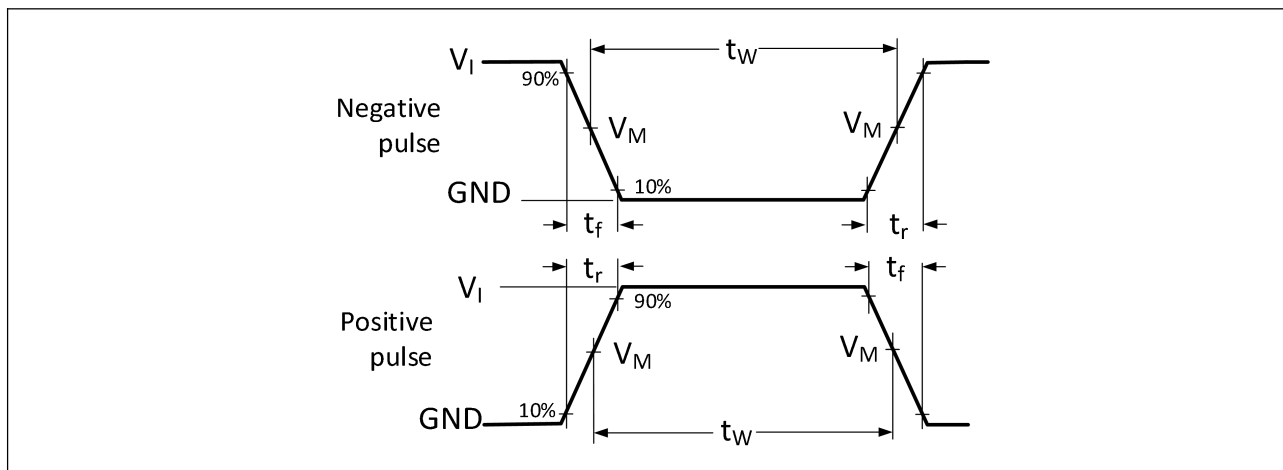
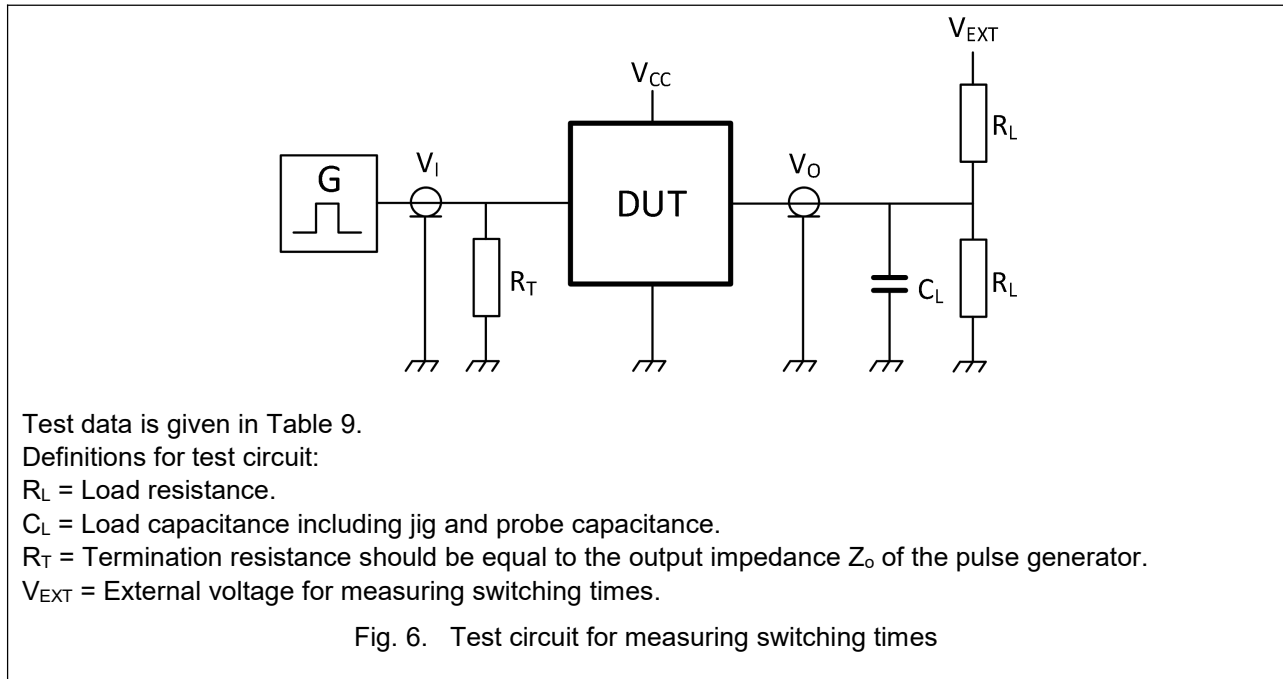

Table 8. Measurement points

Supply voltage	Input	Output
V_{CC}	V_M	V_M
1.2 V	$0.5V_{CC}$	$0.5V_{CC}$
1.65 V to 1.95 V	$0.5V_{CC}$	$0.5V_{CC}$
2.3 V to 2.7 V	$0.5V_{CC}$	$0.5V_{CC}$
3.0 V to 3.6 V	1.5 V	1.5 V
4.5 V to 5.5 V	$0.5V_{CC}$	$0.5V_{CC}$

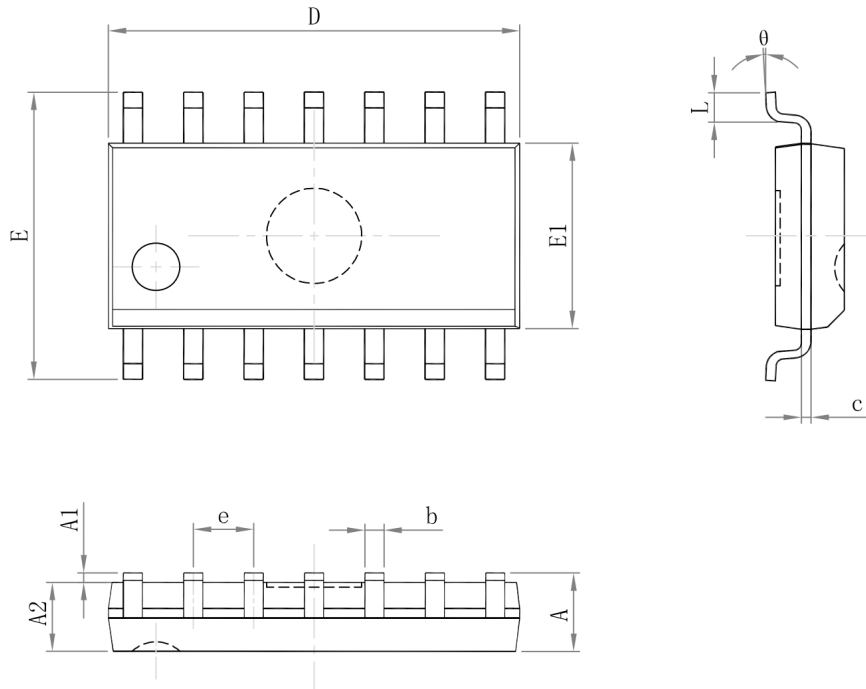



Table 9. Test data

Supply voltage	Input		Load		V_{EXT}
V_{CC}	V_I	$t_r = t_f$	C_L	R_L	t_{PLH}, t_{PHL}
1.2 V	V_{CC}	≤ 2.0 ns	15 pF	500 Ω	open
1.65 V to 1.95 V	V_{CC}	≤ 2.0 ns	15 pF	500 Ω	open
2.3 V to 2.7 V	V_{CC}	≤ 2.0 ns	15 pF	500 Ω	open
3.0 V to 3.6 V	3 V	≤ 2.0 ns	15 pF	500 Ω	open
4.5 V to 5.5 V	V_{CC}	≤ 2.0 ns	15 pF	500 Ω	open

11. Package Outline

SOP-14L



Symbol	Dimensions In Millimeters		Dimensions In Inches	
	Min	Max	Min	Max
A	—	1.750	—	0.069
A1	0.100	0.250	0.004	0.010
A2	1.250	—	0.049	—
b	0.310	0.510	0.012	0.020
c	0.100	0.250	0.004	0.010
D	8.450	8.850	0.333	0.348
E	5.800	6.200	0.228	0.244
E1	3.800	4.000	0.150	0.157
e	1.270(BSC)		0.050(BSC)	
L	0.400	1.270	0.016	0.050
theta	0°	8°	0°	8°

TSSOP-14L

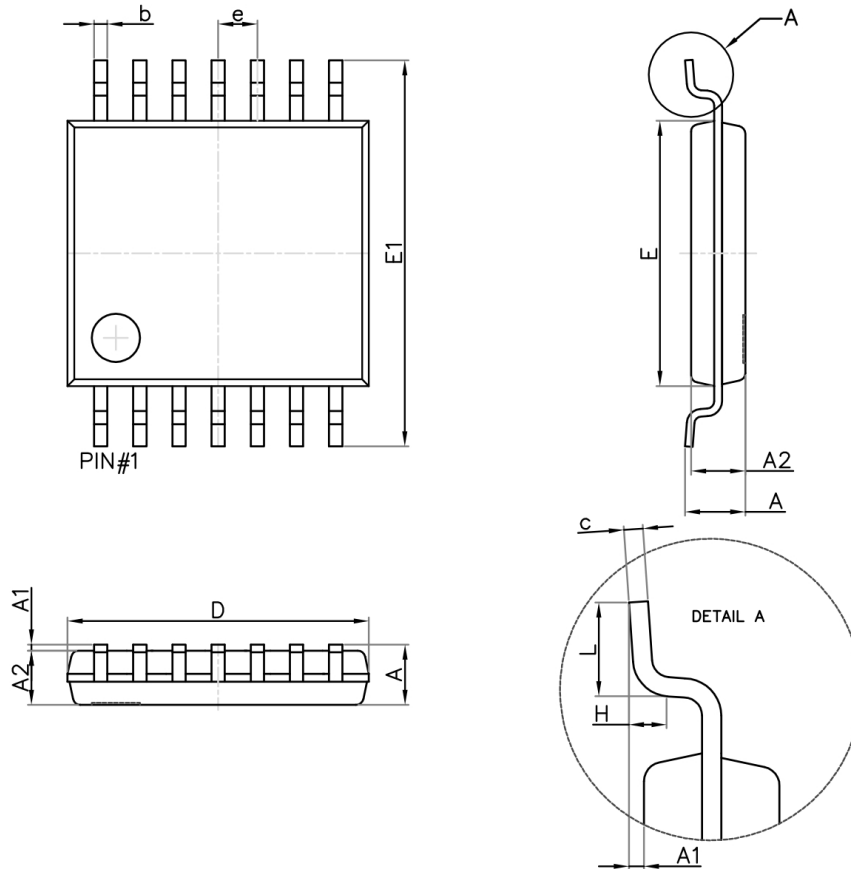

Symbol	Dimensions In Millimeters		Dimensions In Inches	
	Min.	Max.	Min.	Max.
D	4.900	5.100	0.193	0.201
E	4.300	4.500	0.169	0.177
b	0.190	0.300	0.007	0.012
c	0.090	0.200	0.004	0.008
E1	6.250	6.550	0.246	0.258
A	—	1.200	—	0.047
A2	0.800	1.000	0.031	0.039
A1	0.050	0.150	0.002	0.006
e	0.65 (BSC)		0.026 (BSC)	
L	0.500	0.700	0.020	0.028
H	0.25(TYP)		0.01(TYP)	
θ	1°	7°	1°	7°

12. Abbreviations

Table 10. Abbreviations

Acronym	Description
CMOS	Complementary Metal-Oxide Semiconductor
DUT	Device Under Test
ESD	ElectroStatic Discharge
HBM	Human Body Model
CDM	Charged Device Model
TTL	Transistor-Transistor Logic

13. Revision History

Table 11. Revision history

Document ID	Release Date	Data sheet status	Change notice	Supersedes
74LVC32A Rev. 1.0	Aug 08, 2024	Product datasheet		