

REV	LTR	DESCRIPTION	DATE	APPROVED
A0		依新料号编码原则发行图面	2024. 12. 26	

A
B
C
D
E
F

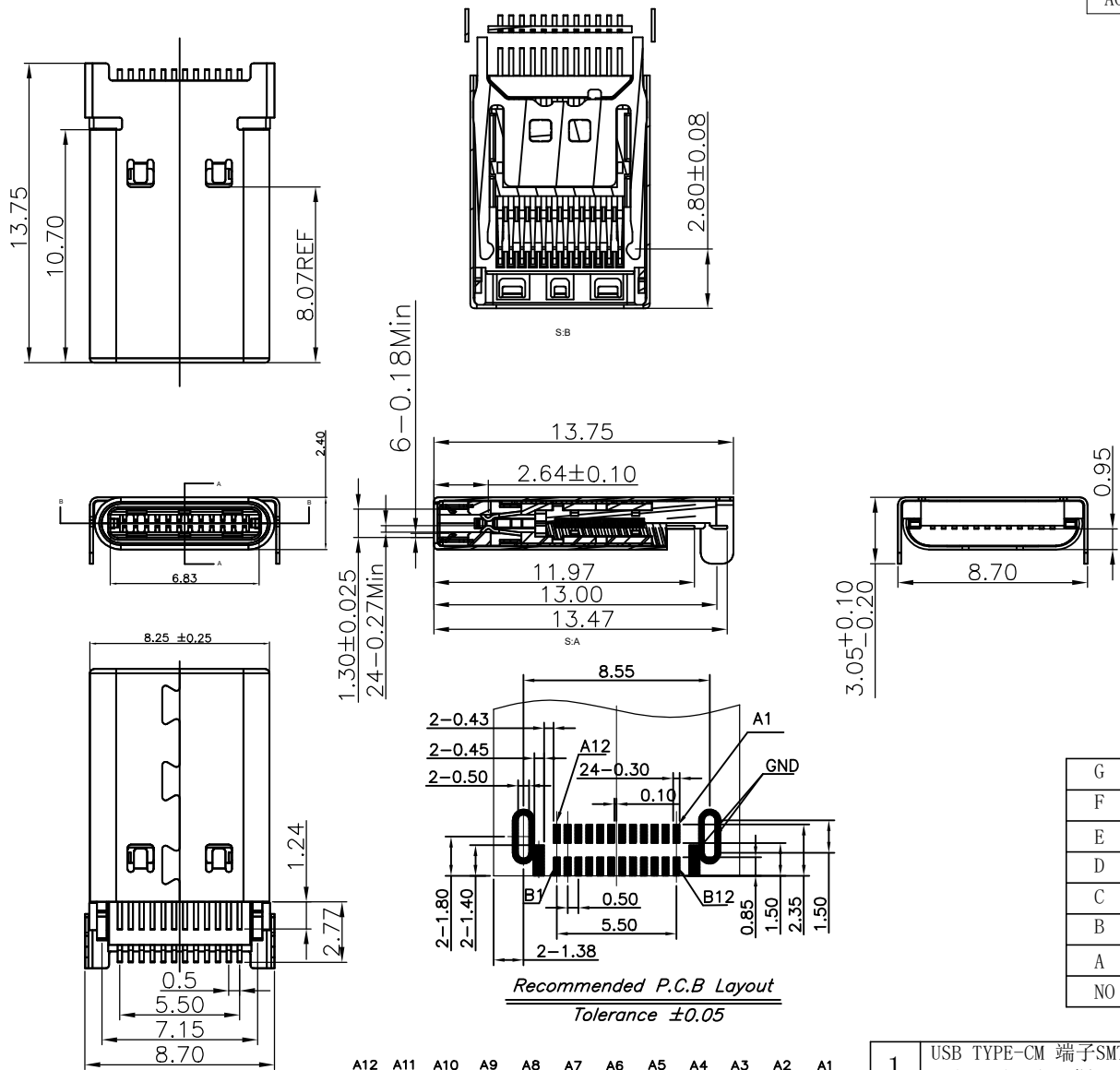

1. Material:
 Contacts: Copper alloy T=0.15
 Insulator: HIGH TEMPERATURE PLASTIC UL 94V-0,
 Shell: STEEL T=0.15
 MID Plate: Stainless Steel
 EMI Plate: Stainless Steel

2. Electrical:
 Current-max[amps]: 5A Max For Vbus/GND PIN;
 0.9A Max For Other PIN.
 Withstanding Voltage: 100V AC R.M.S
 Contact Resistance [ohms]: 40mΩ Max. For
 Initial 10mΩ. Change Afier
 Test. Measure AT 20mV, 100mA
 Insulation Resistance [ohms]: 100 mΩ min.

3. MECHANICAL CHARACTERISTICS:
 Mating force: 5~20N
 Unmated Force: 6~20N After test.
 Durability: 10000 cycles min.

4. Plating:
 Contacts: SEE TABLE Au plated on contact area,
 Fog SN plating 80~100u"Min on solder area
 Nickel Under plating 20u"Min over all
 Gnd pin: Plating 30u"min Nickel under overall
 on solder SN 80u"Min
 Shell : plating 50~100u"Nickel over

5. Environmental
 Temperature Range: -55° C~+85° C

G	EMI	2	SUS301	---
F	CONTACT	12	C7025	Au:1U"
E	TOP COVER	1	LCP+30%GF, UL 94V-0	BLACK
D	BOTTOM COVER	1	LCP+30%GF, UL 94V-0	BLACK
C	GND PIN	1	SUS301	30U" min NI on SN Plating
B	CONTACT	12	C7025	Au:1U"
A	SHELL	1	SUS301	50~100u"NICKEL Plating
NO	DESCRIPTION	QTY	MATERIAL	PLATING & COLOR

1	USB TYPE-CM 端子SMT+SMT 不锈钢DIP脚外壳 黑色料雾锡高导电铜Gold Flash成品 (卷装)		不锈钢壳镍;黑胶;高导电C7025端子G/F U"
ITEM	Part Name	Part No.	Marker

TABLE:

品名 TITLE	TYPE CM 24P双贴 沉板0.95 后两脚插 13.75L 5A 3MD SUS301编带	设计 DESIGNED BY: 刘 静	比例 SCALE	1:1	■ Rohs ■ HF	TOLERANCE (UNLESS SPECIFIED)	
料号 PART NO:	TYPE24-N1B1-2137-Z	审核 CHECKED BY: 张 工	张数 SHEET	1/1	☉	.0±0.30	0.° ±10°
图号 DWG NO:		批准 APPROVE BY: 孟 生	版本 VER.	A0	单位 UNITS:mm	.00±0.20	0.° ±8°
						.000±0.10	0.00° ±5°

东莞市高钺达电子科技有限公司
 惠州市高钺达光电科技有限公司

REV	LTR	DESCRIPTION	DATE	APPROVED
A0		依新料号编码原则发行图面	2024. 12. 26	

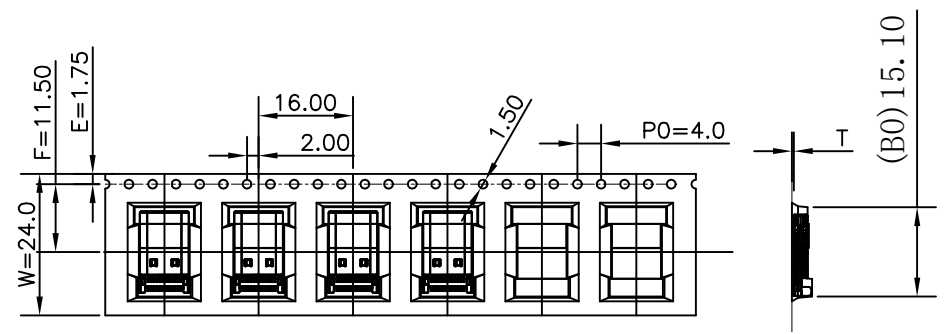

① 产品入载带示意图

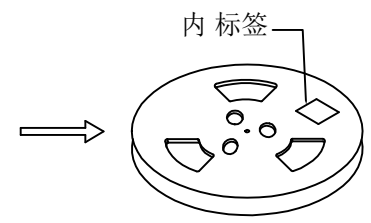

② 卷盘贴标签示意图

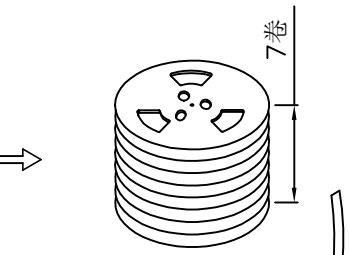

③ 7盘产品叠层示意图

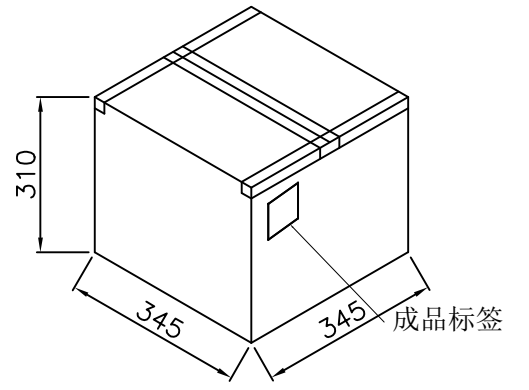

⑤ 外箱封箱示意图

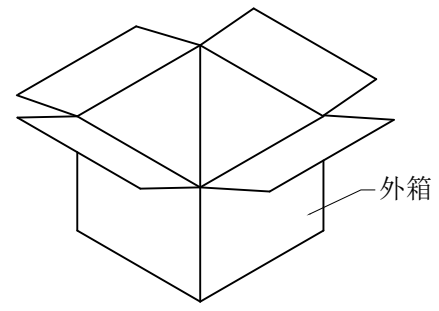

④ 产品入外箱示意图

- 包装说明:
- 将检验好的成品;对插口朝前放入载带;每卷装1000PCS产品;具体如图一所示
 - 将包装好的产品;每盘必需贴上内标签;具体如图二所示
 - 将贴好内标签的产品每7盘叠;具体如图三所示
 - 装好后并封好纸箱及贴好相关标签;具体如图五所示;
(产品包装的标签, 如客户有要求, 请按客户要求包装出货)
 - 载带前面留22PCS空格, 后面留22PCS空格
 - COVER与CARRY剥离力: 50-125g, 速度: 300mm/分钟左右, 剥离角度: 165° -180°

	REEL	CARTON
CONNECTOR (PCS)	1000	7000

品名 TITLE	TYPE CM 24P双贴 沉板0.95 后两脚插 13.75L 5A 3MD SUS301编带	设计 DESIGNED BY: 刘静	比例 SCALE 1:1	1:1	■ RoHS ■ HF	TOLERANCE (UNLESS SPECIFIED)
料号 PART NO:		审核 CHECKED BY: 张工	张数 SHEET 1/1			.0±0.30 0.° ±10° .00±0.20 .0° ±8° .000±0.10 .00° ±5°
图号 DWG NO:		批准 APPROVE BY: 孟生	版本 VER. A0		单位 UNITS:mm	

东莞市高钺达电子科技有限公司
惠州市高钺达光电科技有限公司