

WMM7035AT0

Top port analog silicon Microphone

[Http://www.willsemi.com](http://www.willsemi.com)

Descriptions

The WMM7035AT0 is a miniature, high performance, low power, top port silicon microphone. The WMM7035AT0 consists of an acoustic sensor, a low noise input buffer, and an output amplifier. These devices are suitable for portable electronic devices where excellent wideband audio performance and RF immunity are required applications.

The WMM7035AT0 is manufactured in a compact 3.50mm*2.65mm*1.00mm, 6-pin package.

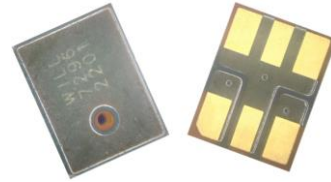

Product appearance

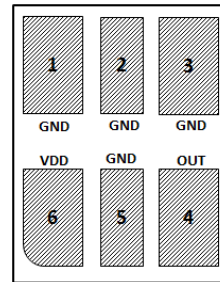

Pin configuration (Bottom view)

Features

- Matched Sensitivity
- Low current
- High SNR
- Small package
- MaxRF protection
- Ultra-Stable Performance
- Standard SMD Reflow
- Omnidirectional

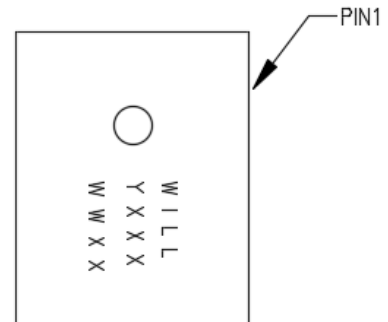

Marking (Top view)

Y = Year code
 WW = Week code
 X X X
 X X = Batch code
 WILL = Device Logo

Applications

- Cellphones
- Smart phones
- Laptop computers
- Smart speakers
- Digital still cameras
- Portable music recorders

Order information

Device	Package	Shipping
WMM7035AT0-6/TR	3.50*2.65*1.00	5000/Reel&Tape

Absolute maximum ratings

Parameter	Absolute Maximum Rating	Units
VDD to Ground	-0.5, +5.0	V
OUT to Ground	-0.3, VDD + 0.3	V
Input Current to Any Pin	±5	mA
Temperature Range	-40 to +100	°C

Stresses exceeding these “Absolute Maximum Ratings” may cause permanent damage to the device. These are stress ratings only. Functional operation at these or any other conditions beyond those indicated under “Acoustic & Electrical Specifications” is not implied. Exposure beyond those indicated under “Acoustic & Electrical Specifications” for extended periods may affect device reliability.

ACOUSTIC & ELECTRICAL SPECIFICATIONS

TEST CONDITIONS: 23 ±2°C, 55±20% R.H., V_{DD}(min) < V_{DD} < V_{DD}(max), no load, unless otherwise indicated

Parameter	Symbol	Conditions	Min	Typ	Max	Units
Supply Voltage	VDD		1.5	-	3.6	V
Supply Current	IDD		-	92	100	uA
Sensitivity	S	94dB SPL @1KHz	-39	-38	-37	dBv
Signal to Noise Ratio	SNR	94dB SPL @1KHz, A-weighted	-	65	-	dB(A)
Total Harmonic Distortion	THD	94dB SPL @1KHz, S=Typ, VDD=2.2V	-	0.15	0.5	%
Acoustic Overload Point	AOP	10%THD @1KHz, S=Typ, VDD=2.2V	-	130	-	dB SPL
Power Supply Rejection	PSR	100mVpp square wave @217Hz, A-weighted	-	-101	-	dBv
DC Output		VDD=2.2V	-	-	1.1	V
Output impedance	ZOUT	@1KH	-	-	300	Ω
Directivity			Omnidirectional			

Typical specifications are measured at VDD = 2.2V.

Frequency response curve

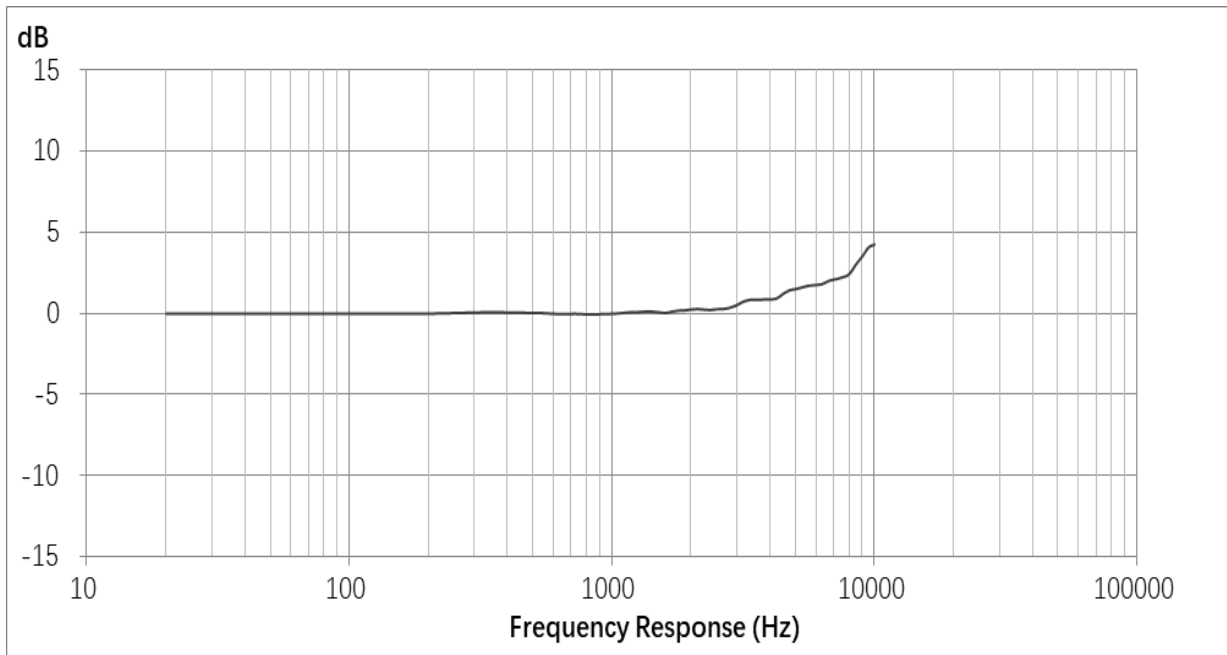

Application informations

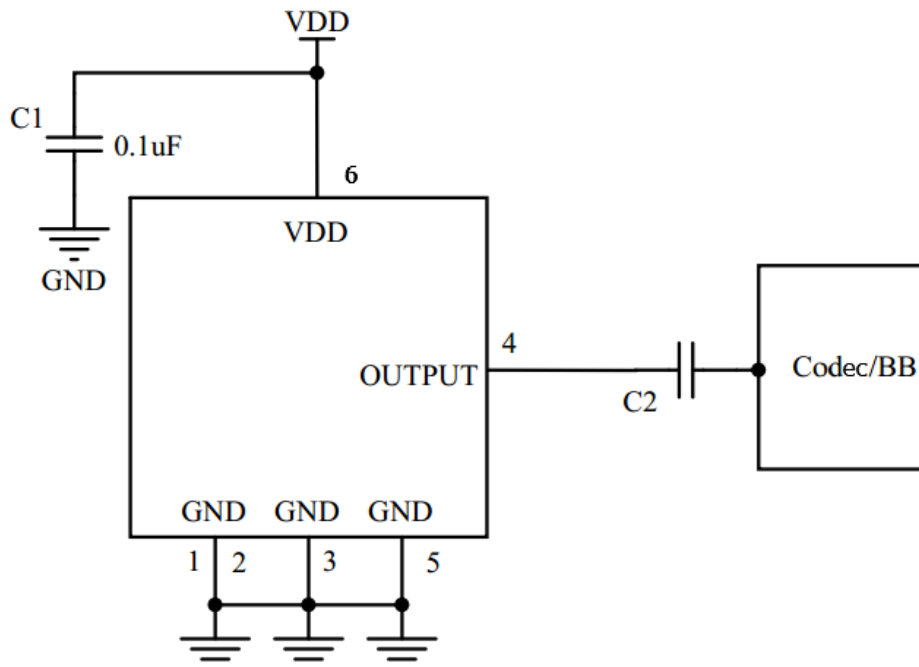

Note:

- All GND pins must be connected to ground.
- Capacitors near the microphone should not contain Class 2 dielectrics.

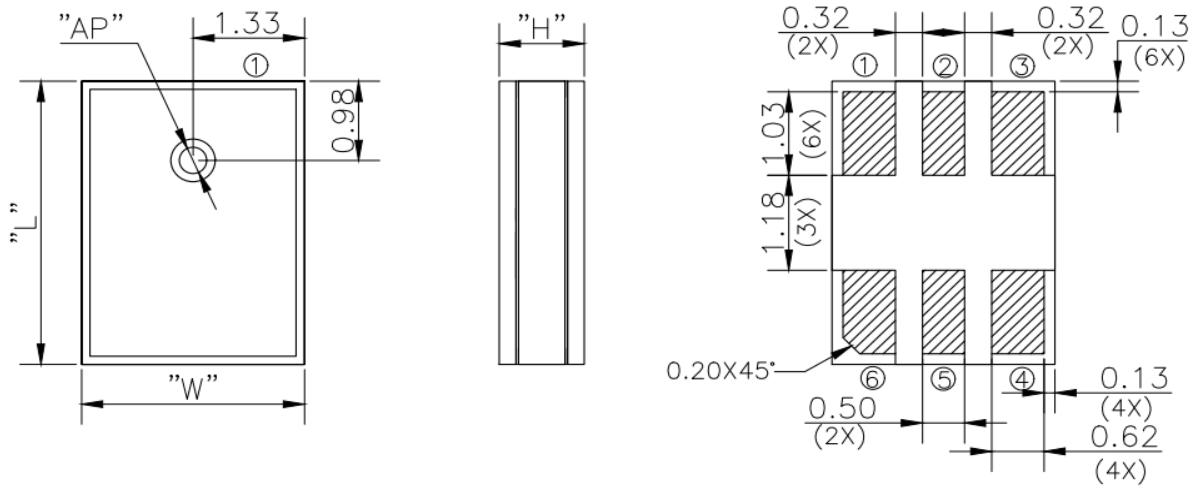
MECHANICAL SPECIFICATIONS

Item	Dimension	Tolerance
Length(L)	3.50	±0.10
Width(W)	2.65	±0.10
Height(H)	1.00	±0.10
Acoustic Port (AP)	Ø0.325	±0.05

Pin#	Pin Name	Description
1	GND	GND
2	GND	GND
3	GND	GND
4	OUTPUT	Output Signal
5	GND	GND
6	VDD	Power Supply

Notes:

- Dimensions are in millimeters unless otherwise specified.
- Tolerance is ±0.10mm unless otherwise specified.

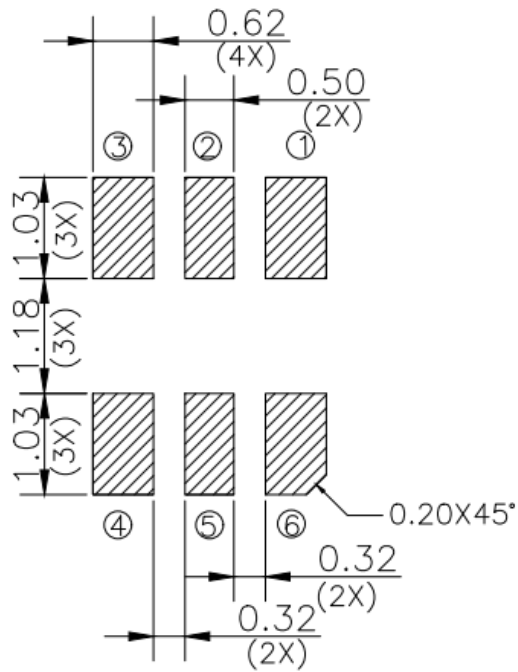
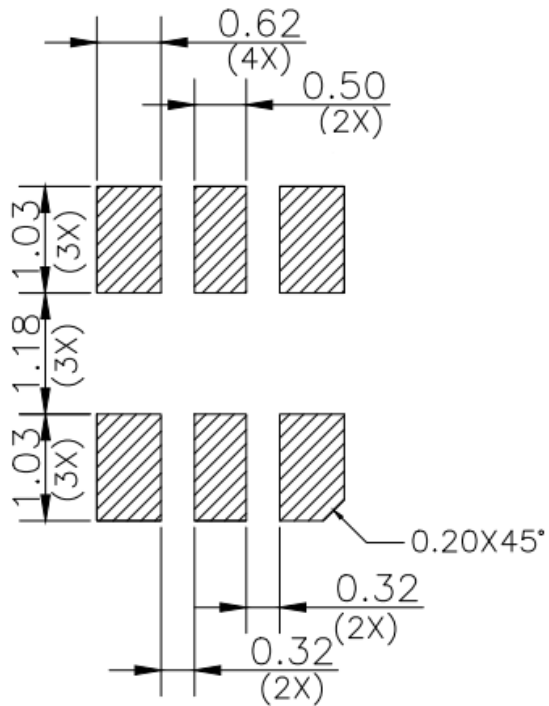
EXAMPLE AND PATTERN

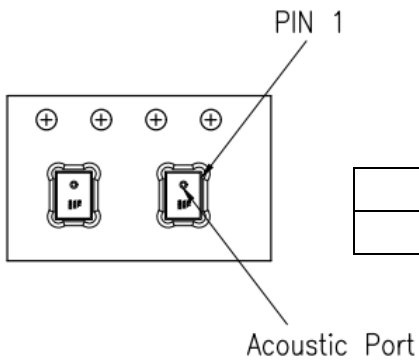
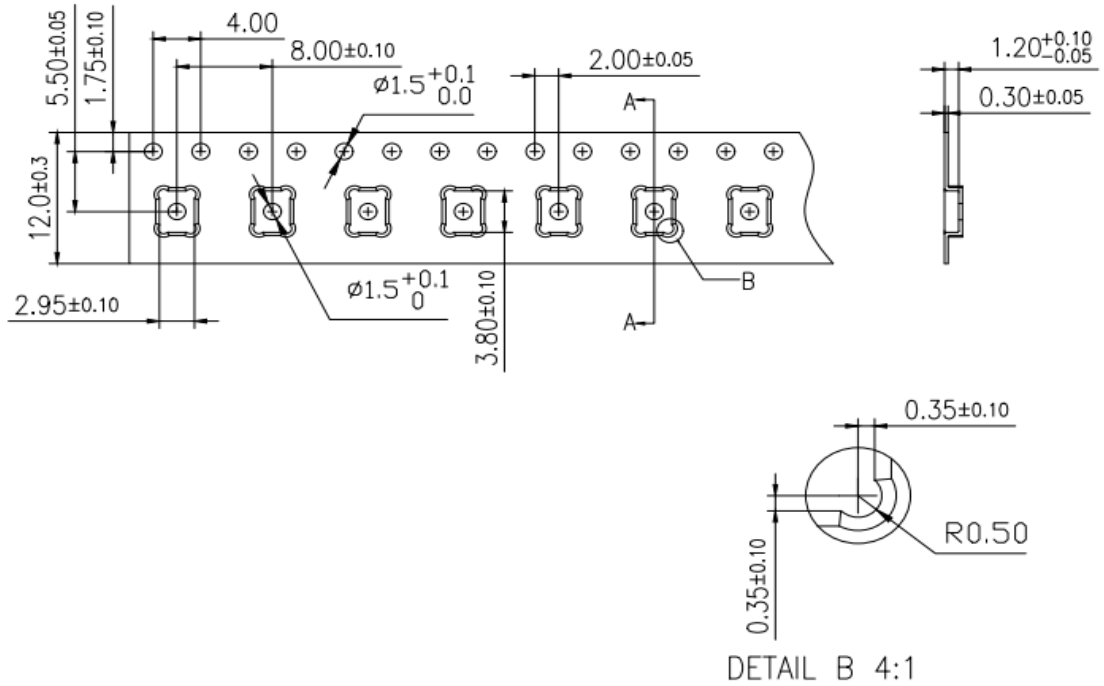
EXAMPLE SOLDER STENCIL PATTERN

PACKAGING & MARKING DETAIL

Model Number	Reel Diameter	Quantity Per Reel
WMM7035AT0	13"	5,000

Notes:

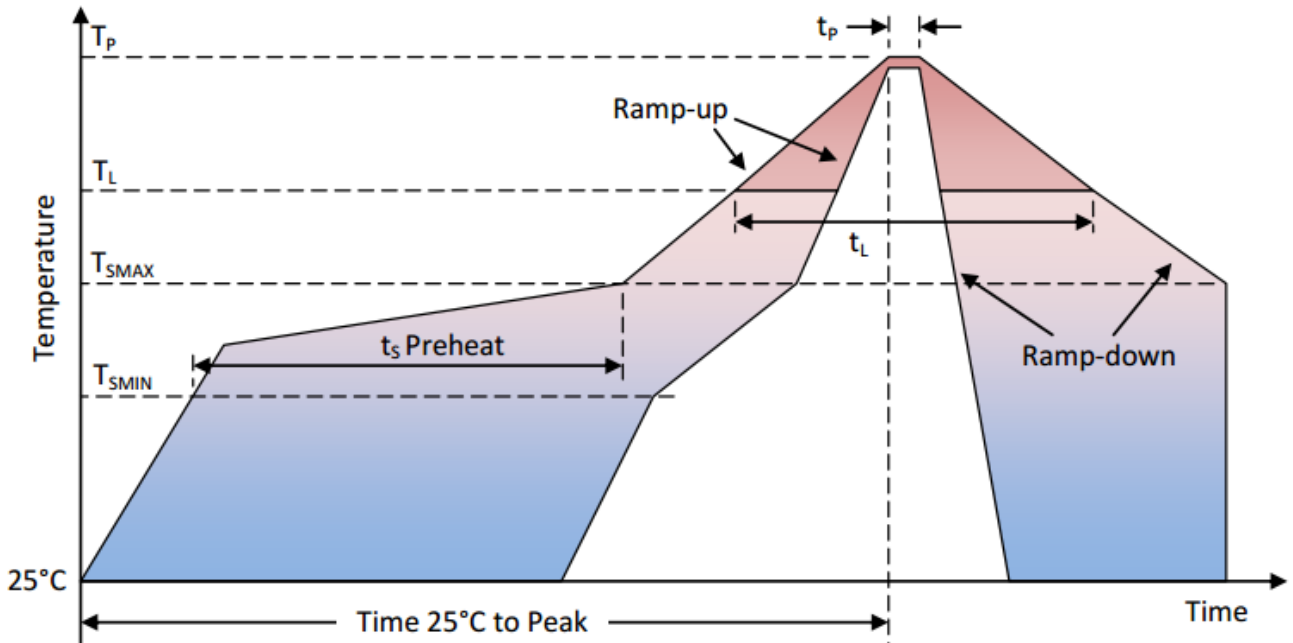
- Dimensions are in millimeters unless otherwise specified.
- Vacuum pickup only in the pick area indicated in Mechanical Specifications.
- Tape & reel per EIA-481.
- Labels applied directly to reel and external package.

REFERENCED REFLOW PROFILE

Profile Feature	Pb-Free
Average Ramp-up rate (T_{SMAX} to T_P)	3°C/second max.
Preheat <ul style="list-style-type: none"> • Temperature Min (T_{SMIN}) • Temperature Max (T_{SMAX}) • Time (T_{SMIN} to T_{SMAX}) (t_s) 	150°C 200°C 60-180 seconds
Time maintained above: <ul style="list-style-type: none"> • Temperature (T_L) • Time (t_L) 	217°C 60-150 seconds
Peak Temperature (T_P)	260°C
Time within 5°C of actual Peak Temperature (t_p)	20-40 seconds
Ramp-down rate (T_P to T_{SMAX})	6°C/second max
Time 25°C to Peak Temperature	8 minutes max

Note:

All temperatures refer to topside of the package, measured on the package body surface.

ADDITIONAL NOTES

(A) MSL (moisture sensitivity level) Class 1.

(B) Maximum of 3 reflow cycles is recommended.

(C) In order to minimize device damage:

- Do not board wash or clean after the reflow process.
- Do not brush board with or without solvents after the reflow process.
- Do not directly expose to ultrasonic processing, welding, or cleaning.
- Do not insert any object in port hole of device at any time.
- Do not apply over 30 psi of air pressure into the port hole.
- Do not pull a vacuum over port hole of the microphone.
- Do not apply a vacuum when repacking into sealed bags at a rate faster than 0.5 atm/sec.

RELIABILITY SPECIFICATIONS

Test	Description
Thermal Shock	100 cycles air-to-air thermal shock from -40°C to +125°C with 15 minute soaks.
High Temperature Storage	1000 hours at +105°C environment
Low Temperature Storage	1000 hours at -40°C environment
Temperature / Humidity	1000 hours at +85°C /85% R.H.
Vibration	4 cycles of 20 to 2,000 Hz sinusoidal sweep with 20g peak acceleration lasting 12 minutes in X, Y, and Z directions.
ESD-HBM	3 discharges of ±2 kV direct contact to I/O pins.
ESD-LID/GND	3 discharges of ±8 kV direct contact to lid while unit is grounded.
ESD-MM	3 discharges of ±200V direct contact to I/O pins.
Reflow	5 reflow cycles with peak temperature of +260°C
Mechanical Shock	3 pulses of 3,000g in the X, Y, and Z direction

Note:

After reliability tests are performed, the sensitivity of the microphones shall not deviate more than 3 dB from its initial value.