

## Description:

This N-Channel MOSFET uses advanced trench technology and design to provide excellent  $R_{DS(on)}$  with low gate charge.

It can be used in a wide variety of applications.

## Features:

- 1)  $V_{DS}=60V, I_D=15A, R_{DS(ON)}<40m\ \Omega @V_{GS}=10V$  (Typ:  $30m\ \Omega$ )
- 2) Low gate charge.
- 3) Green device available.
- 4) Advanced high cell density trench technology for ultra low  $R_{DS(ON)}$ .
- 5) Excellent package for good heat dissipation.
- 6) MSL3

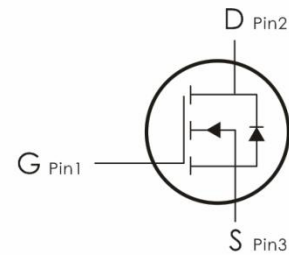
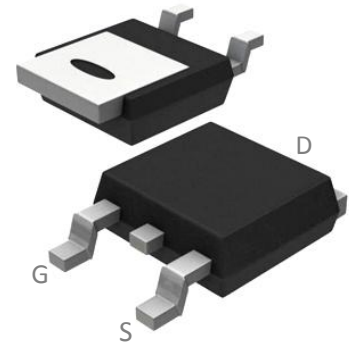

## Package Marking and Ordering Information:

Part NO.	Marking	Package	Packing
DE040NG-B	E040N-B	TO- 252	2500 pcs/Reel

## Absolute Maximum Ratings: ( $T_C=25^\circ C$ unless otherwise noted)

Symbol	Parameter	Ratings	Units
$V_{DS}$	Drain-Source Voltage	60	V
$V_{GS}$	Gate-Source Voltage	$\pm 20$	V
$I_D$	Continuous Drain Current <sup>1</sup>	15	A
	Continuous Drain Current- $T_C=100^\circ C$ <sup>1</sup>	10.5	
$I_{DM}$	Pulsed Drain Current <sup>2</sup>	60	
$P_D$	Power Dissipation	21	W
$E_{AS}$	Single pulse avalanche energy <sup>3</sup>	17.6	mJ
$T_J, T_{STG}$	Operating and Storage Junction Temperature Range	-55-+150	$^\circ C$

## Thermal Characteristics:

Symbol	Parameter	Max	Units
$R_{\theta JC}$	Thermal Resistance, Junction to Case	5.7	$^\circ C/W$

**Electrical Characteristics:** ( $T_C=25^\circ\text{C}$  unless otherwise noted)

Symbol	Parameter	Conditions	Min	Typ	Max	Units
<b>Off Characteristics</b>						
$BV_{DSS}$	Drain-Source Breakdown Voltage	$V_{GS}=0V, I_D=250\ \mu\text{A}$	60	---	---	V
$I_{DSS}$	Zero Gate Voltage Drain Current	$V_{GS}=0V, V_{DS}=60V$	---	---	1	$\mu\text{A}$
$I_{GSS}$	Gate-Source Leakage Current	$V_{GS}=\pm 20V, V_{DS}=0A$	---	---	$\pm 100$	nA
<b>On Characteristics</b>						
$V_{GS(th)}$	Gate-Source Threshold Voltage	$V_{GS}=V_{DS}, I_D=250\ \mu\text{A}$	1.2	1.67	2.5	V
$R_{DS(on)}$	Drain-Source On Resistance <sup>4</sup>	$V_{GS}=10V, I_D=10A$	---	30	40	$\text{m}\Omega$
		$V_{GS}=4.5V, I_D=5A$	---	36	47	$\text{m}\Omega$
<b>Dynamic Characteristics</b>						
$C_{iss}$	Input Capacitance	$V_{DS}=25V, V_{GS}=0V, f=1\text{MHz}$	---	650	---	pF
$C_{oss}$	Output Capacitance		---	44	--	
$C_{rss}$	Reverse Transfer Capacitance		---	39.9	---	
<b>Switching Characteristics</b>						
$t_{d(on)}$	Turn-On Delay Time	$V_{DS}=30V, I_D=10A,$ $R_{ENG}=2.7\ \Omega, V_{GS}=10V$	---	10.5	---	ns
$t_r$	Rise Time		---	73.5	---	ns
$t_{d(off)}$	Turn-Off Delay Time		---	16	---	ns
$t_f$	Fall Time		---	5	---	ns
$Q_g$	Total Gate Charge		$V_{GS}=10V, V_{DS}=30V,$	---	19	---
$Q_{gs}$	Gate-Source Charge	$I_D=10A$	---	4.2	---	nC
$Q_{gd}$	Gate-Drain "Miller" Charge		---	3.9	---	nC
<b>Drain-Source Diode Characteristics</b>						
$V_{SD}$	Diode Forward Voltage	$V_{GS}=0V, I_{SD}=15A$	---	---	1.2	V
$I_S$	Continuous Drain Current	$V_D=V_G=0V$	---	---	15	A
$I_{SM}$	Pulsed Drain Current		---	---	60	A
$T_{rr}$	Reverse Recovery Time	$I_F=10A, T_J=25^\circ\text{C}$	---	19	---	ns
$Q_{rr}$	Reverse Recovery Charge	$dI/dt=100A/\mu\text{s}$	---	21	---	nC

## Notes:

1. Computed continuous current assumes the condition of  $T_{j,Max}$  while the actual continuous current depends on the thermal & electro-mechanical application board design
2. Repetitive Rating: Pulse Width Limited by Maximum Junction Temperature
3. EAS condition :  $T_J=25^{\circ}C, V_{DD}=30V, V_G=10V, L=0.5mH$
4. Pulse Test: Pulse Width  $\leq 300\mu s$ , Duty Cycle  $\leq 0.5\%$

## Test Circuit

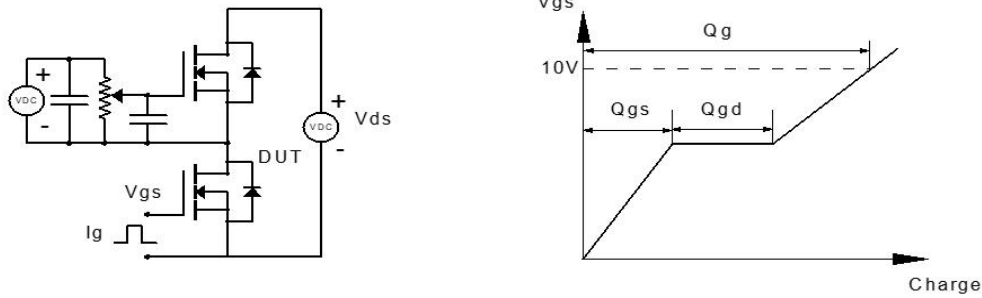

**Figure 1: Gate Charge Test Circuit & Waveform**

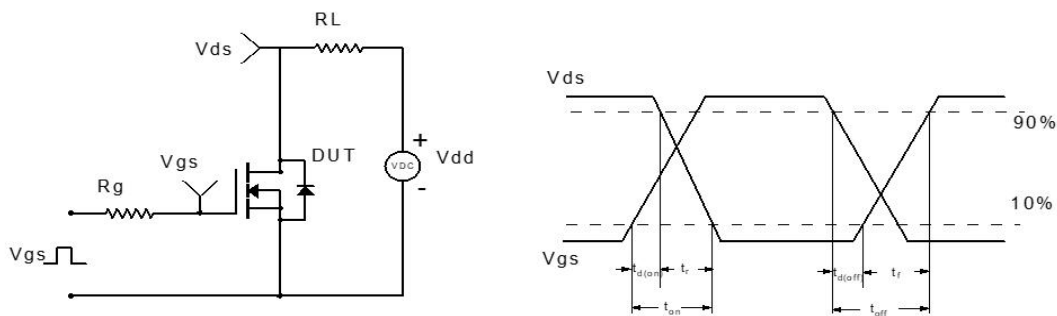

**Figure 2: Resistive Switching Test Circuit & Waveform**

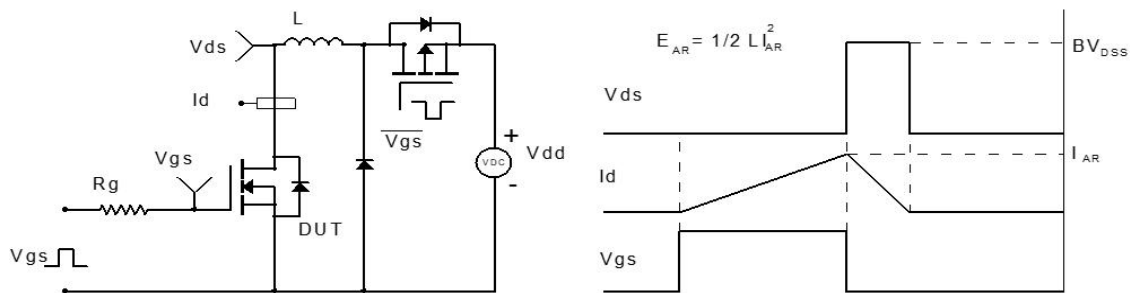

**Figure 3: Unclamped Inductive Switching Test Circuit & Waveform**

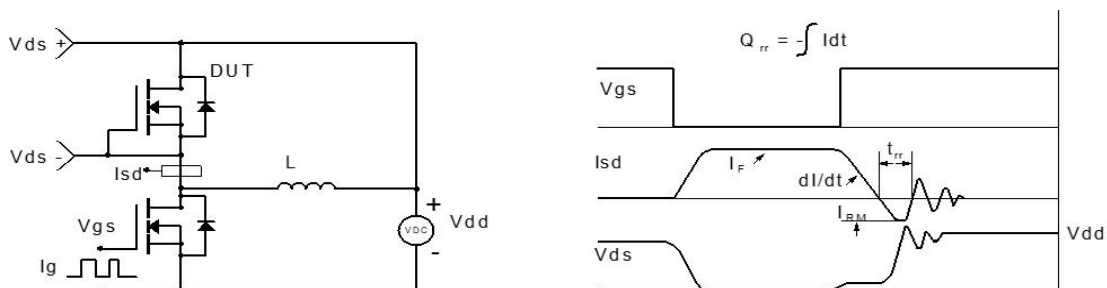

## TO-252 Package Information

### Package Outline Type-A

UNIT: mm

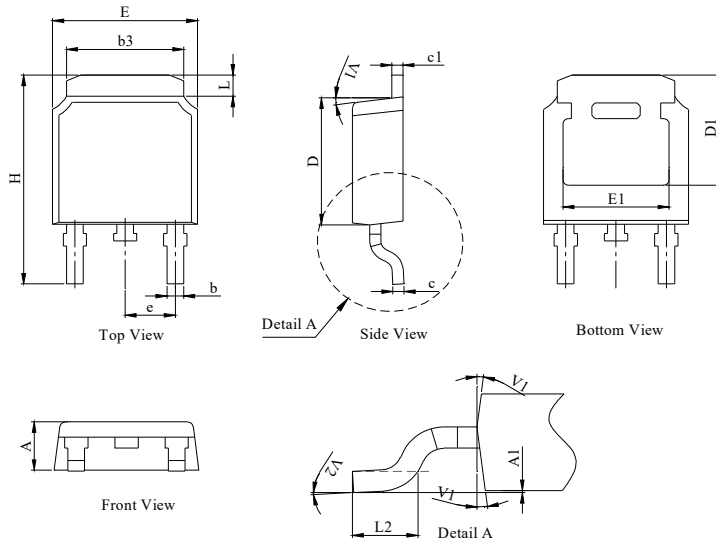

DIM.	MILLIMETER		
	MIN.	NOM.	MAX.
A	2.18	2.30	2.39
A1	0	--	0.13
b	0.64	0.76	0.89
c	0.40	0.50	0.61
c1	0.46	0.50	0.58
D	5.97	6.10	6.23
D1	5.05	--	--
E	6.35	6.60	6.73
E1	4.32	--	--
b3	5.21	5.38	5.55
e	2.29 BSC		
H	9.40	10.00	10.40
L	0.89	--	1.27
L2	1.40	--	1.78
V1	7° REF		
V2	0°	--	6°

### Package Outline Type-B

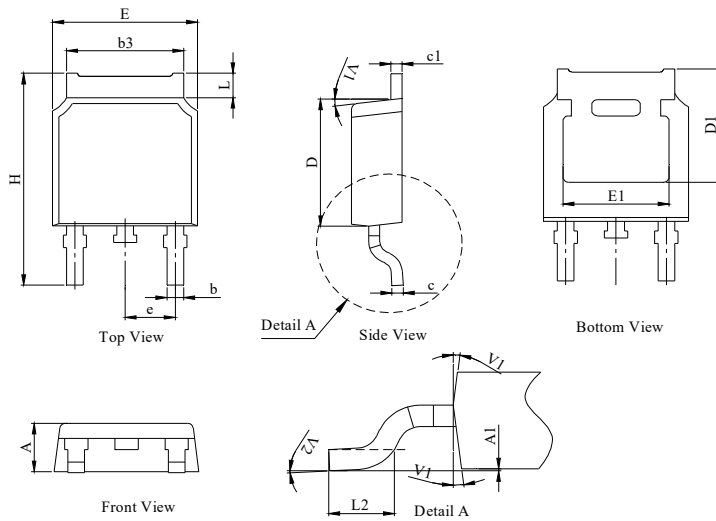

DIM.	MILLIMETER		
	MIN.	NOM.	MAX.
A	2.10	2.30	2.40
A1	0	--	0.13
b	0.66	0.76	0.86
b3	5.21	5.38	5.55
c	0.40	0.50	0.60
c1	0.44	0.50	0.58
D	5.90	6.10	6.30
D1	5.30REF		
E	6.40	6.60	6.80
E1	4.63	-	-
e	2.29 BSC		
H	9.50	10.00	10.70
L	1.09	--	1.21
L2	1.35	--	1.65
V1	7° REF		
V2	0°	--	6°

### Recommended Soldering Footprint

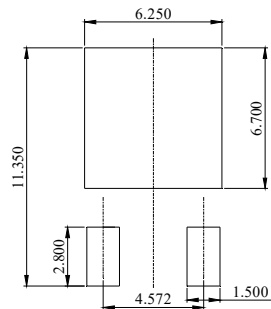

## Tape & Reel Information

Dimensions in mm

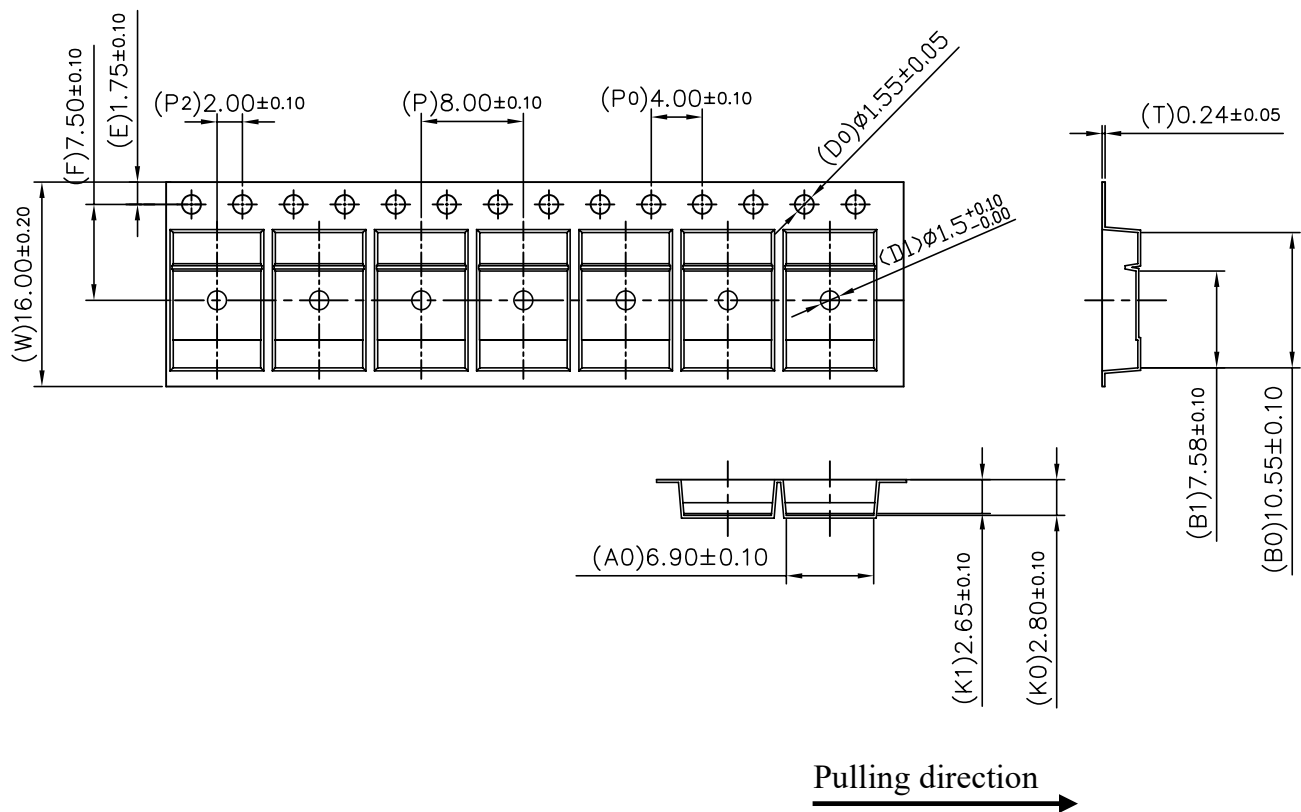
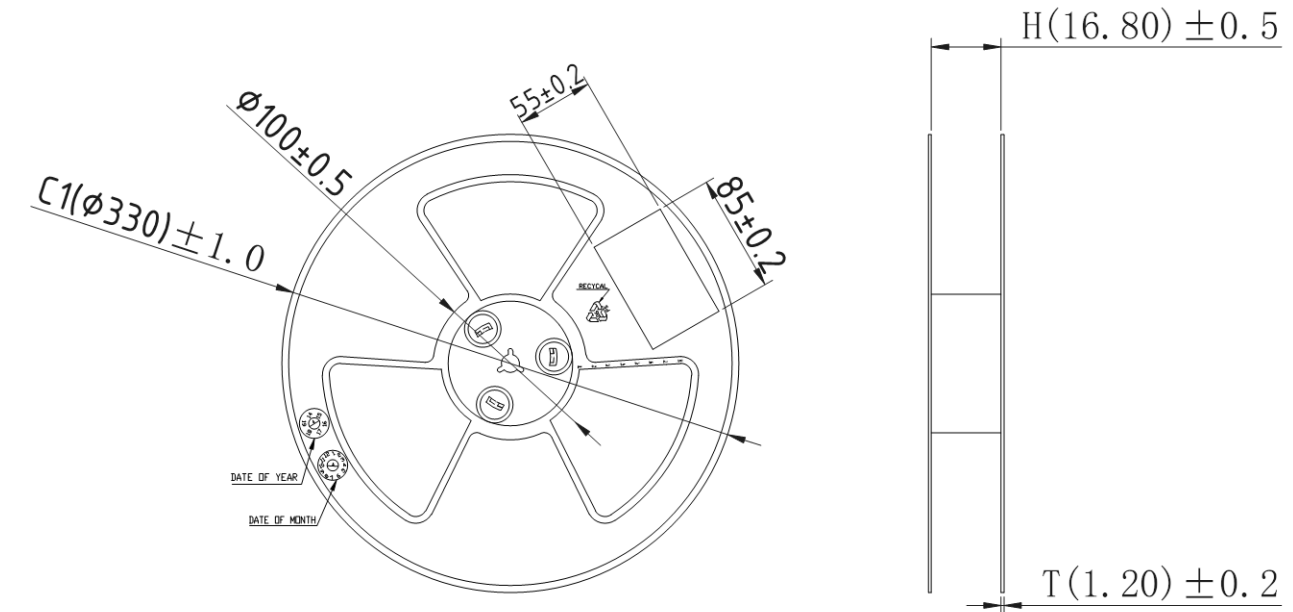

## Marking Information:

- ①. Doingter LOGO
- ②. Date Code(YWWG / R)  
 Y : Year Code , last digit of the year  
 WW : Week Code(01-53)  
 G/R : G(Green) /R(Lead Free)
- ③. Part NO.

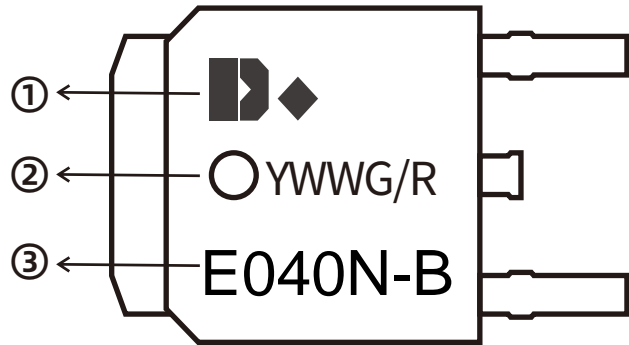

## Previous Version

Version	Date	Subjects (major changes since last revision)
1.0	2025-06-29	Release of final version

## Attention :

- Information furnished in this document is believed to be accurate and reliable. However, Shenzhen Doingter Semiconductor Co.,Ltd. assumes noresponsibility for the consequences of use without consideration for such information nor use beyond it.
- Information mentioned in this document is subject to change without notice, apart from that when an agreement is signed, Shenzhen Doingter complies with the agreement. Products and information provided in this document have no infringement of patents.
- Shenzhen Doingter assumes noresponsibility for any infringement of other rights of third parties which may result from the use of such products and information. This document supersedes and replaces all information previously supplied.



Is a registered trademark of Shenzhen Doingter Semiconductor Co., Ltd. Copyright © 2013 Shenzhen Doingter Semiconductor Co.,Ltd. Printed All rights reserved.