

Rev No.	Description of Revision	Date	Name	Approved	ECN No.

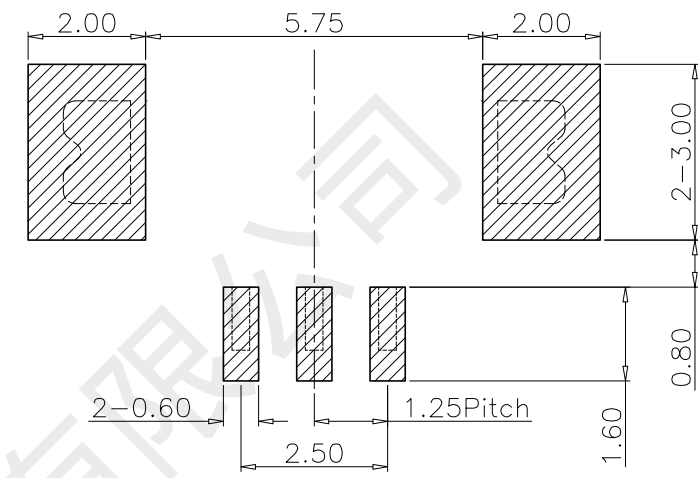

RECOMMENDER P.C.B LAYOUT TOP VIEW  
(GENERAL TOLERANCE ±0.10)

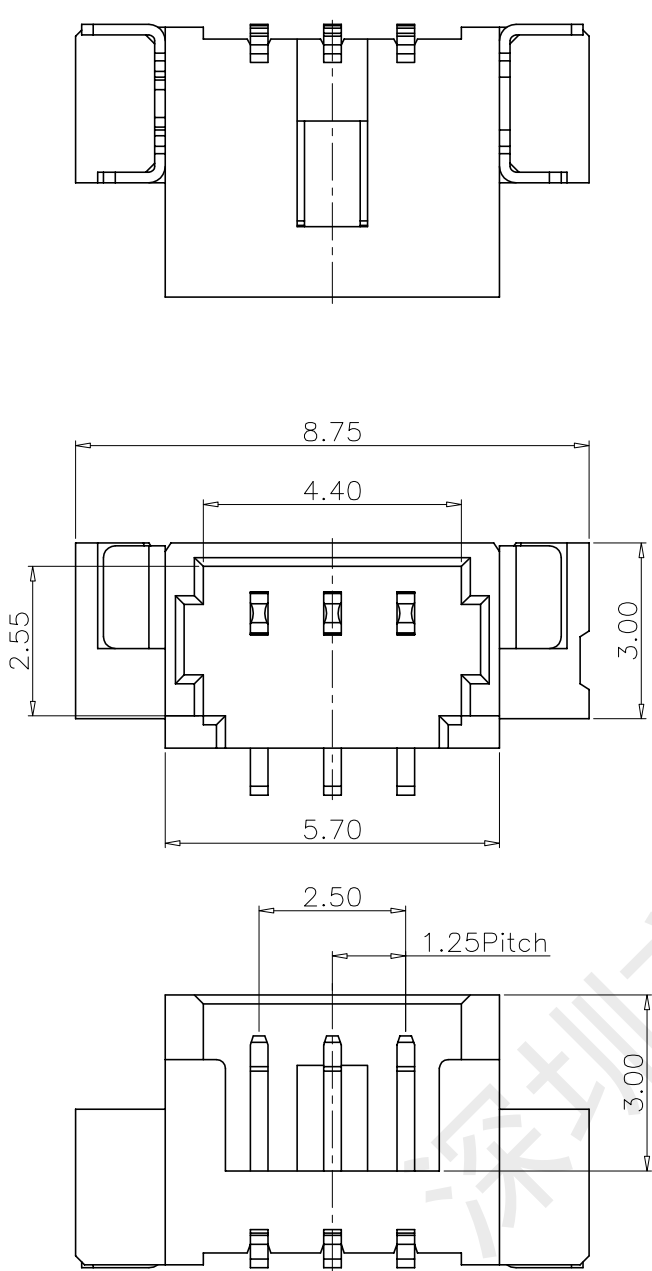
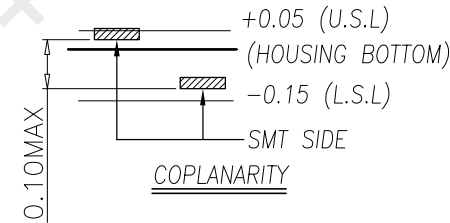
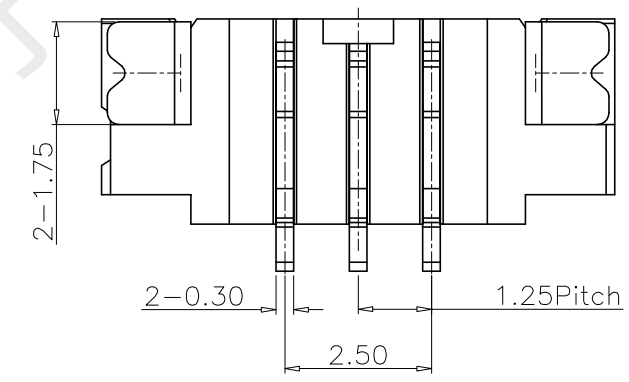

- Specifications:
- Rated Voltage :125V AC/DC
  - Rated Current :1A AC,DC
  - Withstand Voltage :200V AC/minute
  - Contact Resistance:50mΩ (MAX.)
  - Insulation Resistance:100mΩ (MIN.)
  - Storage Temperature Range:-40°C~+85°C;
  - Operation Temperature Range:-25°C~+70°C;

③	端子	黄铜H65	镀亮锡	3PCS
②	固定片	黄铜H65	镀亮锡	2PCS
①	塑胶主体	LCP	本色	1PCS
序号	配件名称	材质	电镀颜色	数量

UNLESS OTHERWISE SPECIFIED TOLERANCES

深圳市韩下电子有限公司 HANXIA

TITLE: HX-1.25-3ALB wire to board plug connector

DECIMALS:	ANGLES	Drwn:	PART NO
X. ±0.15	X' ±2'	Checked:	SCALE 1:8 UNIT mm PROJ:
X.X ±0.10	X.X' ±1'	Approved:	SIZE A4 SHEET 1 OF 1 REV. A
X.XX ±0.05	X.XX' ±0.5'	CUSTOMER COPY	
X.XXX ±0.03			



深圳市韩下电子有限公司

Shenzhen Hanxia Electronic Co., Ltd  
Tel: 0755-23086569 Email: shouhan3@so-han.com

承 认 书  
SPECIFICATION FOR APPROVAL

产品编码  
Material code:

\_\_\_\_\_

产品名称 Project:

针座

\_\_\_\_\_

规格型号 Part No:

HX-1.25-3ALB wire to board plug connector

\_\_\_\_\_

贵公司承认印 Approval signatures

料号/Part No.	签章/Signatures

日期 Date:

拟制/Drawn	黄彬	
审核/Check	张伟	
批准/Approved	罗小春	