

Rev No.	Description of Revision	Date	Name	Approved	ECN No.

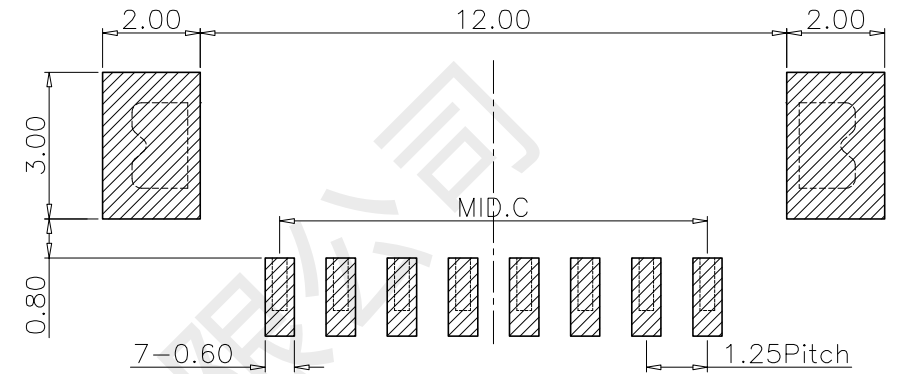

RECOMMENDER P.C.B LAYOUT TOP VIEW
(GENERAL TOLERANCE ±0.10)

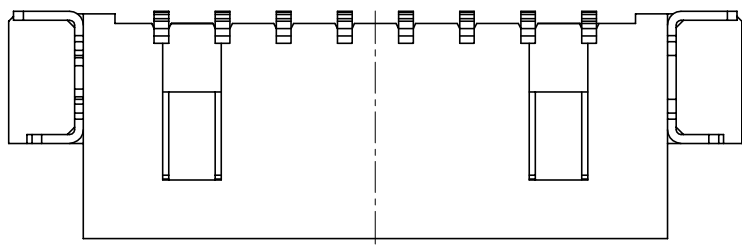
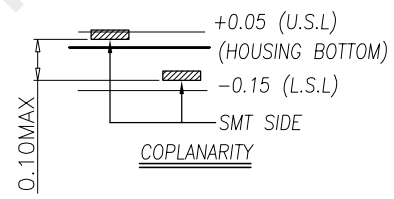
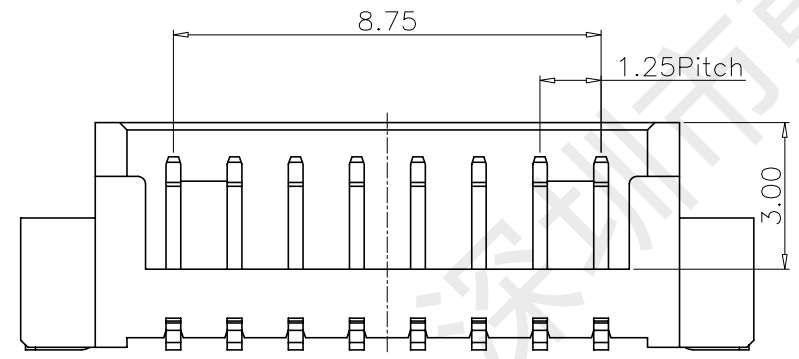
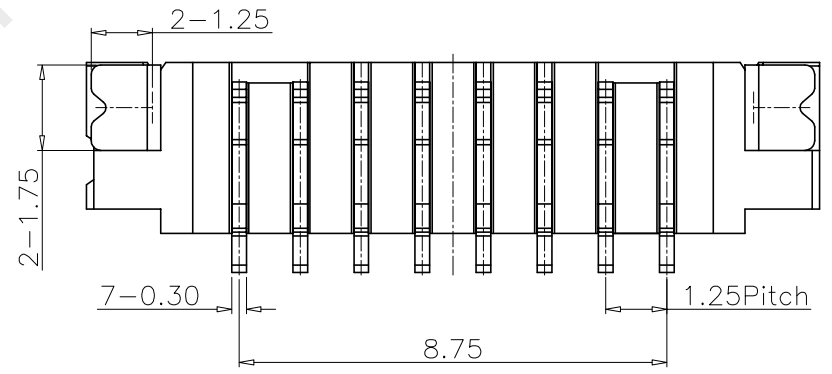
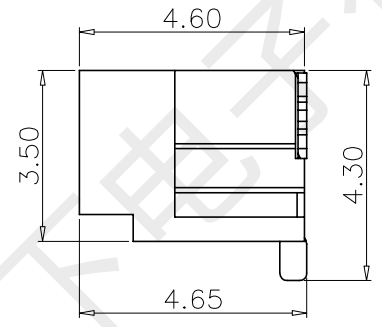
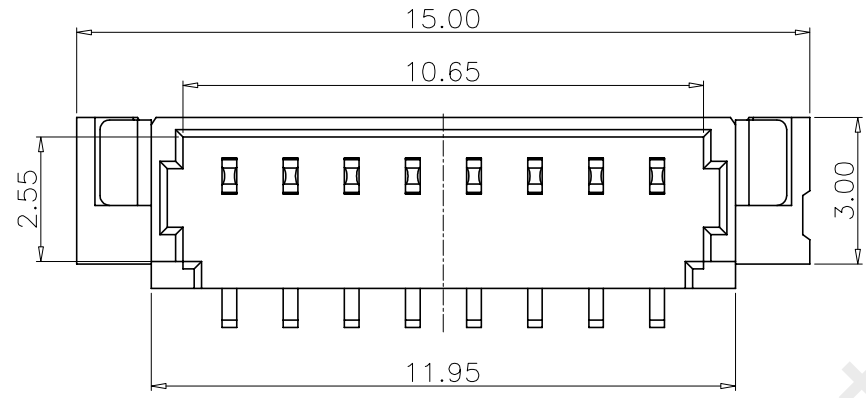

- Specifacatons:
- 1.Rated Voltage :125V AC/DC
 - 2.Rated Current :1A AC,DC
 - 3.Withstand Voltage :200V AC/minute
 - 4.Contact Resistance:50mΩ (MAX.)
 - 5.Insulation Resistance:100mΩ (MIN.)
 - 6.Storage Temperature Range:-40°C~+85°C;
 - 7.Operation Temperature Range:-25°C~+70°C;

③	端子	黄铜H65	镀亮锡	8PCS
②	固定片	黄铜H65	镀亮锡	2PCS
①	塑胶主体	LCP	本色	1PCS
序号	配件名称	材质	电镀颜色	数量

UNLESS OTHERWISE SPECIFIED TOLERANCES					
DECIMALS:	ANGLES	TITLE: HX-1.25-8ALB			
X. ±0.15	X' ±2'	Drwn: 黄彬	PART NO. WF002-LT12508-01		
X.X ±0.10	X.X' ±1'	Checked: 张伟	SCALE: 1:8	UNIT: mm	PROJ:
X.XX ±0.05	X.XX' ±0.5'	Approved: 罗小春	SIZE: A4	SHEET: 1 OF 1	REV: A
X.XXX ±0.03		CUSTOMER COPY			



深圳市韩下电子有限公司

Shenzhen Hanxia Electronic Co., Ltd
Tel: 0755-23086569

承 认 书

SPECIFICATION FOR APPROVAL

产品编码

Material code:

产品名称 Project:

针座

规格型号 Part No:

HX-1.25-8ALB

贵公司承认印 Approval signatures

料号/Part No.	签章/Signatures

日期 Date:

拟制/Drawn	黄彬	
审核/Check	张伟	
批准/Approved	罗小春	