

SMAF SCHOTTKY BARRIER DIODE

FEATURES

- The plastic package carries Underwrites Laboratory Flammability Classification 94V-0
- Construction utilizes void-free molded plastic technique
- High reliability
- High temperature soldering guaranteed: 260 °C/10 seconds at terminals
- Component in accordance to RoHs 2015/863 and WEEE 2012/19/EU

MECHANICAL DATA

- Case style: SMA molded plastic
- Mounting position: Any

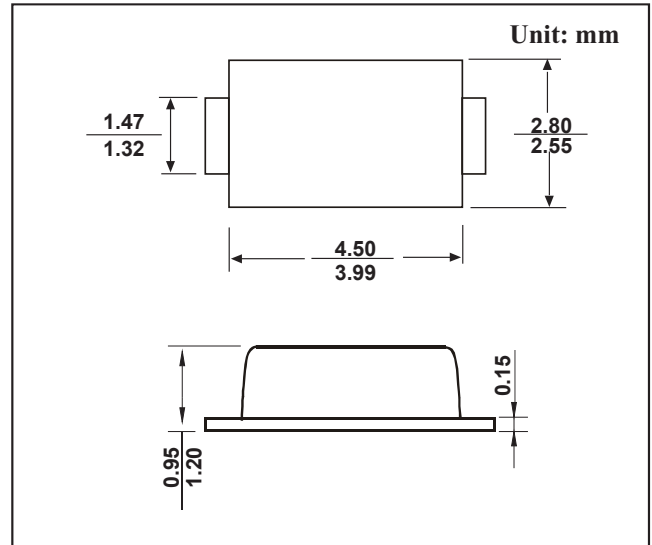

MAXIMUM RATINGS AND CHARACTERISTICS

@ 25°C Ambient Temperature (unless otherwise noted)

TYPE NUMBER	SYMBOL	SS12F	SS13F	SS14F	SS15F	SS16F	SS18F	SS110F	SS115F	SS120F	UNITS
Maximum recurrent peak reverse voltage	V_{RRM}	20	30	40	50	60	80	100	150	200	V
Maximum RMS voltage	V_{RMS}	14	21	28	35	42	56	70	105	140	V
Maximum DC blocking voltage	V_{DC}	20	30	40	50	60	80	100	150	200	V
Maximum Average Forward rectified Current 0.375" (9.5mm) lead length	$I_{F(AV)}$	1.0									A
Peak forward surge current 8.3ms single half sine-wave superimposed on rated load	I_{FSM}	30.0									A
Maximum instantaneous forward voltage at 1.0 A (Note 1)	V_F	0.45	0.55	0.70		0.85				V	
Maximum reverse current at rated DC blocking voltage per diode	@ $T_A=25^\circ\text{C}$	0.5									mA
	@ $T_A=100^\circ\text{C}$	6.0			5.0						
Typical Thermal Resistance	$R_{\theta JA}$	88.0									°C/W
Typical junction capacitance	C_j	110				90					pF
Storage Temperature	T_{STG}	- 55 ---- + 150									°C
Operation Junction Temperature	T_j	- 55 ---- + 125				-55 to +150					°C

RATINGS AND CHARACTERISTIC CURVES

FIG. 1- FORWARD CURRENT DERATING CURVE

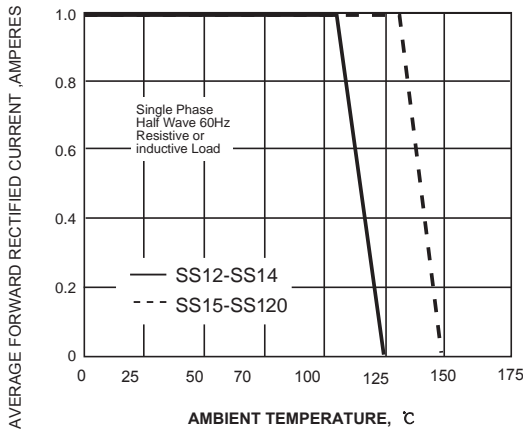

FIG. 2-MAXIMUM NON-REPETITIVE PEAK FORWARD SURGE CURRENT

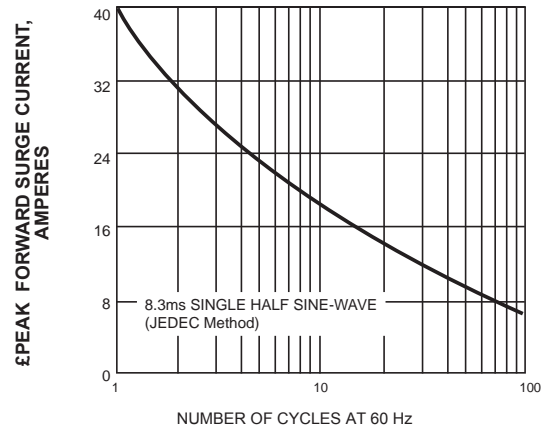

FIG. 3-TYPICAL INSTANTANEOUS FORWARD CHARACTERISTICS

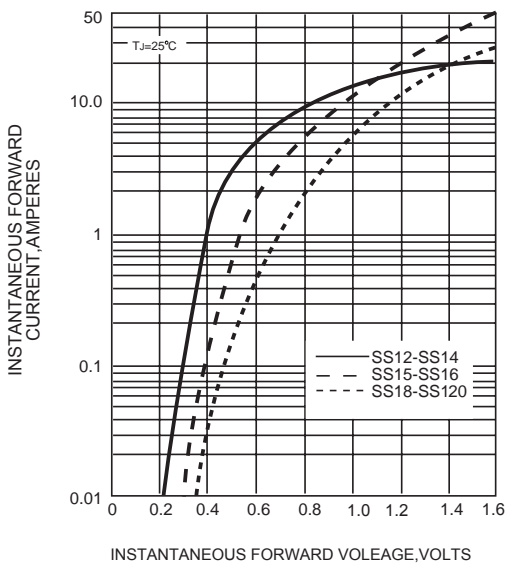

FIG. 4-TYPICAL REVERSE CHARACTERISTICS

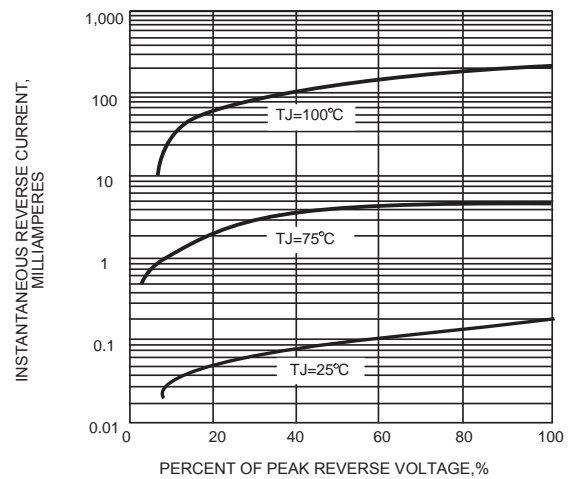

FIG. 5-TYPICAL JUNCTION CAPACITANCE

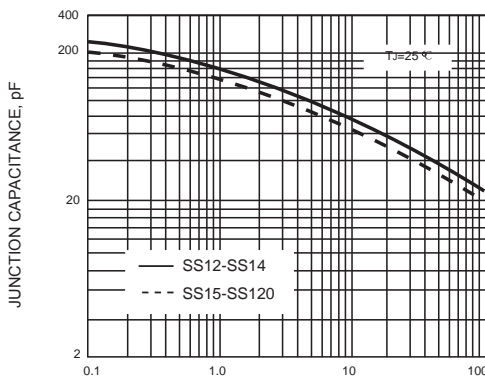

FIG. 6-TYPICAL TRANSIENT THERMAL IMPEDANCE

