

L7805 Three-terminal positive voltage regulator

FEATURES

Maximum Output current I_{OM} : 1.5 A
Output voltage V_o : 5V
Continuous total dissipation
 P_D : 1.5 W ($T_a = 25^\circ\text{C}$)
 15 W ($T_c = 25^\circ\text{C}$)

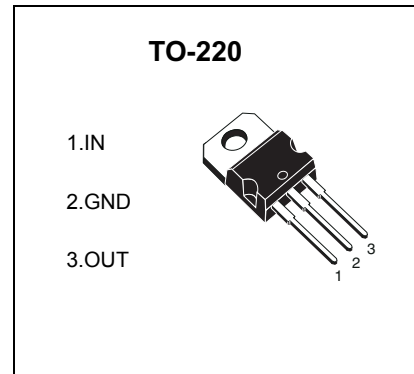

ABSOLUTE MAXIMUM RATINGS (Operating temperature range applies unless otherwise specified)

Parameter	Symbol	Value	Unit
Input Voltage	V_i	35	V
Thermal Resistance from Junction to Ambient	$R_{\theta JA}$	83.3	$^\circ\text{C}/\text{W}$
Thermal Resistance from Junction to Case	$R_{\theta JC}$	8.3	$^\circ\text{C}/\text{W}$
Operating Junction Temperature Range	T_{OPR}	0~+150	$^\circ\text{C}$
Storage Temperature Range	T_{STG}	-55~+150	$^\circ\text{C}$

ELECTRICAL CHARACTERISTICS AT SPECIFIED VIRTUAL JUNCTION TEMPERATURE ($V_i=10\text{V}, I_o=500\text{mA}, C_i=0.33\mu\text{F}, C_o=0.1\mu\text{F}$, unless otherwise specified)

Parameter	Symbol	Test conditions	Min	Typ	Max	Unit
Output voltage	V_o	25°C	4.8	5.0	5.2	V
		$7\text{V} \leq V_i \leq 20\text{V}, I_o=5\text{mA}-1\text{A}, P \leq 15\text{W}$ $0-125^\circ\text{C}$	4.75	5.00	5.25	V
Load Regulation	ΔV_o	$I_o=5\text{mA}-1.5\text{A}$ 25°C		9	100	mV
		$I_o=250\text{mA}-750\text{mA}$ 25°C		4	50	mV
Line regulation	ΔV_o	$7\text{V} \leq V_i \leq 25\text{V}$ 25°C		4	100	mV
		$8\text{V} \leq V_i \leq 12\text{V}$ 25°C		1.6	50	mV
Quiescent Current	I_q	25°C		5	8	mA
Quiescent Current Change	ΔI_q	$7\text{V} \leq V_i \leq 25\text{V}$ $0-125^\circ\text{C}$		0.3	1.3	mA
		$5\text{mA} \leq I_o \leq 1\text{A}$ $0-125^\circ\text{C}$		0.03	0.5	mA
Output Noise Voltage	V_N	$10\text{Hz} \leq f \leq 100\text{KHz}$ 25°C		42		μV
Output voltage drift	$\Delta V_o / \Delta T$	$I_o=5\text{mA}$ $0-125^\circ\text{C}$		-1.1		$\text{mV}/^\circ\text{C}$
Ripple Rejection	RR	$8\text{V} \leq V_i \leq 18\text{V}, f=120\text{Hz}$ $0-125^\circ\text{C}$	62	73		dB
Dropout Voltage	V_d	$I_o=1\text{A}$ 25°C		2		V
Output resistance	R_o	$f=1\text{KHz}$ 25°C		10		$\text{m}\Omega$
Short Circuit Current	I_{sc}	25°C		230		mA
Peak Current	I_{pk}	25°C		2.2		A

TYPICAL APPLICATION

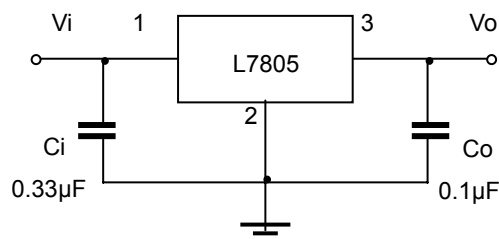

Typical Characteristics

