

Product summary

V_{DS} (V)	$R_{DS(on),max}$ (m Ω)	I_D (A)
100	12 @ $V_{GS} = 10V$	43 ⁽¹⁾

Features

- Low RDS(on) SGT technology
- Low thermal impedance
- Fast switching speed
- 100% avalanche tested.

Applications

- DC/DC conversion
- Power switch
- Motor drives

1. Maximum ratings

Absolute maximum ratings ($T_A = 25^\circ\text{C}$ unless otherwise noted)				
Parameter		Symbol	Limit	Unit
Drain-source voltage		V_{DS}	100	V
Gate-source voltage		V_{GS}	± 20	
Continuous drain current	$T_C = 25^\circ\text{C}$ ⁽¹⁾	I_D	43	A
	$T_C = 100^\circ\text{C}$		27	
	$T_A = 25^\circ\text{C}$ ⁽⁴⁾		11	
Pulsed drain current ⁽²⁾		$I_{D,pulse}$	172	
Avalanche energy, single pulse ⁽³⁾		E_{AS}	31	mJ
Power dissipation	$T_C = 25^\circ\text{C}$	P_D	43.1	W
	$T_A = 25^\circ\text{C}$ ⁽⁴⁾		2.7	
Operating junction and storage temperature range		T_J, T_{stg}	-55 to 150	$^\circ\text{C}$

2. Thermal resistance ratings

Thermal resistance ratings			
Parameter		Symbol	Max. Unit
Thermal resistance, junction-to-case	Steady state	$R_{\theta JC}$	2.9
Thermal resistance, junction-to-ambient ⁽⁴⁾	Steady state	$R_{\theta JA}$	45

3. Electrical Characteristics

Electrical characteristics						
Parameter	Symbol	Test conditions	Min.	Typ.	Max.	Unit
Static parameter						
Drain to source breakdown voltage	$V_{(BR)DSS}$	$V_{GS} = 0\text{ V}, I_D = 250\ \mu\text{A}$	100			V
Gate-source threshold voltage	$V_{GS(th)}$	$V_{DS} = V_{GS}, I_D = 250\ \mu\text{A}$	1.1	1.8	2.5	V
Gate-body leakage	I_{GSS}	$V_{DS} = 0\text{ V}, V_{GS} = \pm 20\text{ V}$			± 100	nA
Zero gate voltage drain current	I_{DSS}	$V_{DS} = 100\text{ V}, V_{GS} = 0\text{ V}$			1	μA
Drain-source on-resistance	$R_{DS(on)}$	$V_{GS} = 4.5\text{ V}, I_D = 10\text{ A}$		13.6	18	m Ω
		$V_{GS} = 10\text{ V}, I_D = 10\text{ A}$		9.2	12	
Forward transconductance ⁽⁵⁾	g_{fs}	$V_{DS} = 5\text{ V}, I_D = 10\text{ A}$		23		S
Gate resistance	R_g	$f = 1\text{ MHz}$		1.6		Ω
Dynamic⁽⁵⁾						
Total gate charge	Q_g	$V_{DS} = 50\text{ V}, I_D = 10\text{ A}, V_{GS} = 10\text{ V}$		31		nC
Total gate charge	Q_g	$V_{DS} = 50\text{ V}, I_D = 10\text{ A}, V_{GS} = 4.5\text{ V}$		17.2		
Gate-source charge	Q_{gs}			4.3		
Gate-drain charge	Q_{gd}			9.4		
Turn-on delay time	$t_{d(on)}$	$V_{DS} = 50\text{ V}, I_D = 10\text{ A}, V_{GS} = 10\text{ V}, R_{GEN} = 4.7\ \Omega$		7		ns
Rise time	t_r			17		
Turn-off delay time	$t_{d(off)}$			28		
Fall time	t_f			27		
Input capacitance	C_{iss}	$V_{DS} = 50\text{ V}, V_{GS} = 0\text{ V}, f = 1\text{ MHz}$		1470		pF
Output capacitance	C_{oss}			230		
Reverse transfer capacitance	C_{rss}			11		
Reverse Diode Characteristics⁽⁵⁾						
Diode forward voltage	V_{SD}	$V_{GS} = 0\text{ V}, I_F = 10\text{ A}$		0.8	1.1	V
Reverse recovery time	t_{rr}	$V_{DS} = 50\text{ V}, I_F = 10\text{ A}, di/dt = 100\text{ A}/\mu\text{s}$		41		ns
Reverse recovery charge	Q_{rr}			44		nC

Notes

- Limited by maximum junction temperature.
- Pulse width limited by maximum junction temperature.
- $V_{DS} = 50\text{ V}, V_{GS} = 10\text{ V}, L = 0.1\text{ mH}$.
- $R_{\theta JA}$ is determined with the device mounted on a 1 in² pad 2 oz copper pad on a 1.5x1.5 in. board of FR-4 material.
- Guaranteed by design, not subject to production testing.

4. Electrical characteristics diagrams

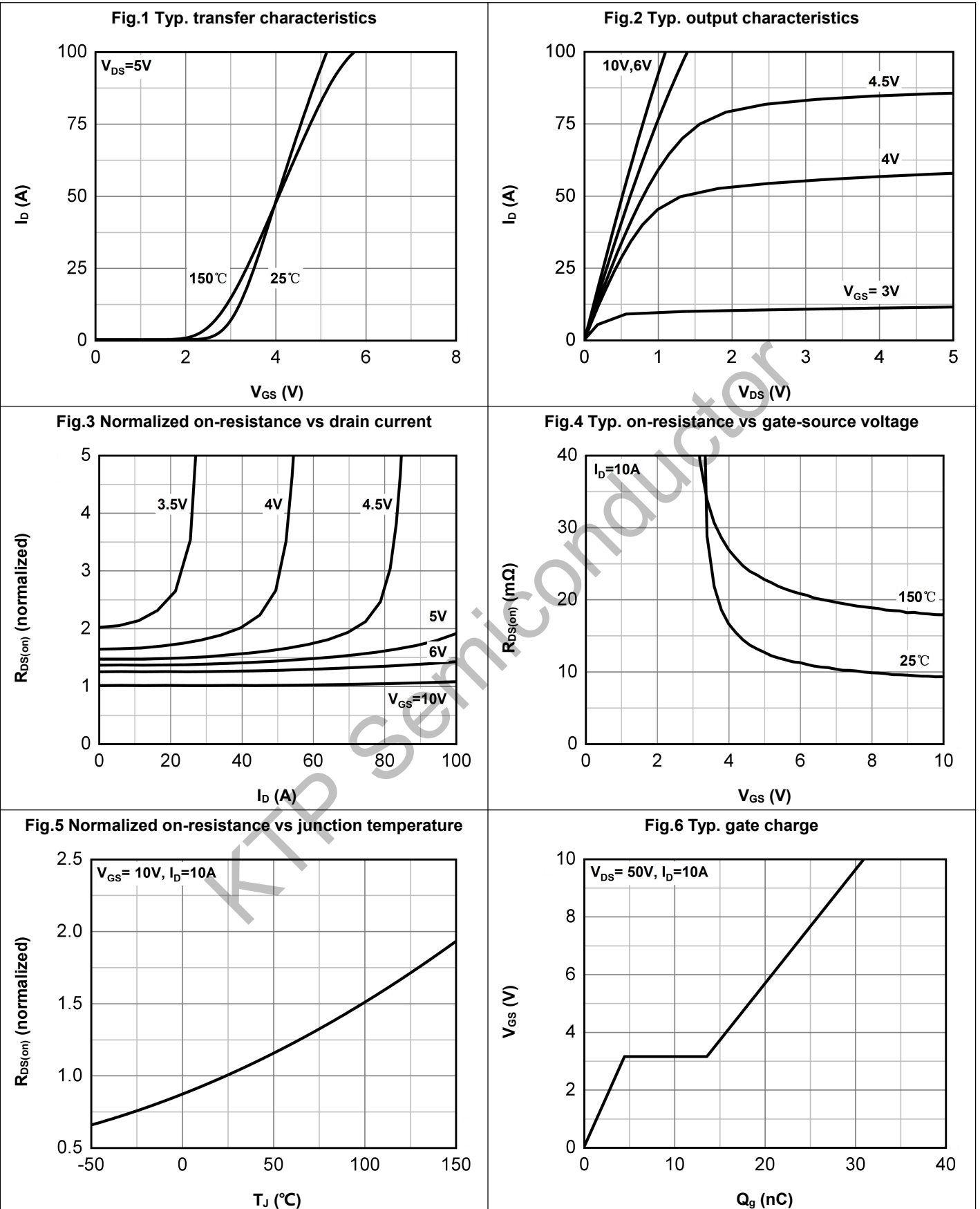

Fig.7 Typ. forward characteristics of body diode

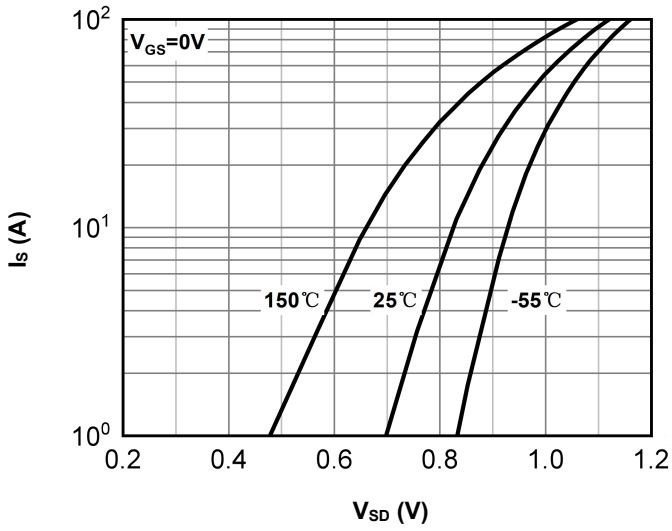

Fig.8 Safe operating area

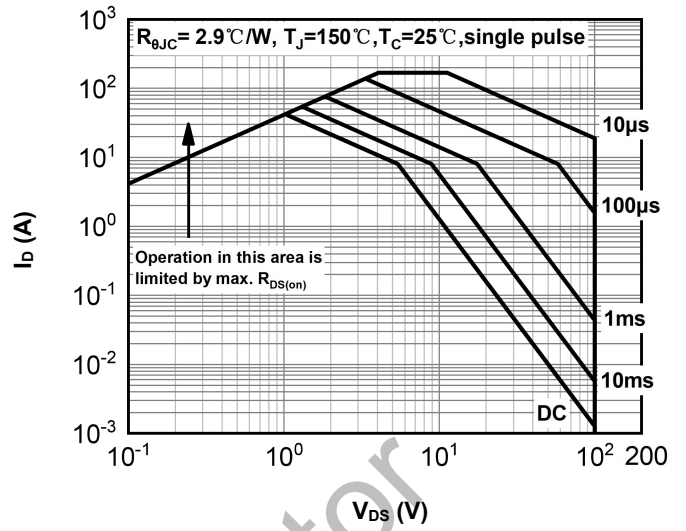

Fig.9 Typ. Capacitance

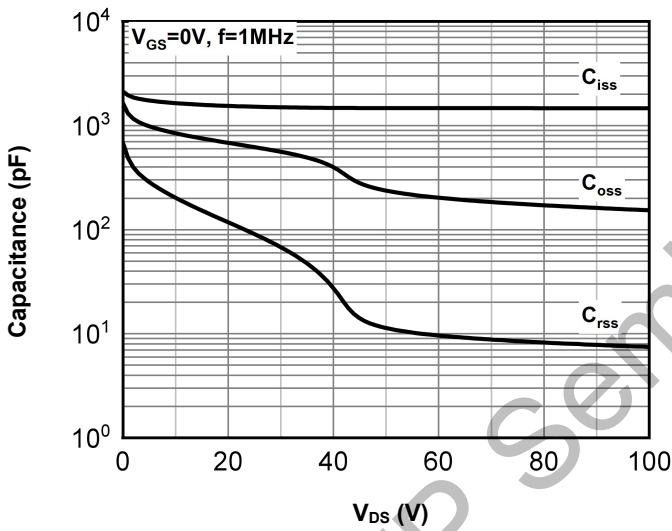

Fig.10 Single pulse maximum power dissipation

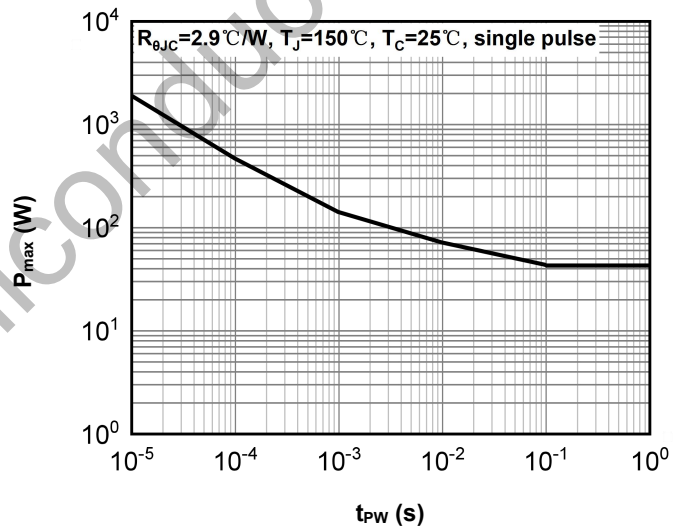

Fig.11 Max. power dissipation vs case temperature

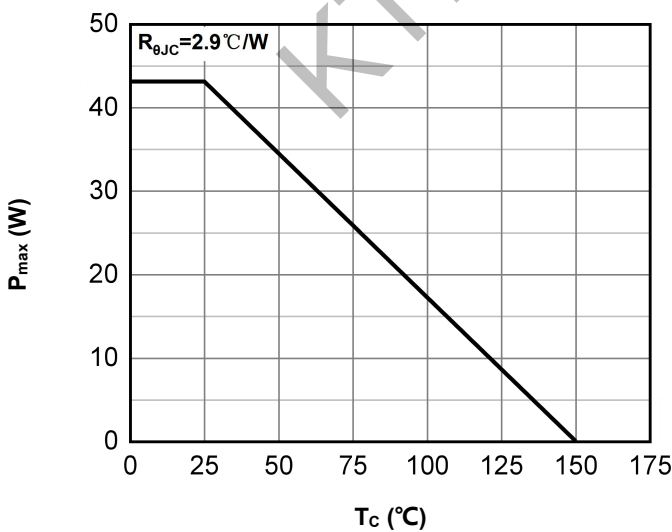

Fig.12 Max. continuous drain current vs case temperature

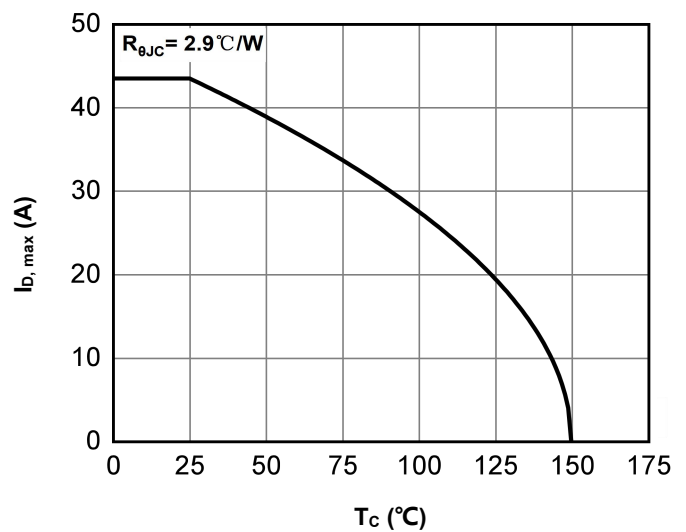

Fig.13 Normalized $V_{(BR)DSS}$ vs junction temperature

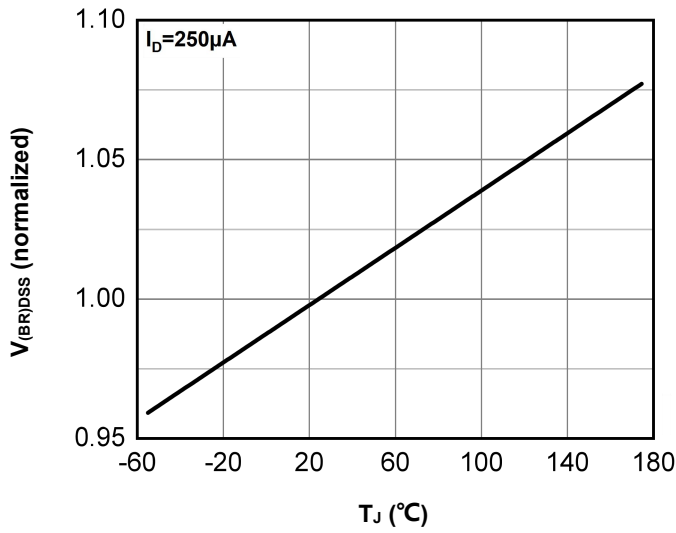

Fig.14 Normalized $V_{GS(th)}$ vs junction temperature

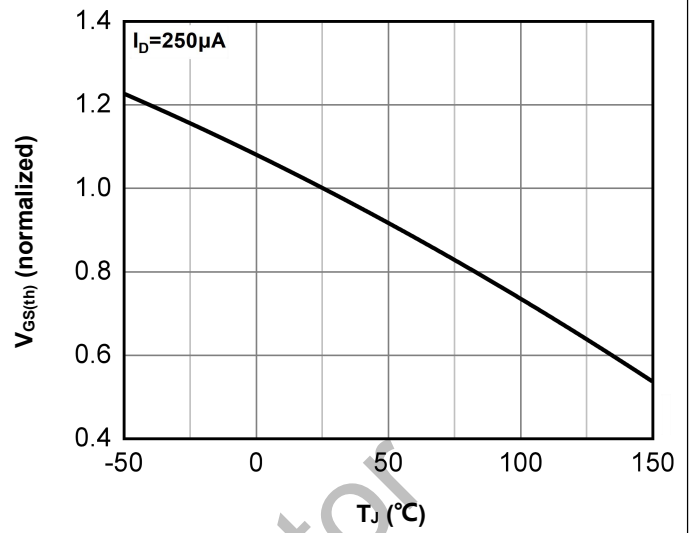
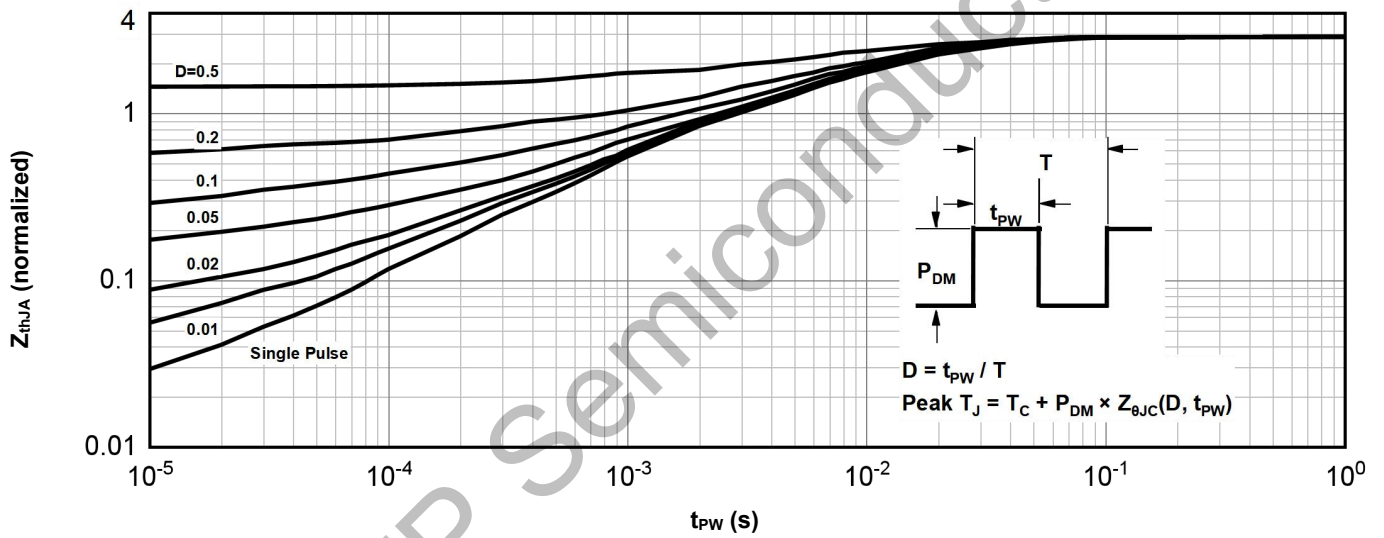
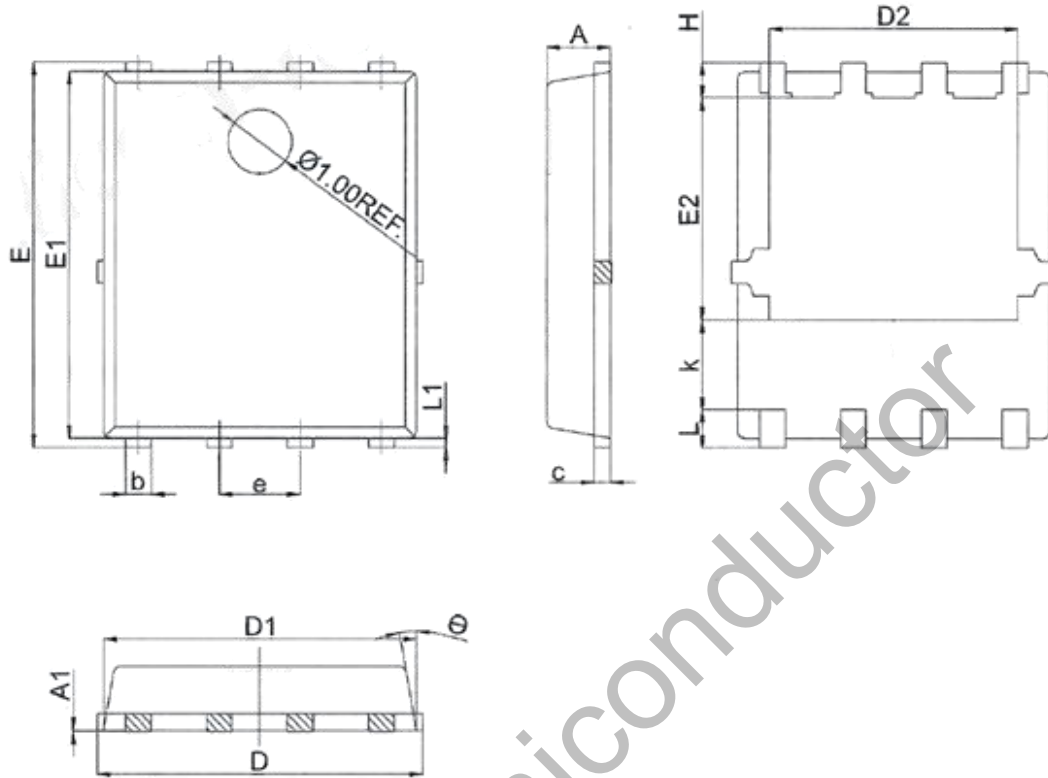

Fig.15 Normalized transient thermal impedance from junction to ambient



5. Package outline dimensions

PDFN5*6



Dim	Millimeters		
	Min	Nom	Max
A	0.90	1.00	1.10
A1	—	—	0.05
b	0.30	0.40	0.50
c	0.20	0.25	0.30
D	4.80	5.10	5.40
D1	4.80	4.90	5.00
D2	3.75	3.90	4.11
E	5.95	6.05	6.15
E1	5.65	5.75	5.85
E2	3.34	3.49	3.64
e	1.27 BSC		
H	0.46	0.56	0.726
k	1.10	—	—
L	0.51	0.61	0.71
L1	0.05	0.15	0.25
θ	8°	10°	12°