

# Features/产品特点

1. Wide operating temperature range: -40 °C to+125 °C
2. Isolation voltage 3000VDC
3. SMD package
4. Industry standard pin
5. Toroidal core structure

1. 工作温度范围广：-40°C至+125°C
2. 隔离电压3000VDC
3. SMD封装
4. 行业标准引脚
5. 环形磁芯结构



## Power Solutions

DC-DC isolation transformer  
DC-DC隔离变压器

## TE-1W/2W

Series/系列

## Description/概述

TE-1W/2W series DC-DC isolation transformer is a high-performance ring transformer specially designed for use with various power management chips, which can provide input and output isolation. It can precisely customize the turn ratio for customers to achieve high-precision voltage conversion and isolation.

TE-1W/2W 系列DC-DC隔离变压器是一种与各类电源管理芯片配合使用而专门设计的、可以提供输入与输出隔离的高性能环形变压器，可为客户精确定制匝数比，实现高精度电压转换和隔离。

## Model Numbering/命名规则

**TE 0305 -1W 6A P(N) T(R)**

- Packaging form/包装方式
- Potting code/灌封代码
- Appearance code/外形代码
- Output power/输出功率
- Typical voltage/典型电压
- Series/系列

Series/系列	Winding/绕组	Isolation voltage/隔离电压
TA	4	1500VDC
TB	3	1500VDC
TE	4	3000VDC
TF	3	3000VDC
TG	4	6000VDC
TH	3	6000VDC

Potting code/灌封代码:

P- Potting(灌封), N- Non potting (非灌封)

Packaging form/包装方式:

T- Tube (管装), R- Reel (卷盘包装)

TR- Tray(托盘包装)

Packaging/封装

封装代号: 6A/Package code: 6A

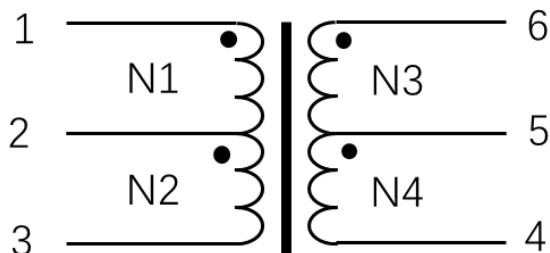
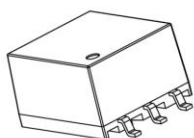
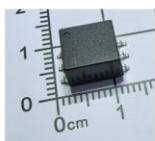
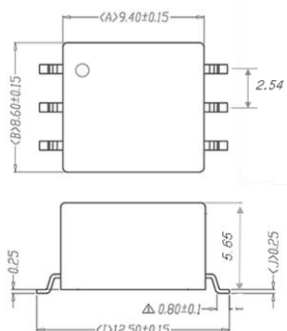

封装代号: 6B/Package code: 6B

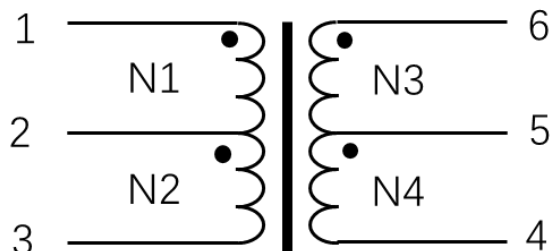
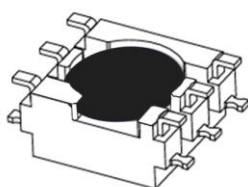
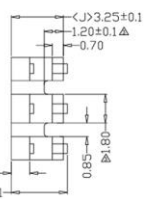
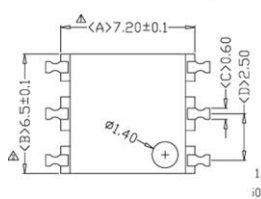

封装代号: 6C/Package code: 6C

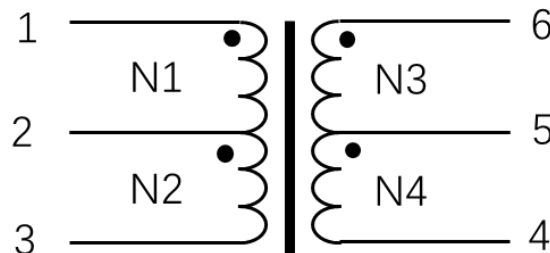
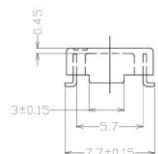
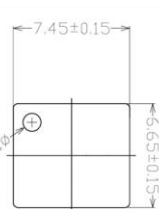
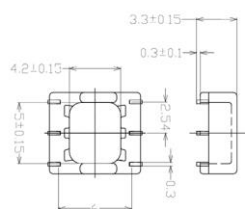

Packaging/封装

封装代号: 6D/Package code: 6D

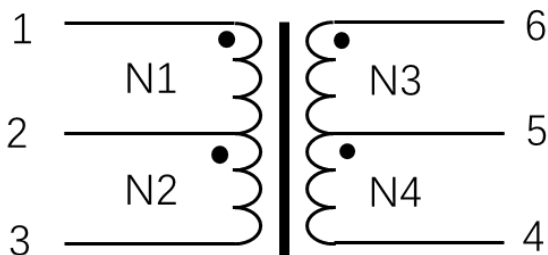
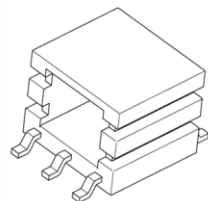
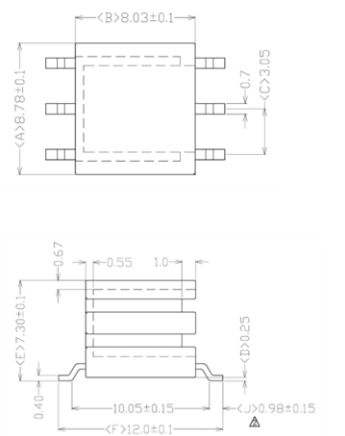

封装代号: 6E/Package code: 6E

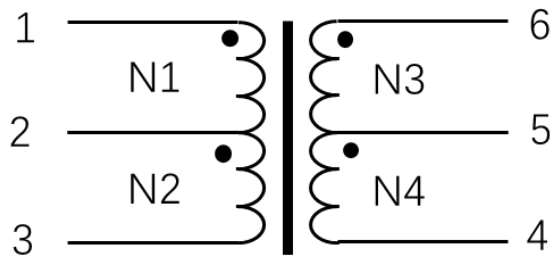
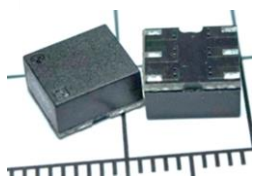
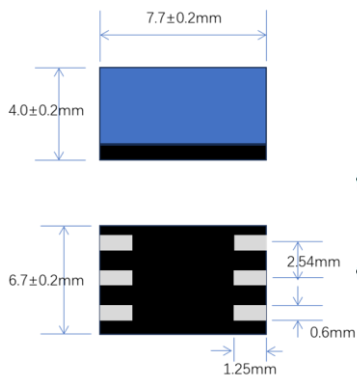

封装代号: 8A/Package code: 8A

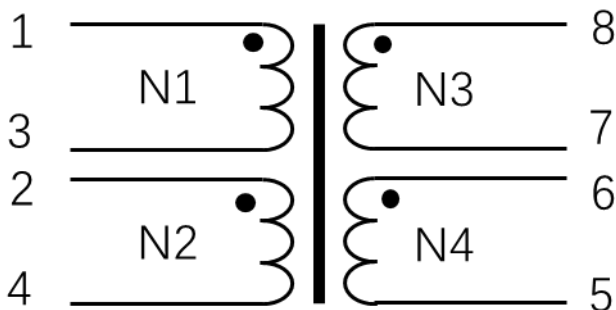
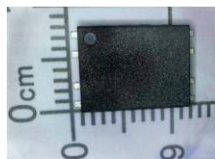
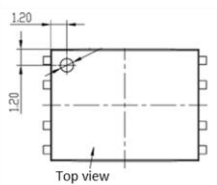
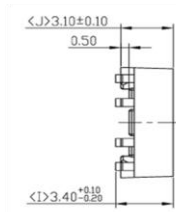
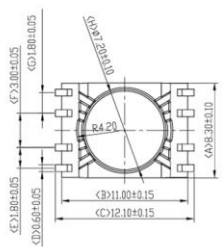

## Selection Guide/选型表

本产品支持定制，如需其他规格请联系我司业务人员，谢谢。

This product supports customization. If you require other specifications, please contact our sales personnel. Thank you.

### 3.3VDC输入/ 3.3V DC Input

封装代号：6A/Package code: 6A

产品型号 Product model	Input VDC	Output VDC	匝比 Turns ratio	初级电感量-LP Primary Inductance (+/-20%) @1kHz, 1V	初级电阻-RDC Primary D.C. Resistance (Max)	峰值电流-IPK Peak current (Max)	绕组 winding	封装 packaging
TE0303-1W6AN(P)T(R)	3.3	3.3	1:1.16	360μH	0.5Ω	400mA	4	6A
TE0303-2W6AN(P)T(R)	3.3	3.3	1:1.16	180μH	0.3Ω	600mA	4	6A
TE0305-1W6AN(P)T(R)	3.3	5	1:1.71	360μH	0.5Ω	400mA	4	6A
TE0305-2W6AN(P)T(R)	3.3	5	1:1.71	180μH	0.3Ω	600mA	4	6A

封装代号：6B/Package code: 6B

产品型号 Product model	Input VDC	Output VDC	匝比 Turns ratio	初级电感量-LP Primary Inductance (+/-20%) @1kHz, 1V	初级电阻-RDC Primary D.C. Resistance (Max)	峰值电流-IPK Peak current (Max)	绕组 winding	封装 packaging
TE0303-1W6BN(P)T(R)	3.3	3.3	1:1.16	360μH	0.5Ω	400mA	4	6B
TE0303-2W6BN(P)T(R)	3.3	3.3	1:1.16	180μH	0.3Ω	600mA	4	6B
TE0305-1W6BN(P)T(R)	3.3	5	1:1.71	360μH	0.5Ω	400mA	4	6B
TE0305-2W6BN(P)T(R)	3.3	5	1:1.71	180μH	0.3Ω	600mA	4	6B

封装代号：6C/Package code: 6C

产品型号 Product model	Input VDC	Output VDC	匝比 Turns ratio	初级电感量-LP Primary Inductance (+/-20%) @1kHz, 1V	初级电阻-RDC Primary D.C. Resistance (Max)	峰值电流-IPK Peak current (Max)	绕组 winding	封装 packaging
TE0303-1W6CN(P)T(R)	3.3	3.3	1:1.16	360μH	0.5Ω	400mA	4	6C
TE0303-2W6CN(P)T(R)	3.3	3.3	1:1.16	180μH	0.3Ω	600mA	4	6C
TE0305-1W6CN(P)T(R)	3.3	5	1:1.71	360μH	0.5Ω	400mA	4	6C
TE0305-2W6CN(P)T(R)	3.3	5	1:1.71	180μH	0.3Ω	600mA	4	6C

封装代号：6D/Package code: 6D

产品型号 Product model	Input VDC	Output VDC	匝比 Turns ratio	初级电感量-LP Primary Inductance (+/-20%) @1kHz, 1V	初级电阻-RDC Primary D.C. Resistance (Max)	峰值电流-IPK Peak current (Max)	绕组 winding	封装 packaging
TE0303-1W6DN(P)T(R)	3.3	3.3	1:1.16	360μH	0.5Ω	400mA	4	6D
TE0303-2W6DN(P)T(R)	3.3	3.3	1:1.16	180μH	0.3Ω	600mA	4	6D
TE0305-1W6DN(P)T(R)	3.3	5	1:1.71	360μH	0.5Ω	400mA	4	6D
TE0305-2W6DN(P)T(R)	3.3	5	1:1.71	180μH	0.3Ω	600mA	4	6D

封装代号: 6E/Package code: 6E

产品型号 Product model	Input VDC	Output VDC	匝比 Turns ratio	初级电感量-LP Primary Inductance (+/-20%) @1kHz, 1V	初级电阻-RDC Primary D.C. Resistance (Max)	峰值电流-IPK Peak current (Max)	绕组 winding	封装 packaging
TE0303-1W6EN(P)T(R)	3.3	3.3	1:1.16	360 $\mu$ H	0.5 $\Omega$	400mA	4	6E
TE0303-2W6EN(P)T(R)	3.3	3.3	1:1.16	180 $\mu$ H	0.3 $\Omega$	600mA	4	6E
TE0305-1W6EN(P)T(R)	3.3	5	1:1.71	360 $\mu$ H	0.5 $\Omega$	400mA	4	6E
TE0305-2W6EN(P)T(R)	3.3	5	1:1.71	180 $\mu$ H	0.3 $\Omega$	600mA	4	6E

封装代号: 8A/Package code: 8A

产品型号 Product model	Input VDC	Output VDC	匝比 Turns ratio	初级电感量-LP Primary Inductance (+/-20%) @1kHz, 1V	初级电阻-RDC Primary D.C. Resistance (Max)	峰值电流-IPK Peak current (Max)	绕组 winding	封装 packaging
TE0303-1W8AN(P)T(R)	3.3	3.3	1:1.16	360 $\mu$ H	0.5 $\Omega$	400mA	4	8A
TE0303-2W8AN(P)T(R)	3.3	3.3	1:1.16	180 $\mu$ H	0.3 $\Omega$	600mA	4	8A
TE0305-1W8AN(P)T(R)	3.3	5	1:1.71	360 $\mu$ H	0.5 $\Omega$	400mA	4	8A
TE0305-2W8AN(P)T(R)	3.3	5	1:1.71	180 $\mu$ H	0.3 $\Omega$	600mA	4	8A

## 5VDC输入 / 5V DC Input

封装代号: 6A/Package code: 6A

产品型号 Product model	Input VDC	Output VDC	匝比 Turns ratio	初级电感量-LP Primary Inductance (+/-20%) @1kHz, 1V	初级电阻-RDC Primary D.C. Resistance (Max)	峰值电流-IPK Peak current (Max)	绕组 winding	封装 packaging
TE0503-1W6AN(P)T(R)	5	3.3	1:0.75	280 $\mu$ H	0.4 $\Omega$	200mA	4	6A
TE0503-2W6AN(P)T(R)	5	3.3	1:0.75	280 $\mu$ H	0.4 $\Omega$	400mA	4	6A
TE0505-1W6AN(P)T(R)	5	5	1:1.13	280 $\mu$ H	0.4 $\Omega$	200mA	4	6A
TE0505-2W6AN(P)T(R)	5	5	1:1.13	280 $\mu$ H	0.4 $\Omega$	400mA	4	6A
TE0509-1W6AN(P)T(R)	5	9	1:1.94	280 $\mu$ H	0.4 $\Omega$	200mA	4	6A
TE0509-2W6AN(P)T(R)	5	9	1:1.94	280 $\mu$ H	0.4 $\Omega$	400mA	4	6A
TE0512-1W6AN(P)T(R)	5	12	1:2.56	280 $\mu$ H	0.4 $\Omega$	200mA	4	6A
TE0512-2W6AN(P)T(R)	5	12	1:2.56	280 $\mu$ H	0.4 $\Omega$	400mA	4	6A
TE0515-1W6AN(P)T(R)	5	15	1:3.21	280 $\mu$ H	0.4 $\Omega$	200mA	4	6A
TE0515-2W6AN(P)T(R)	5	15	1:3.21	280 $\mu$ H	0.4 $\Omega$	400mA	4	6A
TE0524-1W6AN(P)T(R)	5	24	1:4.91	280 $\mu$ H	0.4 $\Omega$	200mA	4	6A
TE0524-2W6AN(P)T(R)	5	24	1:4.91	280 $\mu$ H	0.4 $\Omega$	400mA	4	6A

封装代号: 6B/Package code: 6B

产品型号 Product model	Input VDC	Output VDC	匝比 Turns ratio	初级电感量-LP Primary Inductance (+/-20%) @1kHz, 1V	初级电阻-RDC Primary D.C. Resistance (Max)	峰值电流-IPK Peak current (Max)	绕组 winding	封装 packaging
TE0503-1W6BN(P)T(R)	5	3.3	1:0.75	280μH	0.4Ω	200mA	4	6B
TE0503-2W6BN(P)T(R)	5	3.3	1:0.75	280μH	0.4Ω	400mA	4	6B
TE0505-1W6BN(P)T(R)	5	5	1:1.13	280μH	0.4Ω	200mA	4	6B
TE0505-2W6BN(P)T(R)	5	5	1:1.13	280μH	0.4Ω	400mA	4	6B
TE0509-1W6BN(P)T(R)	5	9	1:1.94	280μH	0.4Ω	200mA	4	6B
TE0509-2W6BN(P)T(R)	5	9	1:1.94	280μH	0.4Ω	400mA	4	6B
TE0512-1W6BN(P)T(R)	5	12	1:2.56	280μH	0.4Ω	200mA	4	6B
TE0512-2W6BN(P)T(R)	5	12	1:2.56	280μH	0.4Ω	400mA	4	6B
TE0515-1W6BN(P)T(R)	5	15	1:3.21	280μH	0.4Ω	200mA	4	6B
TE0515-2W6BN(P)T(R)	5	15	1:3.21	280μH	0.4Ω	400mA	4	6B
TE0524-1W6BN(P)T(R)	5	24	1:4.91	280μH	0.4Ω	200mA	4	6B
TE0524-2W6BN(P)T(R)	5	24	1:4.91	280μH	0.4Ω	400mA	4	6B

封装代号: 6C/Package code: 6C

产品型号 Product model	Input VDC	Output VDC	匝比 Turns ratio	初级电感量-LP Primary Inductance (+/-20%) @1kHz, 1V	初级电阻-RDC Primary D.C. Resistance (Max)	峰值电流-IPK Peak current (Max)	绕组 winding	封装 packaging
TE0503-1W6CN(P)T(R)	5	3.3	1:0.75	280μH	0.4Ω	200mA	4	6C
TE0503-2W6CN(P)T(R)	5	3.3	1:0.75	280μH	0.4Ω	400mA	4	6C
TE0505-1W6CN(P)T(R)	5	5	1:1.13	280μH	0.4Ω	200mA	4	6C
TE0505-2W6CN(P)T(R)	5	5	1:1.13	280μH	0.4Ω	400mA	4	6C
TE0509-1W6CN(P)T(R)	5	9	1:1.94	280μH	0.4Ω	200mA	4	6C
TE0509-2W6CN(P)T(R)	5	9	1:1.94	280μH	0.4Ω	400mA	4	6C
TE0512-1W6CN(P)T(R)	5	12	1:2.56	280μH	0.4Ω	200mA	4	6C
TE0512-2W6CN(P)T(R)	5	12	1:2.56	280μH	0.4Ω	400mA	4	6C
TE0515-1W6CN(P)T(R)	5	15	1:3.21	280μH	0.4Ω	200mA	4	6C
TE0515-2W6CN(P)T(R)	5	15	1:3.21	280μH	0.4Ω	400mA	4	6C
TE0524-1W6CN(P)T(R)	5	24	1:4.91	280μH	0.4Ω	200mA	4	6C
TE0524-2W6CN(P)T(R)	5	24	1:4.91	280μH	0.4Ω	400mA	4	6C

封装代号: 6D/Package code: 6D

产品型号 Product model	Input VDC	Output VDC	匝比 Turns ratio	初级电感量-LP Primary Inductance (+/-20%) @1kHz, 1V	初级电阻-RDC Primary D.C. Resistance (Max)	峰值电流-IPK Peak current (Max)	绕组 winding	封装 packaging
TE0503-1W6DN(P)T(R)	5	3.3	1:0.75	280μH	0.4Ω	200mA	4	6D
TE0503-2W6DN(P)T(R)	5	3.3	1:0.75	280μH	0.4Ω	400mA	4	6D
TE0505-1W6DN(P)T(R)	5	5	1:1.13	280μH	0.4Ω	200mA	4	6D
TE0505-2W6DN(P)T(R)	5	5	1:1.13	280μH	0.4Ω	400mA	4	6D
TE0509-1W6DN(P)T(R)	5	9	1:1.94	280μH	0.4Ω	200mA	4	6D
TE0509-2W6DN(P)T(R)	5	9	1:1.94	280μH	0.4Ω	400mA	4	6D
TE0512-1W6DN(P)T(R)	5	12	1:2.56	280μH	0.4Ω	200mA	4	6D
TE0512-2W6DN(P)T(R)	5	12	1:2.56	280μH	0.4Ω	400mA	4	6D
TE0515-1W6DN(P)T(R)	5	15	1:3.21	280μH	0.4Ω	200mA	4	6D
TE0515-2W6DN(P)T(R)	5	15	1:3.21	280μH	0.4Ω	400mA	4	6D
TE0524-1W6DN(P)T(R)	5	24	1:4.91	280μH	0.4Ω	200mA	4	6D
TE0524-2W6DN(P)T(R)	5	24	1:4.91	280μH	0.4Ω	400mA	4	6D

封装代号: 6E/Package code: 6E

产品型号 Product model	Input VDC	Output VDC	匝比 Turns ratio	初级电感量-LP Primary Inductance (+/-20%) @1kHz, 1V	初级电阻-RDC Primary D.C. Resistance (Max)	峰值电流-IPK Peak current (Max)	绕组 winding	封装 packaging
TE0503-1W6EN(P)T(R)	5	3.3	1:0.75	280μH	0.4Ω	200mA	4	6E
TE0503-2W6EN(P)T(R)	5	3.3	1:0.75	280μH	0.4Ω	400mA	4	6E
TE0505-1W6EN(P)T(R)	5	5	1:1.13	280μH	0.4Ω	200mA	4	6E
TE0505-2W6EN(P)T(R)	5	5	1:1.13	280μH	0.4Ω	400mA	4	6E
TE0509-1W6EN(P)T(R)	5	9	1:1.94	280μH	0.4Ω	200mA	4	6E
TE0509-2W6EN(P)T(R)	5	9	1:1.94	280μH	0.4Ω	400mA	4	6E
TE0512-1W6EN(P)T(R)	5	12	1:2.56	280μH	0.4Ω	200mA	4	6E
TE0512-2W6EN(P)T(R)	5	12	1:2.56	280μH	0.4Ω	400mA	4	6E
TE0515-1W6EN(P)T(R)	5	15	1:3.21	280μH	0.4Ω	200mA	4	6E
TE0515-2W6EN(P)T(R)	5	15	1:3.21	280μH	0.4Ω	400mA	4	6E
TE0524-1W6EN(P)T(R)	5	24	1:4.91	280μH	0.4Ω	200mA	4	6E
TE0524-2W6EN(P)T(R)	5	24	1:4.91	280μH	0.4Ω	400mA	4	6E

封装代号: 8A/Package code: 8A

产品型号 Product model	Input VDC	Output VDC	匝比 Turns ratio	初级电感量-LP Primary Inductance (+/-20%) @1kHz, 1V	初级电阻-RDC Primary D.C. Resistance (Max)	峰值电流-IPK Peak current (Max)	绕组 winding	封装 packaging
TE0503-1W8AN(P)T(R)	5	3.3	1:0.75	280μH	0.4Ω	200mA	4	8A
TE0503-2W8AN(P)T(R)	5	3.3	1:0.75	280μH	0.4Ω	400mA	4	8A
TE0505-1W8AN(P)T(R)	5	5	1:1.13	280μH	0.4Ω	200mA	4	8A
TE0505-2W8AN(P)T(R)	5	5	1:1.13	280μH	0.4Ω	400mA	4	8A
TE0509-1W8AN(P)T(R)	5	9	1:1.94	280μH	0.4Ω	200mA	4	8A
TE0509-2W8AN(P)T(R)	5	9	1:1.94	280μH	0.4Ω	400mA	4	8A
TE0512-1W8AN(P)T(R)	5	12	1:2.56	280μH	0.4Ω	200mA	4	8A
TE0512-2W8AN(P)T(R)	5	12	1:2.56	280μH	0.4Ω	400mA	4	8A
TE0515-1W8AN(P)T(R)	5	15	1:3.21	280μH	0.4Ω	200mA	4	8A
TE0515-2W8AN(P)T(R)	5	15	1:3.21	280μH	0.4Ω	400mA	4	8A
TE0524-1W8AN(P)T(R)	5	24	1:4.91	280μH	0.4Ω	200mA	4	8A
TE0524-2W8AN(P)T(R)	5	24	1:4.91	280μH	0.4Ω	400mA	4	8A

## 12VDC输入 / 12V DC Input

封装代号: 6A/Package code: 6A

产品型号 Product model	Input VDC	Output VDC	匝比 Turns ratio	初级电感量-LP Primary Inductance (+/-20%) @1kHz, 1V	初级电阻-RDC Primary D.C. Resistance (Max)	峰值电流-IPK Peak current (Max)	绕组 winding	封装 packaging
TE1203-1W6AN(P)T(R)	12	3.3	1:0.29	1.5mH	1.5Ω	84mA	4	6A
TE1203-2W6AN(P)T(R)	12	3.3	1:0.29	1.5mH	1.5Ω	167mA	4	6A
TE1205-1W6AN(P)T(R)	12	5	1:0.47	1.5mH	1.5Ω	84mA	4	6A
TE1205-2W6AN(P)T(R)	12	5	1:0.47	1.5mH	1.5Ω	167mA	4	6A
TE1209-1W6AN(P)T(R)	12	9	1:0.82	1.5mH	1.5Ω	84mA	4	6A
TE1209-2W6AN(P)T(R)	12	9	1:0.82	1.5mH	1.5Ω	167mA	4	6A
TE1212-1W6AN(P)T(R)	12	12	1:1.06	1.5mH	1.5Ω	84mA	4	6A
TE1212-2W6AN(P)T(R)	12	12	1:1.06	1.5mH	1.5Ω	167mA	4	6A
TE1215-1W6AN(P)T(R)	12	15	1:1.32	1.5mH	1.5Ω	84mA	4	6A
TE1215-2W6AN(P)T(R)	12	15	1:1.32	1.5mH	1.5Ω	167mA	4	6A
TE1224-1W6AN(P)T(R)	12	24	1:2.06	280μH	0.4Ω	84mA	4	6A
TE1224-2W6AN(P)T(R)	12	24	1:2.06	280μH	0.4Ω	167mA	4	6A

封装代号: 6B/Package code: 6B

产品型号 Product model	Input VDC	Output VDC	匝比 Turns ratio	初级电感量-LP Primary Inductance (+/-20%) @1kHz, 1V	初级电阻-RDC Primary D.C. Resistance (Max)	峰值电流-IPK Peak current (Max)	绕组 winding	封装 packaging
TE1203-1W6BN(P)T(R)	12	3.3	1:0.29	1.5mH	1.5Ω	84mA	4	6B
TE1203-2W6BN(P)T(R)	12	3.3	1:0.29	1.5mH	1.5Ω	167mA	4	6B
TE1205-1W6BN(P)T(R)	12	5	1:0.47	1.5mH	1.5Ω	84mA	4	6B
TE1205-2W6BN(P)T(R)	12	5	1:0.47	1.5mH	1.5Ω	167mA	4	6B
TE1209-1W6BN(P)T(R)	12	9	1:0.82	1.5mH	1.5Ω	84mA	4	6B
TE1209-2W6BN(P)T(R)	12	9	1:0.82	1.5mH	1.5Ω	167mA	4	6B
TE1212-1W6BN(P)T(R)	12	12	1:1.06	1.5mH	1.5Ω	84mA	4	6B
TE1212-2W6BN(P)T(R)	12	12	1:1.06	1.5mH	1.5Ω	167mA	4	6B
TE1215-1W6BN(P)T(R)	12	15	1:1.32	1.5mH	1.5Ω	84mA	4	6B
TE1215-2W6BN(P)T(R)	12	15	1:1.32	1.5mH	1.5Ω	167mA	4	6B
TE1224-1W6BN(P)T(R)	12	24	1:2.06	280μH	0.4Ω	84mA	4	6B
TE1224-2W6BN(P)T(R)	12	24	1:2.06	280μH	0.4Ω	167mA	4	6B

封装代号: 6C/Package code: 6C

产品型号 Product model	Input VDC	Output VDC	匝比 Turns ratio	初级电感量-LP Primary Inductance (+/-20%) @1kHz, 1V	初级电阻-RDC Primary D.C. Resistance (Max)	峰值电流-IPK Peak current (Max)	绕组 winding	封装 packaging
TE1203-1W6CN(P)T(R)	12	3.3	1:0.29	1.5mH	1.5Ω	84mA	4	6C
TE1203-2W6CN(P)T(R)	12	3.3	1:0.29	1.5mH	1.5Ω	167mA	4	6C
TE1205-1W6CN(P)T(R)	12	5	1:0.47	1.5mH	1.5Ω	84mA	4	6C
TE1205-2W6CN(P)T(R)	12	5	1:0.47	1.5mH	1.5Ω	167mA	4	6C
TE1209-1W6CN(P)T(R)	12	9	1:0.82	1.5mH	1.5Ω	84mA	4	6C
TE1209-2W6CN(P)T(R)	12	9	1:0.82	1.5mH	1.5Ω	167mA	4	6C
TE1212-1W6CN(P)T(R)	12	12	1:1.06	1.5mH	1.5Ω	84mA	4	6C
TE1212-2W6CN(P)T(R)	12	12	1:1.06	1.5mH	1.5Ω	167mA	4	6C
TE1215-1W6CN(P)T(R)	12	15	1:1.32	1.5mH	1.5Ω	84mA	4	6C
TE1215-2W6CN(P)T(R)	12	15	1:1.32	1.5mH	1.5Ω	167mA	4	6C
TE1224-1W6CN(P)T(R)	12	24	1:2.06	280μH	0.4Ω	84mA	4	6C
TE1224-2W6CN(P)T(R)	12	24	1:2.06	280μH	0.4Ω	167mA	4	6C

封装代号: 6D/Package code: 6D

产品型号 Product model	Input VDC	Output VDC	匝比 Turns ratio	初级电感量-LP Primary Inductance (+/-20%) @1kHz, 1V	初级电阻-RDC Primary D.C. Resistance (Max)	峰值电流-IPK Peak current (Max)	绕组 winding	封装 packaging
TE1203-1W6DN(P)T(R)	12	3.3	1:0.29	1.5mH	1.5Ω	84mA	4	6D
TE1203-2W6DN(P)T(R)	12	3.3	1:0.29	1.5mH	1.5Ω	167mA	4	6D
TE1205-1W6DN(P)T(R)	12	5	1:0.47	1.5mH	1.5Ω	84mA	4	6D
TE1205-2W6DN(P)T(R)	12	5	1:0.47	1.5mH	1.5Ω	167mA	4	6D
TE1209-1W6DN(P)T(R)	12	9	1:0.82	1.5mH	1.5Ω	84mA	4	6D
TE1209-2W6DN(P)T(R)	12	9	1:0.82	1.5mH	1.5Ω	167mA	4	6D
TE1212-1W6DN(P)T(R)	12	12	1:1.06	1.5mH	1.5Ω	84mA	4	6D
TE1212-2W6DN(P)T(R)	12	12	1:1.06	1.5mH	1.5Ω	167mA	4	6D
TE1215-1W6DN(P)T(R)	12	15	1:1.32	1.5mH	1.5Ω	84mA	4	6D
TE1215-2W6DN(P)T(R)	12	15	1:1.32	1.5mH	1.5Ω	167mA	4	6D
TE1224-1W6DN(P)T(R)	12	24	1:2.06	280μH	0.4Ω	84mA	4	6D
TE1224-2W6DN(P)T(R)	12	24	1:2.06	280μH	0.4Ω	167mA	4	6D

封装代号: 6E/Package code: 6E

产品型号 Product model	Input VDC	Output VDC	匝比 Turns ratio	初级电感量-LP Primary Inductance (+/-20%) @1kHz, 1V	初级电阻-RDC Primary D.C. Resistance (Max)	峰值电流-IPK Peak current (Max)	绕组 winding	封装 packaging
TE1203-1W6EN(P)T(R)	12	3.3	1:0.29	1.5mH	1.5Ω	84mA	4	6E
TE1203-2W6EN(P)T(R)	12	3.3	1:0.29	1.5mH	1.5Ω	167mA	4	6E
TE1205-1W6EN(P)T(R)	12	5	1:0.47	1.5mH	1.5Ω	84mA	4	6E
TE1205-2W6EN(P)T(R)	12	5	1:0.47	1.5mH	1.5Ω	167mA	4	6E
TE1209-1W6EN(P)T(R)	12	9	1:0.82	1.5mH	1.5Ω	84mA	4	6E
TE1209-2W6EN(P)T(R)	12	9	1:0.82	1.5mH	1.5Ω	167mA	4	6E
TE1212-1W6EN(P)T(R)	12	12	1:1.06	1.5mH	1.5Ω	84mA	4	6E
TE1212-2W6EN(P)T(R)	12	12	1:1.06	1.5mH	1.5Ω	167mA	4	6E
TE1215-1W6EN(P)T(R)	12	15	1:1.32	1.5mH	1.5Ω	84mA	4	6E
TE1215-2W6EN(P)T(R)	12	15	1:1.32	1.5mH	1.5Ω	167mA	4	6E
TE1224-1W6EN(P)T(R)	12	24	1:2.06	280μH	0.4Ω	84mA	4	6E
TE1224-2W6EN(P)T(R)	12	24	1:2.06	280μH	0.4Ω	167mA	4	6E

封装代号: 8A/Package code: 8A

产品型号 Product model	Input VDC	Output VDC	匝比 Turns ratio	初级电感量-LP Primary Inductance (+/-20%) @1kHz, 1V	初级电阻-RDC Primary D.C. Resistance (Max)	峰值电流-IPK Peak current (Max)	绕组 winding	封装 packaging
TE1203-1W8AN(P)T(R)	12	3.3	1:0.29	1.5mH	1.5Ω	84mA	4	8A
TE1203-2W8AN(P)T(R)	12	3.3	1:0.29	1.5mH	1.5Ω	167mA	4	8A
TE1205-1W8AN(P)T(R)	12	5	1:0.47	1.5mH	1.5Ω	84mA	4	8A
TE1205-2W8AN(P)T(R)	12	5	1:0.47	1.5mH	1.5Ω	167mA	4	8A
TE1209-1W8AN(P)T(R)	12	9	1:0.82	1.5mH	1.5Ω	84mA	4	8A
TE1209-2W8AN(P)T(R)	12	9	1:0.82	1.5mH	1.5Ω	167mA	4	8A
TE1212-1W8AN(P)T(R)	12	12	1:1.06	1.5mH	1.5Ω	84mA	4	8A
TE1212-2W8AN(P)T(R)	12	12	1:1.06	1.5mH	1.5Ω	167mA	4	8A
TE1215-1W8AN(P)T(R)	12	15	1:1.32	1.5mH	1.5Ω	84mA	4	8A
TE1215-2W8AN(P)T(R)	12	15	1:1.32	1.5mH	1.5Ω	167mA	4	8A
TE1224-1W8AN(P)T(R)	12	24	1:2.06	280μH	0.4Ω	84mA	4	8A
TE1224-2W8AN(P)T(R)	12	24	1:2.06	280μH	0.4Ω	167mA	4	8A

## 24VDC输入 / 24V DC Input

封装代号: 6A/Package code: 6A

产品型号 Product model	Input VDC	Output VDC	匝比 Turns ratio	初级电感量-LP Primary Inductance (+/-20%) @1kHz, 1V	初级电阻-RDC Primary D.C. Resistance (Max)	峰值电流-IPK Peak current (Max)	绕组 winding	封装 packaging
TE2403-1W6AN(P)T(R)	24	3.3	1:0.16	2.5mH	3.5Ω	42mA	4	6A
TE2403-2W6AN(P)T(R)	24	3.3	1:0.16	2.5mH	3.5Ω	84mA	4	6A
TE2405-1W6AN(P)T(R)	24	5	1:0.24	2.5mH	3.5Ω	42mA	4	6A
TE2405-2W6AN(P)T(R)	24	5	1:0.24	2.5mH	3.5Ω	84mA	4	6A
TE2409-1W6AN(P)T(R)	24	9	1:0.40	2.5mH	3.5Ω	42mA	4	6A
TE2409-2W6AN(P)T(R)	24	9	1:0.40	2.5mH	3.5Ω	84mA	4	6A
TE2412-1W6AN(P)T(R)	24	12	1:0.54	2.5mH	3.5Ω	42mA	4	6A
TE2412-2W6AN(P)T(R)	24	12	1:0.54	2.5mH	3.5Ω	84mA	4	6A
TE2415-1W6AN(P)T(R)	24	15	1:0.66	2.5mH	3.5Ω	42mA	4	6A
TE2415-2W6AN(P)T(R)	24	15	1:0.66	2.5mH	3.5Ω	84mA	4	6A
TE2424-1W6AN(P)T(R)	24	24	1:1.04	2.5mH	3.5Ω	42mA	4	6A
TE2424-2W6AN(P)T(R)	24	24	1:1.04	2.5mH	3.5Ω	84mA	4	6A

封装代号: 6B/Package code: 6B

产品型号 Product model	Input VDC	Output VDC	匝比 Turns ratio	初级电感量-LP Primary Inductance (+/-20%) @1kHz, 1V	初级电阻-RDC Primary D.C. Resistance (Max)	峰值电流-IPK Peak current (Max)	绕组 winding	封装 packaging
TE2403-1W6BN(P)T(R)	24	3.3	1:0.16	2.5mH	3.5Ω	42mA	4	6B
TE2403-2W6BN(P)T(R)	24	3.3	1:0.16	2.5mH	3.5Ω	84mA	4	6B
TE2405-1W6BN(P)T(R)	24	5	1:0.24	2.5mH	3.5Ω	42mA	4	6B
TE2405-2W6BN(P)T(R)	24	5	1:0.24	2.5mH	3.5Ω	84mA	4	6B
TE2409-1W6BN(P)T(R)	24	9	1:0.40	2.5mH	3.5Ω	42mA	4	6B
TE2409-2W6BN(P)T(R)	24	9	1:0.40	2.5mH	3.5Ω	84mA	4	6B
TE2412-1W6BN(P)T(R)	24	12	1:0.54	2.5mH	3.5Ω	42mA	4	6B
TE2412-2W6BN(P)T(R)	24	12	1:0.54	2.5mH	3.5Ω	84mA	4	6B
TE2415-1W6BN(P)T(R)	24	15	1:0.66	2.5mH	3.5Ω	42mA	4	6B
TE2415-2W6BN(P)T(R)	24	15	1:0.66	2.5mH	3.5Ω	84mA	4	6B
TE2424-1W6BN(P)T(R)	24	24	1:1.04	2.5mH	3.5Ω	42mA	4	6B
TE2424-2W6BN(P)T(R)	24	24	1:1.04	2.5mH	3.5Ω	84mA	4	6B

封装代号: 6C/Package code: 6C

产品型号 Product model	Input VDC	Output VDC	匝比 Turns ratio	初级电感量-LP Primary Inductance (+/-20%) @1kHz, 1V	初级电阻-RDC Primary D.C. Resistance (Max)	峰值电流-IPK Peak current (Max)	绕组 winding	封装 packaging
TE2403-1W6CN(P)T(R)	24	3.3	1:0.16	2.5mH	3.5Ω	42mA	4	6C
TE2403-2W6CN(P)T(R)	24	3.3	1:0.16	2.5mH	3.5Ω	84mA	4	6C
TE2405-1W6CN(P)T(R)	24	5	1:0.24	2.5mH	3.5Ω	42mA	4	6C
TE2405-2W6CN(P)T(R)	24	5	1:0.24	2.5mH	3.5Ω	84mA	4	6C
TE2409-1W6CN(P)T(R)	24	9	1:0.40	2.5mH	3.5Ω	42mA	4	6C
TE2409-2W6CN(P)T(R)	24	9	1:0.40	2.5mH	3.5Ω	84mA	4	6C
TE2412-1W6CN(P)T(R)	24	12	1:0.54	2.5mH	3.5Ω	42mA	4	6C
TE2412-2W6CN(P)T(R)	24	12	1:0.54	2.5mH	3.5Ω	84mA	4	6C
TE2415-1W6CN(P)T(R)	24	15	1:0.66	2.5mH	3.5Ω	42mA	4	6C
TE2415-2W6CN(P)T(R)	24	15	1:0.66	2.5mH	3.5Ω	84mA	4	6C
TE2424-1W6CN(P)T(R)	24	24	1:1.04	2.5mH	3.5Ω	42mA	4	6C
TE2424-2W6CN(P)T(R)	24	24	1:1.04	2.5mH	3.5Ω	84mA	4	6C

封装代号: 6D/Package code: 6D

产品型号 Product model	Input VDC	Output VDC	匝比 Turns ratio	初级电感量-LP Primary Inductance (+/-20%) @1kHz, 1V	初级电阻-RDC Primary D.C. Resistance (Max)	峰值电流-IPK Peak current (Max)	绕组 winding	封装 packaging
TE2403-1W6DN(P)T(R)	24	3.3	1:0.16	2.5mH	3.5Ω	42mA	4	6D
TE2403-2W6DN(P)T(R)	24	3.3	1:0.16	2.5mH	3.5Ω	84mA	4	6D
TE2405-1W6DN(P)T(R)	24	5	1:0.24	2.5mH	3.5Ω	42mA	4	6D
TE2405-2W6DN(P)T(R)	24	5	1:0.24	2.5mH	3.5Ω	84mA	4	6D
TE2409-1W6DN(P)T(R)	24	9	1:0.40	2.5mH	3.5Ω	42mA	4	6D
TE2409-2W6DN(P)T(R)	24	9	1:0.40	2.5mH	3.5Ω	84mA	4	6D
TE2412-1W6DN(P)T(R)	24	12	1:0.54	2.5mH	3.5Ω	42mA	4	6D
TE2412-2W6DN(P)T(R)	24	12	1:0.54	2.5mH	3.5Ω	84mA	4	6D
TE2415-1W6DN(P)T(R)	24	15	1:0.66	2.5mH	3.5Ω	42mA	4	6D
TE2415-2W6DN(P)T(R)	24	15	1:0.66	2.5mH	3.5Ω	84mA	4	6D
TE2424-1W6DN(P)T(R)	24	24	1:1.04	2.5mH	3.5Ω	42mA	4	6D
TE2424-2W6DN(P)T(R)	24	24	1:1.04	2.5mH	3.5Ω	84mA	4	6D

封装代号: 6E/Package code: 6E

产品型号 Product model	Input VDC	Output VDC	匝比 Turns ratio	初级电感量-LP Primary Inductance (+/-20%) @1kHz, 1V	初级电阻-RDC Primary D.C. Resistance (Max)	峰值电流-IPK Peak current (Max)	绕组 winding	封装 packaging
TE2403-1W6EN(P)T(R)	24	3.3	1:0.16	2.5mH	3.5Ω	42mA	4	6E
TE2403-2W6EN(P)T(R)	24	3.3	1:0.16	2.5mH	3.5Ω	84mA	4	6E
TE2405-1W6EN(P)T(R)	24	5	1:0.24	2.5mH	3.5Ω	42mA	4	6E
TE2405-2W6EN(P)T(R)	24	5	1:0.24	2.5mH	3.5Ω	84mA	4	6E
TE2409-1W6EN(P)T(R)	24	9	1:0.40	2.5mH	3.5Ω	42mA	4	6E
TE2409-2W6EN(P)T(R)	24	9	1:0.40	2.5mH	3.5Ω	84mA	4	6E
TE2412-1W6EN(P)T(R)	24	12	1:0.54	2.5mH	3.5Ω	42mA	4	6E
TE2412-2W6EN(P)T(R)	24	12	1:0.54	2.5mH	3.5Ω	84mA	4	6E
TE2415-1W6EN(P)T(R)	24	15	1:0.66	2.5mH	3.5Ω	42mA	4	6E
TE2415-2W6EN(P)T(R)	24	15	1:0.66	2.5mH	3.5Ω	84mA	4	6E
TE2424-1W6EN(P)T(R)	24	24	1:1.04	2.5mH	3.5Ω	42mA	4	6E
TE2424-2W6EN(P)T(R)	24	24	1:1.04	2.5mH	3.5Ω	84mA	4	6E

封装代号: 8A/Package code: 8A

产品型号 Product model	Input VDC	Output VDC	匝比 Turns ratio	初级电感量-LP Primary Inductance (+/-20%) @1kHz, 1V	初级电阻-RDC Primary D.C. Resistance (Max)	峰值电流-IPK Peak current (Max)	绕组 winding	封装 packaging
TE2403-1W8AN(P)T(R)	24	3.3	1:0.16	2.5mH	3.5Ω	42mA	4	8A
TE2403-2W8AN(P)T(R)	24	3.3	1:0.16	2.5mH	3.5Ω	84mA	4	8A
TE2405-1W8AN(P)T(R)	24	5	1:0.24	2.5mH	3.5Ω	42mA	4	8A
TE2405-2W8AN(P)T(R)	24	5	1:0.24	2.5mH	3.5Ω	84mA	4	8A
TE2409-1W8AN(P)T(R)	24	9	1:0.40	2.5mH	3.5Ω	42mA	4	8A
TE2409-2W8AN(P)T(R)	24	9	1:0.40	2.5mH	3.5Ω	84mA	4	8A
TE2412-1W8AN(P)T(R)	24	12	1:0.54	2.5mH	3.5Ω	42mA	4	8A
TE2412-2W8AN(P)T(R)	24	12	1:0.54	2.5mH	3.5Ω	84mA	4	8A
TE2415-1W8AN(P)T(R)	24	15	1:0.66	2.5mH	3.5Ω	42mA	4	8A
TE2415-2W8AN(P)T(R)	24	15	1:0.66	2.5mH	3.5Ω	84mA	4	8A
TE2424-1W8AN(P)T(R)	24	24	1:1.04	2.5mH	3.5Ω	42mA	4	8A
TE2424-2W8AN(P)T(R)	24	24	1:1.04	2.5mH	3.5Ω	84mA	4	8A

## Circuit Design and Application/电路设计与应用

具体应用电路需要根据控制IC的参数进行确定，在设计前请与我司技术人员联系，获取正确的设计方案。

**The specific application circuit needs to be determined according to the parameters of the control IC. Before design, please contact our technical personnel to obtain the correct design scheme.**

3.3V,5V输入，6A, 6B , 6C , 6D , 6E封装接线图

Wiring diagram for 3.3V, 5V input, 6A, 6B , 6C , 6D , 6E package

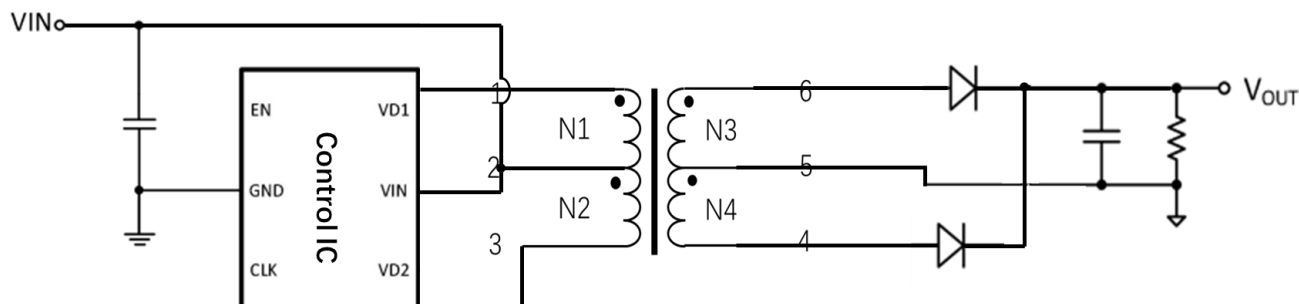

3.3V,5V输入，8A封装接线图

Wiring diagram for 3.3V, 5V input, 8A package

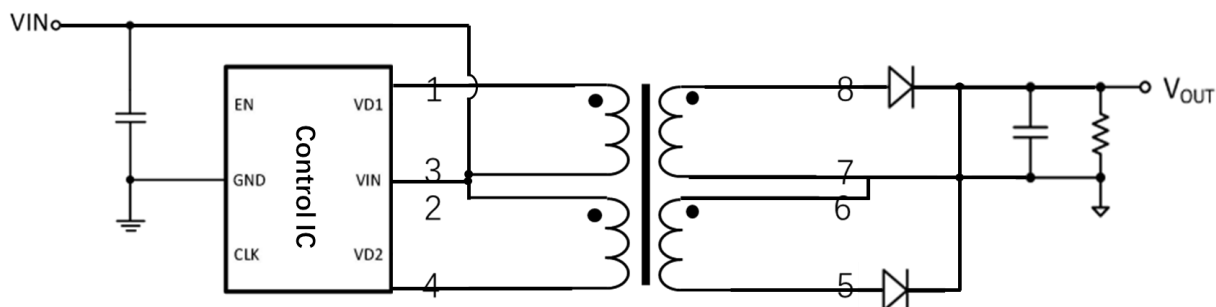

12V,24V输入，6A, 6B, 6C, 6D, 6E封装接线图

Wiring diagram for 12V, 24V input, 6A, 6B, 6C, 6D, 6E package

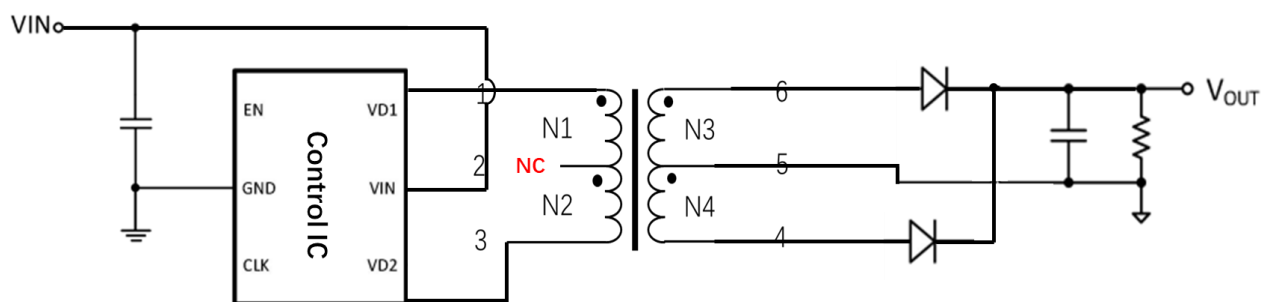

12V,24V输入，8A封装接线图

Wiring diagram for 12V, 24V input, 8A package

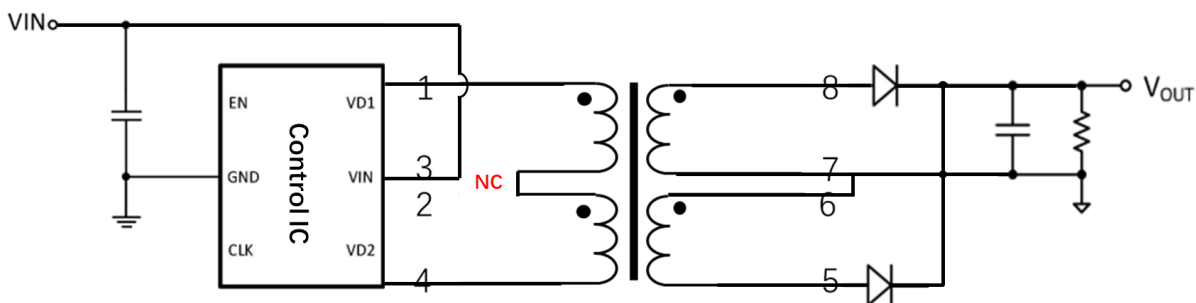

变压器第2、3脚用焊盘连接，但是不能连接到其它任何电路。

The 2nd and 3rd pins of the transformer are connected to solder pads, but they cannot be connected to any other circuits.

## General Characteristics/通用特性

Parameter/参数	Conditions/测试条件	Min.	Typ.	Max.	Units
漏感-LL Leakage Inductance	@1kHz, 1V			25	μH
绕组电容-CWW Interwinding Capacitance	@1kHz, 1V			20	pF
Isolation voltage 隔离电压	Input-output, Test time 1 minute, Leakage current less than 1 mA 输入-输出, 测试时间1分钟, 漏电流小于1 mA	3000	--	--	VDC
Insulation resistance 绝缘电阻	Input-output, Insulation voltage 500VDC 输入-输出, 绝缘电压500VDC	1000	--	--	MΩ
Working temperature 工作温度	Temperature ≥ 85 °C for derating 温度≥85°C时, 降额使用。	-40	--	+125	°C
Storage temperature 储存温度		-55	--	+155	°C
Storage humidity 储存湿度	Non condensing 无凝结	--	--	95	%RH
Housing temperature rise during operation 工作时外壳温升	Ta=25 °C, Nominal input, Full output Ta=25°C, 标称电压输入, 满载	--	15	25	°C
Soldering temperature resistance of pins 引脚耐焊接温度	The distance from the welding spot to the shell is 1.5mm, 10 seconds 焊点到壳体的距离为1.5mm, 10秒	--	--	300	°C
	REFLOW: Peak temperature Tc ≤ 235 °C, maximum time above 217 °C for 60 seconds. 回流焊: 峰值温度 Tc ≤ 235°C, 217°C以上时间最大为60s.	--	--	235	°C
Mean time between failures 【MTBF】 平均无故障时间	MIL-HDBK-217F@25°C	3500	--	--	kHours
Housing material 外壳材料	Black flame retardant and heat-resistant plastic (UL94V-0) 黑色阻燃耐热塑料 (UL94V-0)				
Overall dimensions 外形尺寸	见封装尺寸图/See package dimension drawing				
Weight 重量	1.0-1.5g(Typ.)				
Cooling mode 冷却方式	Natural air cooling 自然空冷				

**Packaging Method/包装方式**

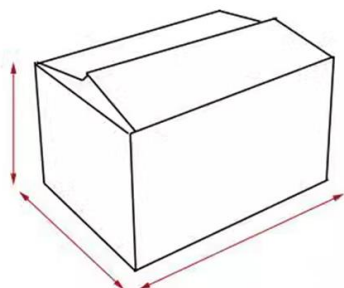
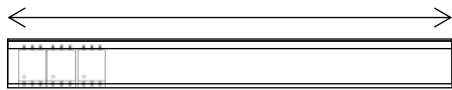

封装 Packaging	管装 Tube	卷盘包装 Reel
6A	43	1000
6B	57	1000
6C	50	1000
6D	42	1000
6E	55	1000
8A	44	1000

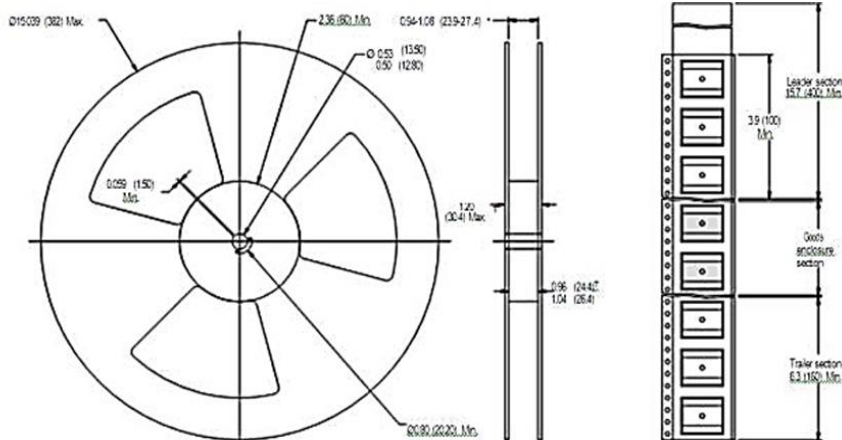

1000 Pieces/Tape & Reel

1000PCS/卷盘

**Notes & Instructions/注释和说明**

1. The operating current shall not exceed the specified range, otherwise permanent and unrecoverable damage may be caused;
2. Unless otherwise specified, the parameters in this manual are measured at 25 °C and 40%~75% humidity;
3. All index test methods are based on the company's enterprise standards.
4. The copyright and the final interpretation right of the product belong to DIGENT.

1. 工作电流不得超过规定的范围值，否则可能造成永久性和不可恢复的损坏；
2. 除非另有规定，否则本手册中的参数是在25°C、湿度40%~75%的条件下测量的；
3. 所有指标测试方法均基于本公司的企业标准；
4. 该产品的版权和最终解释权归DIGENT所有。