

BK13 Series

0.35mm Pitch, 0.6 to 2.0mm Stacking Height, 1.9mm Width, Hybrid FPC-to-Board Connector Supporting 5A

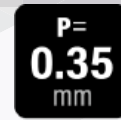

P = 0.35mm



Full Armored



High-Current

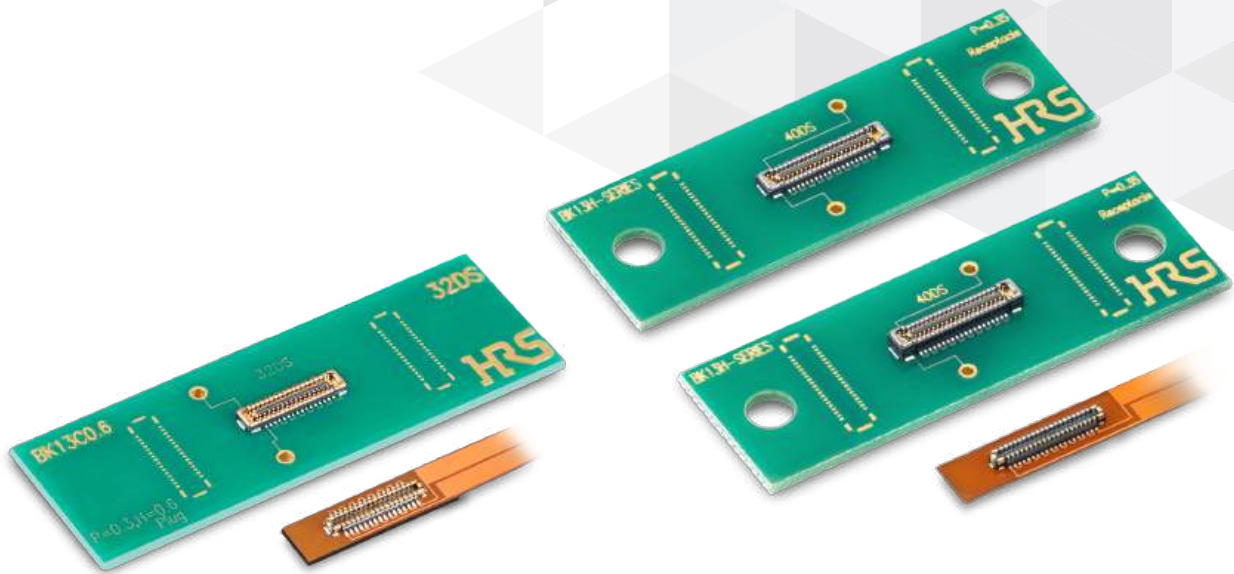

Features

1. High Power Supply Capacity and Space-saving Design

Equipped with two power contacts supporting up to 5A, the reduced number of signal contacts optimizes mounting space.

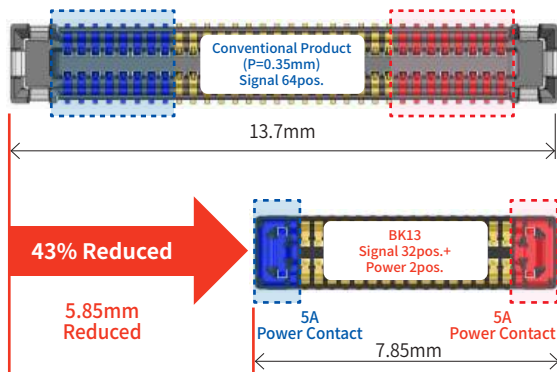

Power lines typically diverted to multiple signal contacts are concentrated into 2 power contacts (Up to 5A/line)

2. Robust Design

Fully armored guides prevent housing damage due to misalignment when mating.

<Conventional Products>

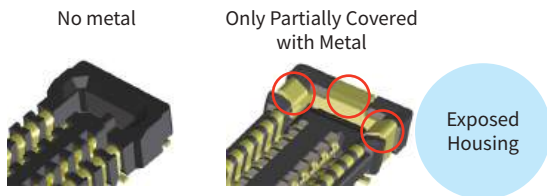

<BK13>

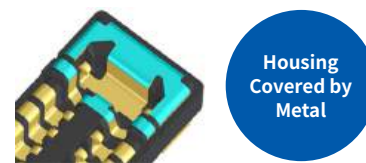

3. Enhanced PCB Peeling Strength

Both the plug and receptacle feature three soldering points per power contact, significantly improving PCB peeling strength.

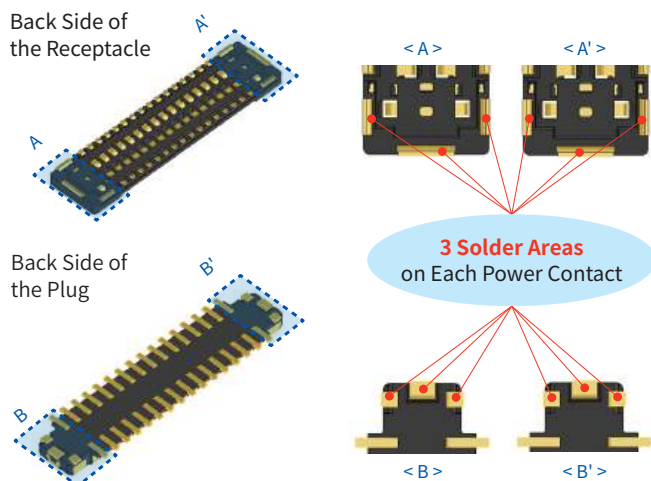

4. Wide Stacking Height Variations

The plug and receptacle combination allows flexible stacking height options, enhancing board design flexibility.

- BK13C plug mates with the BK13C receptacle.
- BK13H plug mates with the BK13H receptacle.

Product Type		BK13C	BK13H				
Stacking Height (mm)		0.6	0.8	1.0	1.3	1.5	2.0
No. of Pos.	6	○	-	-	-	-	-
	10	○	-	-	-	-	-
	12	○	-	-	-	-	-
	16	○	-	-	△	-	-
	24	○	-	△	-	-	-
	30	-	-	△	-	○	-
	32	○	-	-	-	-	-
	34	-	-	△	-	-	-
	40	○	-	○	-	○	-
	50	○	-	-	-	-	-
	60	○	-	△	-	○	-

○ = Mass Production, △ = Under Development

5. High Contact Reliability

The two-point contact design for both power and signal contacts ensures high reliability.

6. Superior Mating

Wide self-alignment range with metal guides improves the mating process.

BK13C : $\pm 0.3\text{mm}$ (pitch direction), $\pm 0.22\text{mm}$ (width direction)

BK13H : $\pm 0.345\text{mm}$ (pitch direction), $\pm 0.23\text{mm}$ (width direction)

Additionally, a clear tactile click from the unique locking contact design ensures complete mating.

7. Halogen-Free

All materials and substances used to produce this product comply with Halogen-free standards.

*As defined by IEC 61249-2-21

Br : 900ppm max., Cl : 900ppm max., Br+Cl : 1,500ppm max.

Product Specifications

Rated Current (Note1)	BK13C	BK13H	Operating Temperature (Note 2)	-55 to +85°C
	Signal Contact : 0.3A Power Contact : 5A	Signal Contact : 0.2A Power Contact : 5A	Operating Humidity Range (Note 3)	20 to 80%
Rated Voltage	50V AC/DC		Storage Temperature (Note 4)	-10 to +60°C
			Storage Humidity Range (Note 3)(Note 4)	40 to 70%

Items	Specifications	Conditions
Contact Resistance	Signal Contact : 50mΩ Max. Power Contact : 15mΩ Max.	Measured at 20mV AC, 1kHz, 1mA
Insulation Resistance	50MΩ Min.	Measured at 100V DC
Withstanding Voltage	No flashover or insulation breakdown	150V AC for 1 min.
Mating Durability	Signal Contact : 50mΩ Max. Power Contact : 15mΩ Max. No damage, crack or looseness of parts	30 mating cycles
Vibration Resistance	No electrical discontinuity of 1μs or more No damage, crack or looseness of parts	Frequency : 10 to 55Hz, single amplitude 0.75mm, 10 cycles in each of 3 axis directions for 5 minutes/cycle
Shock Resistance	No electrical discontinuity of 1μs or more No damage, crack or looseness of parts	Acceleration : 490m/s ² , duration of pulse: 11ms at 3 times for 3 directions.
Humidity Resistance	Signal Contact : 50mΩ Max. Power Contact : 15mΩ Max. Insulation Resistance: 25MΩ Min. No damage, crack or looseness of parts	96 hours at temperature of 40±2°C and humidity range from 90 to 95%
Temperature Cycle	Signal Contact : 50mΩ Max. Power Contact : 15mΩ Max. Insulation Resistance : 50MΩ Min. No damage, crack or looseness of parts	-55°C for 30min. → +85°C for 30 min. for 5 Cycles . (Stabilizing Time In Chamber : Within 2 to 3 min.)
Sulfur Dioxide	Signal Contact : 50mΩ Max. Power Contact : 15mΩ Max. No damage, crack or looseness of parts	Exposed in 25 PPM for 96h at 25°C, 75±5%RH. (Test standard : JIS C 60068)

Note 1 : The total current capacity for the signal contacts is 12A Max. for BK13C, and 8A Max. for BK13H.

Note 2 : Includes temperature rise caused by current flow.

Note 3 : Range identified without condensation.

Note 4 : The term "storage" refers to long-term-storage of unused items before they are mounted on the PCB.

Operating temperature / humidity range applies to the product in a temporary storage state such as non-powered after mounting on the PCB during transportation, etc.

Materials / Finish

Part	Component	Material	Finish	Remarks
Plug Receptacle	Insulator	LCP	Black	UL94V-0
	Signal Contact	Copper Alloy	Gold Plated over Nickel Underplating	-
	Power Contact	Copper Alloy	Gold Plated over Nickel Underplating	-

Product Number Structure

Refer to the chart below when determining the product specifications from the product number.
Please select from the product numbers listed in this catalog when placing orders.

● BK13C Plug/Receptacle

BK13 **C** **06** - **32** **DP** / **2** - **0.35** **V** **(800)**

① ② ③ ④ ⑤ ⑥ ⑦ ⑧ ⑨

① Series Name	BK13	⑥ Number of Power Contacts	2pos.
② Configuration	C : Standard Type	⑦ Contact Pitch	0.35mm
③ Stacking Height	0.6mm	⑧ Terminal Type	V : Straight SMT
④ Number of Signal Contacts	6, 10, 12, 16, 24, 32, 40, 50, 60pos.	⑨ Packaging	(800) : Standard, Embossed tape packaging (20,000pcs per reel)
⑤ Connector Type	DP : Double-row Plug DS : Double-row Receptacle		(895) : Embossed tape packaging (1,000pcs per reel) (For trial production)

● BK13H Plug/Receptacle

BK13 **H** - **40** **DP** / **2** - **0.35** **V** **05** **(800)**

① ② ③ ④ ⑤ ⑥ ⑦ ⑧ ⑨

① Series Name	BK13	⑥ Contact Pitch	0.35mm
② Configuration	H : Height Variation Type (0.8, 1.0, 1.3, 1.5, 2.0mm)	⑦ Terminal Type	V : Straight SMT
③ Number of Signal Contacts	30, 40, 60pos.	⑧ Height Type	Stacking Height (mm) : Numerical value on the plug side + Numerical value on the receptacle side
④ Connector Type	DP : Double-row Plug DS : Double-row Receptacle	⑨ Packaging	(800) : Standard, [⑧ =05] : Embossed tape packaging (20,000pcs per reel) [⑧ =10] : Embossed tape packaging (14,000pcs per reel)
⑤ Number of Power Contacts	2pos.		(895) : Embossed tape packaging (1,000pcs per reel) (For trial production)

Mating Combinations

● Stacking Height

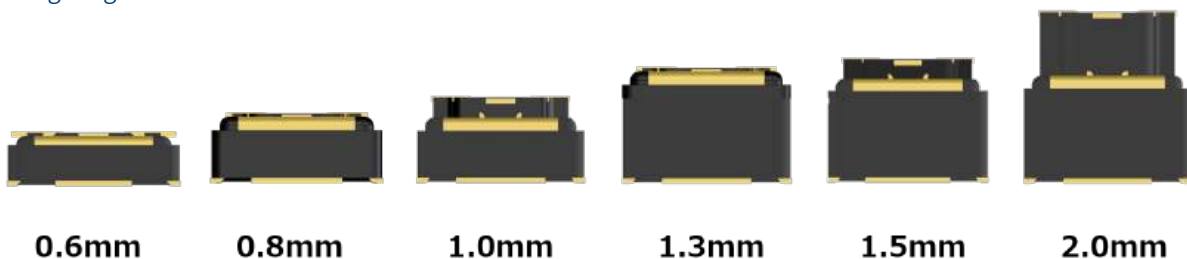

Unit : mm

Receptacle/Plug	BK13C06-##DP/2-0.35V	BK13H-##DP/2-0.35V03	BK13H-##DP/2-0.35V05	BK13H-##DP/2-0.35V10
BK13C06-##DS/2-0.35V	0.6	-	-	-
BK13H-##DS/2-0.35V05	-	0.8	1.0	2.0
BK13H-##DS/2-0.35V10	-	1.3	1.5	2.0

Note 1 : 「##」 represents the number of signal contacts.

Note 2 : Stacking height : 0.8, 1.3 and 2.0mm products are under development. Please contact Hirose for detailed information about pin variations.

BK13C Plug (Stacking Height : 0.6mm)

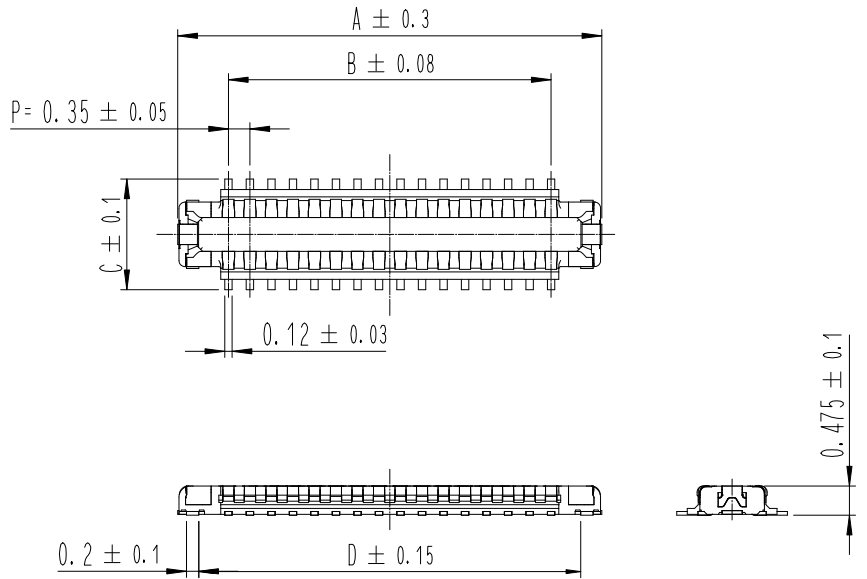

Unit : mm

Part No.	HRS No.	No. of Pos.		A	B	C	D	Purchase Unit
		Signal Contact	Power Contact					
BK13C06-6DP/2-0.35V(800) (Note 1)	CL0480-0798-0-00	6	2	2.35	0.70	1.60	1.665	20,000pcs per reel
BK13C06-10DP/2-0.35V(800)	CL0480-0719-0-00	10	2	3.05	1.40	1.60	2.365	
BK13C06-12DP/2-0.35V(800)	CL0480-0895-0-00	12	2	3.40	1.75	1.80	2.715	
BK13C06-16DP/2-0.35V(800)	CL0480-0721-0-00	16	2	4.10	2.45	1.80	3.415	
BK13C06-24DP/2-0.35V(800)	CL0673-0142-0-00	24	2	5.50	3.85	1.80	4.815	
BK13C06-32DP/2-0.35V(800)	CL0480-0663-0-00	32	2	6.90	5.25	1.80	6.215	
BK13C06-40DP/2-0.35V(800)	CL0480-0665-0-00	40	2	8.30	6.65	1.80	7.615	
BK13C06-50DP/2-0.35V(800)	CL0480-0725-0-00	50	2	10.05	8.40	1.80	9.365	
BK13C06-60DP/2-0.35V(800)	CL0480-0727-0-00	60	2	11.80	10.15	1.80	11.115	

Part No.	HRS No.	No. of Pos.		A	B	C	D	Purchase Unit
		Signal Contact	Power Contact					
BK13C06-6DP/2-0.35V(895) (Note 1)	CL0480-0798-0-95	6	2	2.35	0.70	1.60	1.665	1,000pcs per reel
BK13C06-10DP/2-0.35V(895)	CL0480-0719-0-95	10	2	3.05	1.40	1.60	2.365	
BK13C06-12DP/2-0.35V(895)	CL0480-0895-0-95	12	2	3.40	1.75	1.80	2.715	
BK13C06-16DP/2-0.35V(895)	CL0480-0721-0-95	16	2	4.10	2.45	1.80	3.415	
BK13C06-24DP/2-0.35V(895)	CL0673-0144-0-00	24	2	5.50	3.85	1.80	4.815	
BK13C06-32DP/2-0.35V(895)	CL0480-0663-0-95	32	2	6.90	5.25	1.80	6.215	
BK13C06-40DP/2-0.35V(895)	CL0480-0665-0-95	40	2	8.30	6.65	1.80	7.615	
BK13C06-50DP/2-0.35V(895)	CL0480-0725-0-95	50	2	10.05	8.40	1.80	9.365	
BK13C06-60DP/2-0.35V(895)	CL0480-0727-0-95	60	2	11.80	10.15	1.80	11.115	

Note 1 : The power contacts of BK13C06-6DP/2-0.35V have an embossed design.

Note 2 : This connector has no polarity.

● Recommended PCB Layout

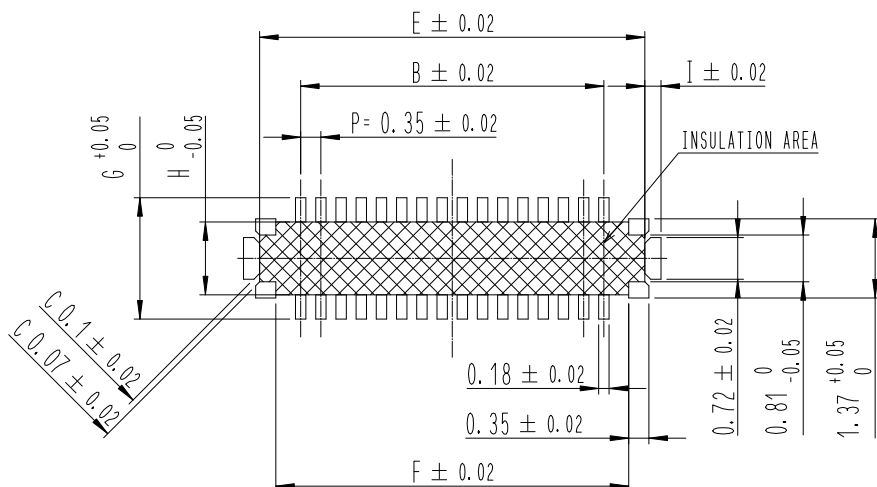

● Recommended Metal Mask Dimensions
(Mask Thickness : 0.08mm)

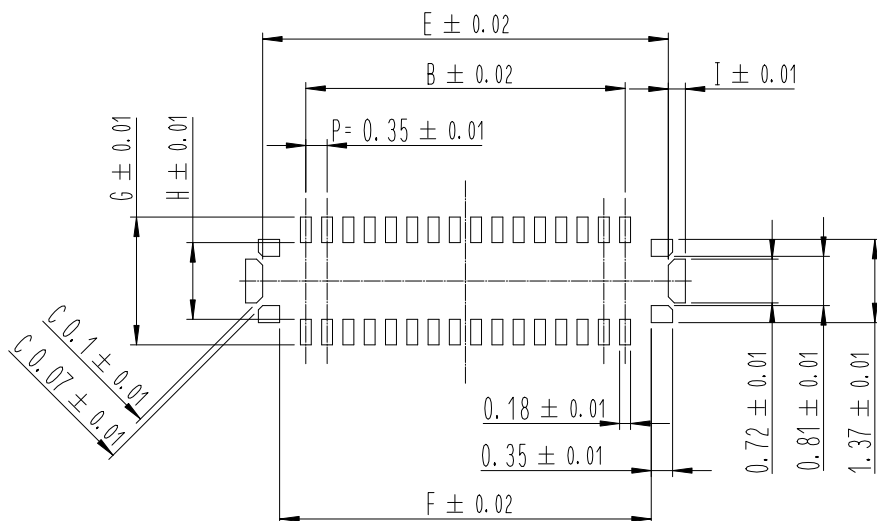

Unit : mm

Part No.	No. of Pos.		B	E	F	G	H	I
	Signal Contact	Power Contact						
BK13C06-6DP/2-0.35V(8##)	6	2	0.70	2.12	1.56	1.8	1.06	0.23
BK13C06-10DP/2-0.35V(8##)	10	2	1.40	2.82	2.26	1.8	1.06	0.23
BK13C06-12DP/2-0.35V(8##)	12	2	1.75	3.17	2.61	2.1	1.26	0.28
BK13C06-16DP/2-0.35V(8##)	16	2	2.45	3.87	3.31	2.1	1.26	0.28
BK13C06-24DP/2-0.35V(8##)	24	2	3.85	5.27	4.71	2.1	1.26	0.28
BK13C06-32DP/2-0.35V(8##)	32	2	5.25	6.67	6.11	2.1	1.26	0.28
BK13C06-40DP/2-0.35V(8##)	40	2	6.65	8.07	7.51	2.1	1.26	0.28
BK13C06-50DP/2-0.35V(8##)	50	2	8.40	9.82	9.26	2.1	1.26	0.28
BK13C06-60DP/2-0.35V(8##)	60	2	10.15	11.57	11.01	2.1	1.26	0.28

Note : This connector has no polarity.

BK13C Receptacle (Stacking Height : 0.6mm)

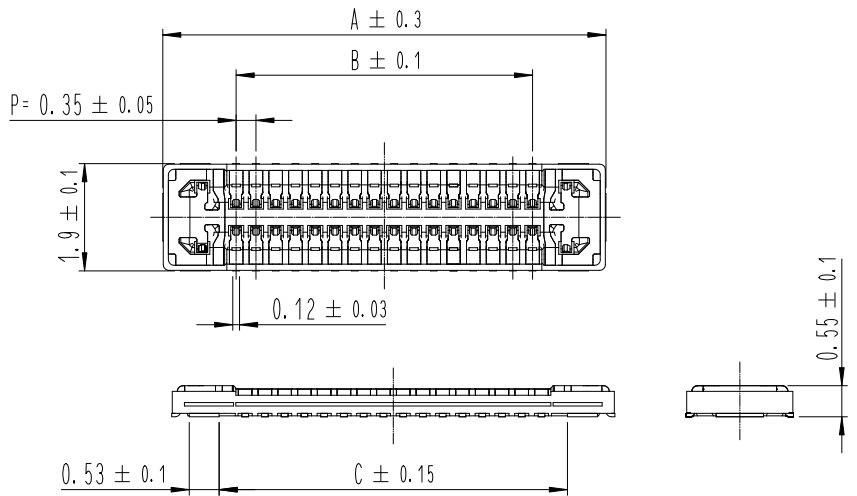
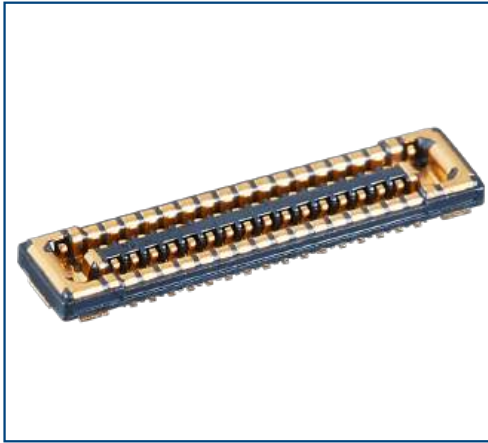

Unit : mm

Part No.	HRS No.	No. of Pos.		A	B	C	Purchase Unit
		Signal Contact	Power Contact				
BK13C06-6DS/2-0.35V(800) (Note 1, 2)	CL0480-0799-0-00	6	2	3.30	0.70	1.62	20,000pcs per reel
BK13C06-10DS/2-0.35V(800) (Note 2)	CL0480-0720-0-00	10	2	4.00	1.40	2.32	
BK13C06-12DS/2-0.35V(800)	CL0480-0896-0-00	12	2	4.35	1.75	2.67	
BK13C06-16DS/2-0.35V(800)	CL0480-0722-0-00	16	2	5.05	2.45	3.37	
BK13C06-24DS/2-0.35V(800)	CL0673-0143-0-00	24	2	6.45	3.85	4.77	
BK13C06-32DS/2-0.35V(800)	CL0480-0664-0-00	32	2	7.85	5.25	6.17	
BK13C06-40DS/2-0.35V(800)	CL0480-0666-0-00	40	2	9.25	6.65	7.57	
BK13C06-50DS/2-0.35V(800)	CL0480-0726-0-00	50	2	11.00	8.40	9.32	
BK13C06-60DS/2-0.35V(800)	CL0480-0728-0-00	60	2	12.75	10.15	11.07	

Part No.	HRS No.	No. of Pos.		A	B	C	Purchase Unit
		Signal Contact	Power Contact				
BK13C06-6DS/2-0.35V(895) (Note 1, 2)	CL0480-0799-0-95	6	2	3.30	0.70	1.62	1,000pcs per reel
BK13C06-10DS/2-0.35V(895) (Note 2)	CL0480-0720-0-95	10	2	4.00	1.40	2.32	
BK13C06-12DS/2-0.35V(895)	CL0480-0896-0-95	12	2	4.35	1.75	2.67	
BK13C06-16DS/2-0.35V(895)	CL0480-0722-0-95	16	2	5.05	2.45	3.37	
BK13C06-24DS/2-0.35V(895)	CL0673-0145-0-00	24	2	6.45	3.85	4.77	
BK13C06-32DS/2-0.35V(895)	CL0480-0664-0-95	32	2	7.85	5.25	6.17	
BK13C06-40DS/2-0.35V(895)	CL0480-0666-0-95	40	2	9.25	6.65	7.57	
BK13C06-50DS/2-0.35V(895)	CL0480-0726-0-95	50	2	11.00	8.40	9.32	
BK13C06-60DS/2-0.35V(895)	CL0480-0728-0-95	60	2	12.75	10.15	11.07	

Note 1 : The power contacts of BK13C06-6DS/2-0.35V have a dimpled design.

Note 2 : BK13C06-6DS/2-0.35V and BK13C06-10DS/2-0.35V have a metal reinforcement in the center of the product.

Note 3 : This connector has no polarity.

● Recommended PCB Layout

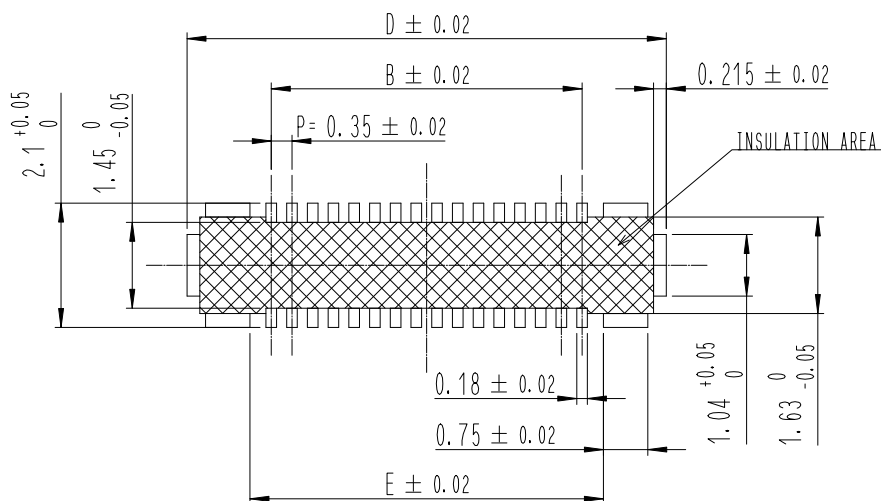

● Recommended Metal Mask Dimensions
(Mask Thickness : 0.08mm)

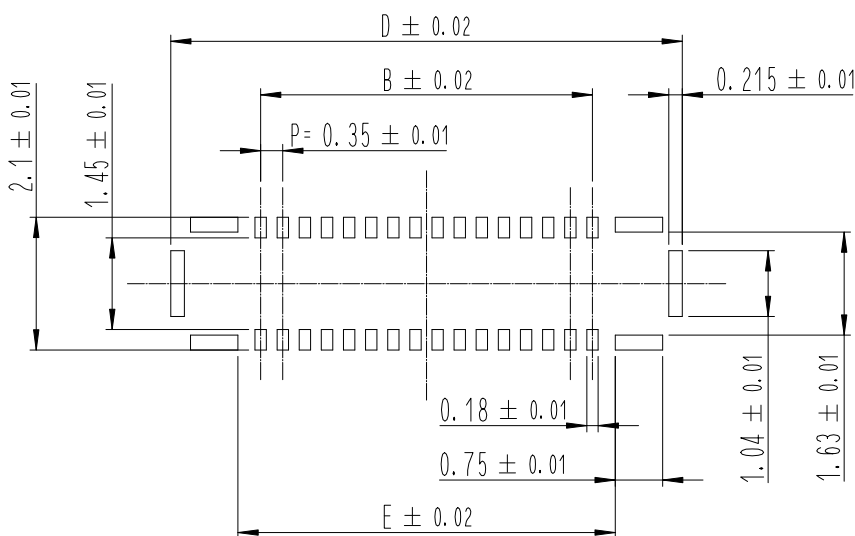

Unit : mm

Part No.	No. of Pos.		B	D	E
	Signal Contact	Power Contact			
BK13C06-6DS/2-0.35V(8##)	6	2	0.70	3.545	1.42
BK13C06-10DS/2-0.35V(8##)	10	2	1.40	4.245	2.12
BK13C06-12DS/2-0.35V(8##)	12	2	1.75	4.595	2.47
BK13C06-16DS/2-0.35V(8##)	16	2	2.45	5.295	3.17
BK13C06-24DS/2-0.35V(8##)	24	2	3.85	6.695	4.57
BK13C06-32DS/2-0.35V(8##)	32	2	5.25	8.095	5.97
BK13C06-40DS/2-0.35V(8##)	40	2	6.65	9.495	7.37
BK13C06-50DS/2-0.35V(8##)	50	2	8.40	11.245	9.12
BK13C06-60DS/2-0.35V(8##)	60	2	10.15	12.995	10.87

Note : This connector has no polarity.

BK13H Plug (Stacking Height : 1.0, 1.5mm)

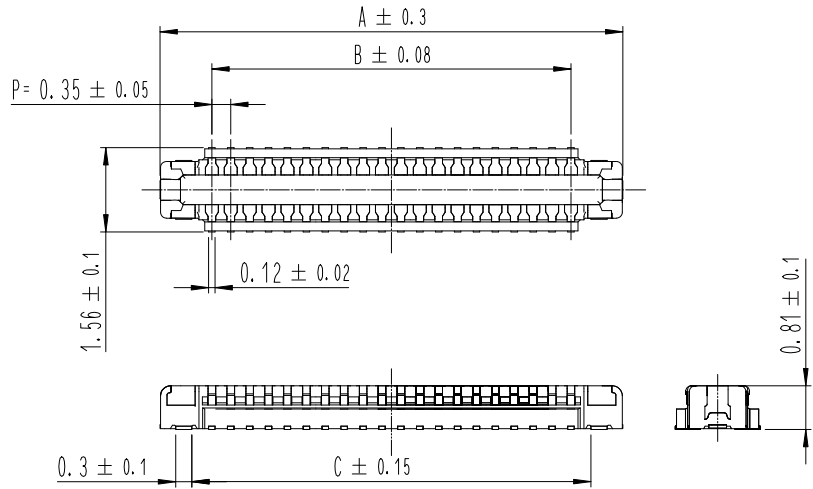

Recommended PCB Layout

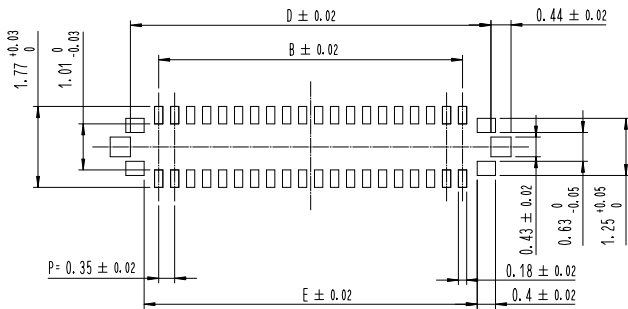

Recommended Metal Mask Dimensions (Mask Thickness : 0.08mm)

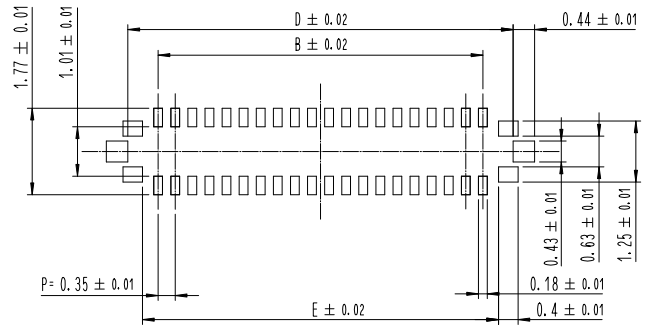

Unit : mm

Part No.	HRS No.	No. of Pos.		A	B	C	D	E	Purchase Unit	
		Signal Contact	Power Contact						## : 00	## : 95
BK13H-30DP/2-0.35V05(8##)	CL0480-1113-0-##	30	2	6.82	4.9	5.64	6.14	5.54	20,000pcs per reel	1,000pcs per reel
BK13H-40DP/2-0.35V05(8##)	CL0480-1078-0-##	40	2	8.57	6.65	7.39	7.89	7.29		
BK13H-60DP/2-0.35V05(8##)	CL0480-1089-0-##	60	2	12.07	10.15	10.89	11.39	10.79		

Note 1 : BK13C and BK13H have different recommended PCB layout.

Note 2 : This connector has no polarity.

BK13H Receptacle (Stacking Height : 1.0mm)

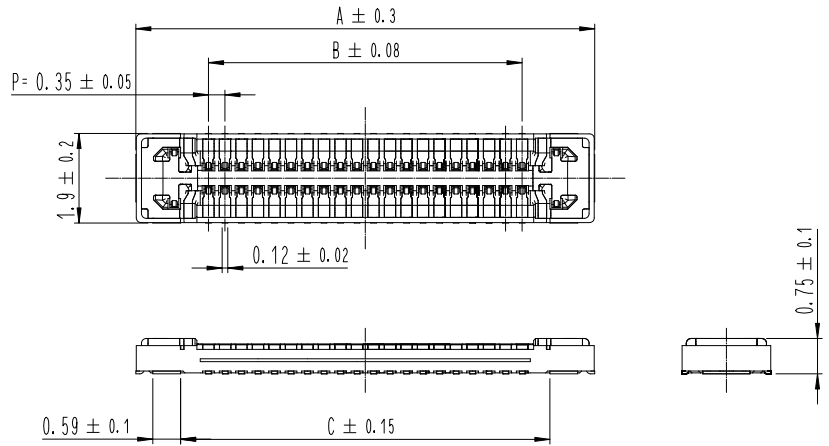

● Recommended PCB Layout

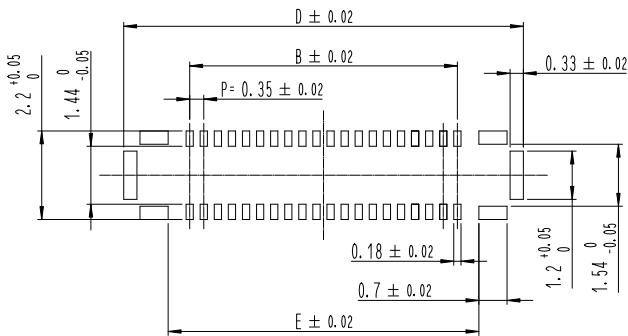

● Recommended Metal Mask Dimensions (Mask Thickness : 0.08mm)

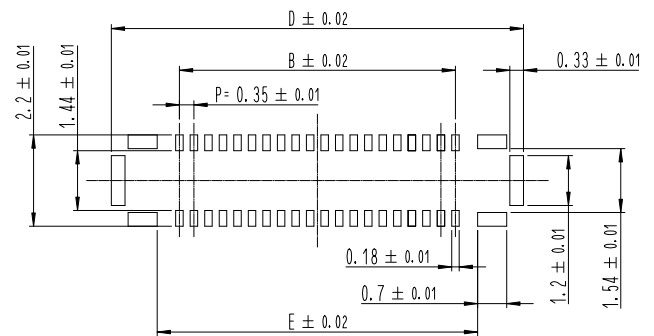

Unit : mm

Part No.	HRS No.	No. of Pos.		A	B	C	D	E	Purchase Unit	
		Signal Contact	Power Contact						## : 00	## : 95
BK13H-40DS/2-0.35V05(8##)	CL0480-1093-0-##	40	2	9.73	6.65	7.83	9.93	7.72	20,000pcs per reel	1,000pcs per reel

Note 1 : BK13C and BK13H have different recommended PCB layout.
 Note 2 : This connector has no polarity.

BK13H Receptacle (Stacking Height : 1.5mm)

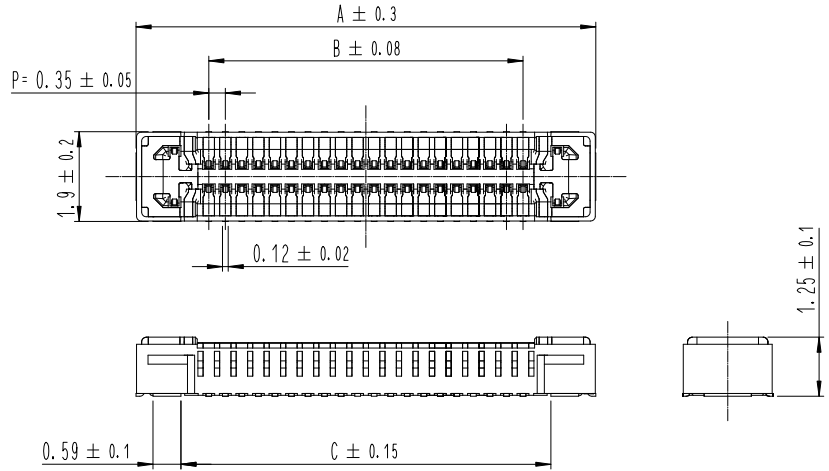

Recommended PCB Layout

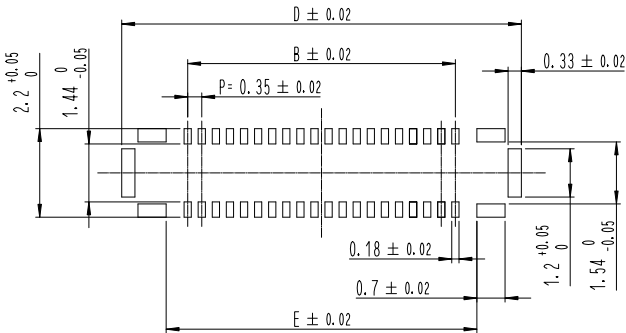

Recommended Metal Mask Dimensions (Mask Thickness : 0.08mm)

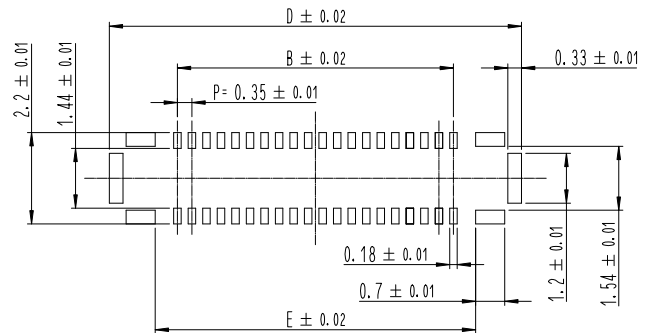

Unit : mm

Part No.	HRS No.	No. of Pos.		A	B	C	D	E	Purchase Unit	
		Signal Contact	Power Contact						## : 00	## : 95
BK13H-30DS/2-0.35V10(8##)	CL0480-1131-0-##	30	2	7.98	4.9	6.08	8.18	5.97	14,000pcs per reel	1,000pcs per reel
BK13H-40DS/2-0.35V10(8##)	CL0480-1079-0-##	40	2	9.73	6.65	7.83	9.93	7.72		
BK13H-60DS/2-0.35V10(8##)	CL0480-1091-0-##	60	2	13.23	10.15	11.33	13.43	11.22		

Note 1 : BK13C and BK13H have different recommended PCB layout.
 Note 2 : This connector has no polarity.

Usage Precautions

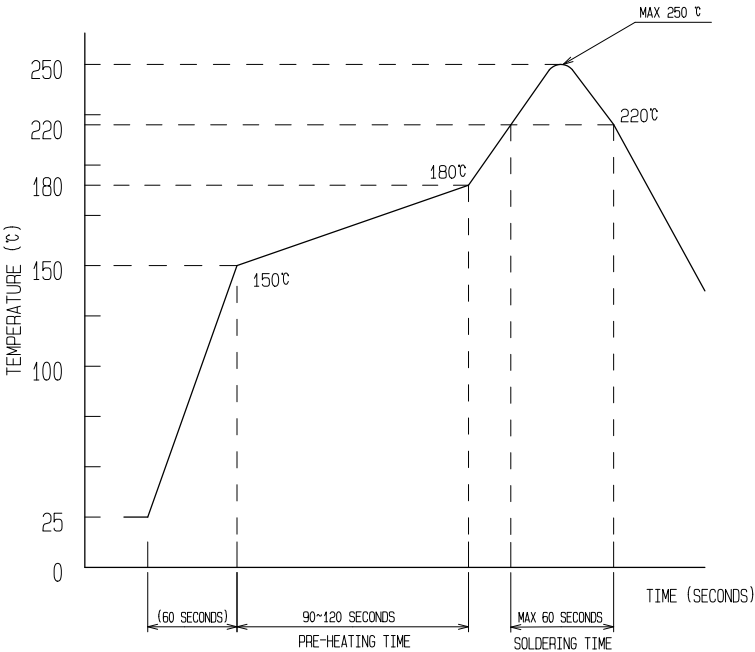
<p>1. Recommended Solder Temperature Profile</p>	 <p>[Conditions]</p> <table border="0"> <tr> <td>1. Peak Temperature</td> <td>: Maximum of 250°C</td> </tr> <tr> <td>2. Heated Section</td> <td>: 220°C Min., within 60 seconds</td> </tr> <tr> <td>3. Preheated Section</td> <td>: 150 to 180°C, 90 to 120 seconds</td> </tr> <tr> <td>4. Number of Reflow Cycles</td> <td>: Maximum of 2 cycles</td> </tr> </table> <p>Note 1 : The temperature is the surface temperature of the PCB in the vicinity of the connector lead part. Note 2 : When using nitrogen reflow process, please mount the product with an oxygen concentration at a minimum of 1,000ppm. Please contact a Hirose representative if the concentration is below 1,000ppm</p>	1. Peak Temperature	: Maximum of 250°C	2. Heated Section	: 220°C Min., within 60 seconds	3. Preheated Section	: 150 to 180°C, 90 to 120 seconds	4. Number of Reflow Cycles	: Maximum of 2 cycles
1. Peak Temperature	: Maximum of 250°C								
2. Heated Section	: 220°C Min., within 60 seconds								
3. Preheated Section	: 150 to 180°C, 90 to 120 seconds								
4. Number of Reflow Cycles	: Maximum of 2 cycles								
<p>2. Recommended Manual Soldering Conditions</p>	<p>Soldering iron temperature : 340±10°C Soldering time : within 3 seconds</p>								
<p>3. Recommended Metal Mask Thickness and Open Area Ratio to PCB Pattern Area</p>	<p>Thickness : 0.08mm Aperture ratio : 100% on the plug side, 100% on the receptacle side</p>								
<p>4. PCB Warpage</p>	<p>A maximum of 0.02mm at the center of the connector with reference to both ends of the connector.</p>								
<p>5. Cleaning</p>	<p>Not recommended. If this product is cleaned, please evaluate the performance before using it. Cleaning may cause a change in the mating/unmating properties as well as environmental resistance.</p>								
<p>6. Notes</p>	<ul style="list-style-type: none"> • Insertion or removal prior to board mounting may result in contact deformation. • Avoid supporting the PCB only with the connectors. Support it by other means such as bolts, screws, posts, etc. • Avoid excessive prying mating/unmating as it may result in damage. • During manual soldering, do not apply flux which will cause solder wicking. • This product may have slight color differences due to production lot variability, but this does not have any effect on the performance. • Please refer to the next page for mating/unmating precautions. • It is advised to secure the mated connectors to the board with housings and cushioning materials because the product can disengage if dropped, by other impact or by FPC routing. • Caution! Do not use the connector outside of the specifications.(i.e., rated current, rated voltage, PCB design and operating environment, etc.).Such usage could lead to material outgassing, ignition, or short-circuit, etc. • Please use a proper stiffener on the back of the FPC. We recommend using a glass epoxy material with a minimum thickness of 0.3mm or a stainless steel material with a minimum of thickness of 0.2mm. 								

Connector Handling Precautions

【Connector Mating Precautions】

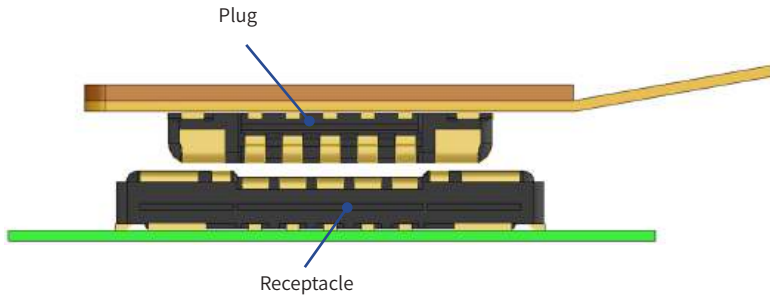

1. Locate the guides and align the connectors to the appropriate mating position. The connector has guide ribs on the receptacle for proper mating alignment. Align the connectors with the guide ribs.

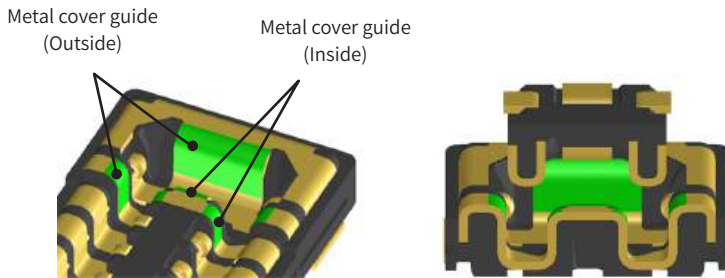

2. When the connector comes to the appropriate position, the connector will lower into place as indicated by the change in mated height.
3. When the connectors has lowered into place, the connector pair will be parallel to each other and cannot be moved back and forth or left and right. Please complete mating from this state by applying force.

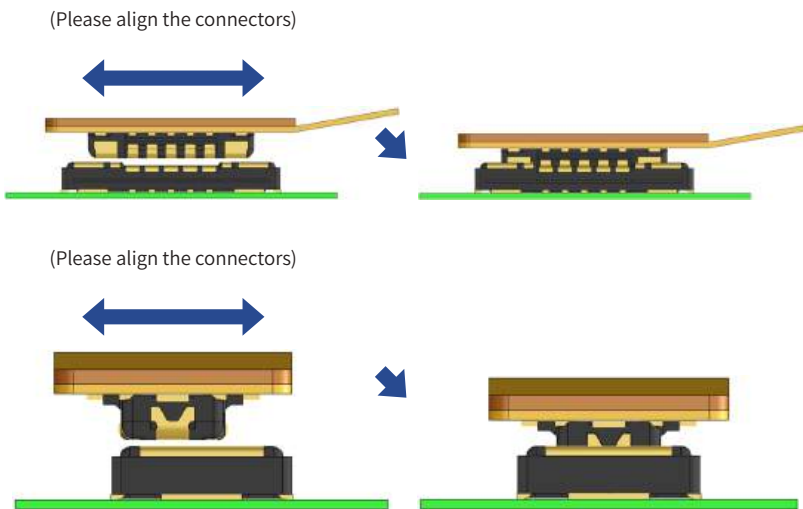

4. Please make sure connectors are mated completely. If one side is floating or the connectors are mated at an angle, please unmate and then redo the mating procedure following the steps described.



【Connector Un-Mating Precautions】

1. It is recommended to remove the connector by pulling perpendicular to the connector mounted surface.
However, unmating FPC-to-board connectors can become more difficult with higher pin count connectors and thinner FPCs.

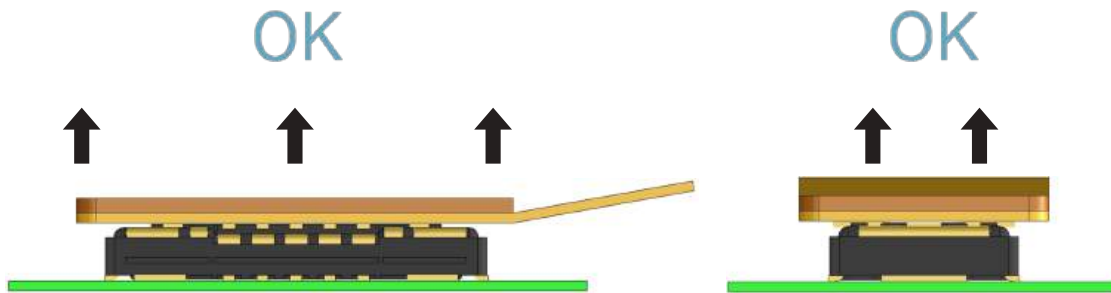

2. If it is difficult to remove the connector parallel to the mounting surface, remove it diagonally towards the pitch direction. Do not remove the connector towards the width direction as it may put a large amount of stress on the contacts.

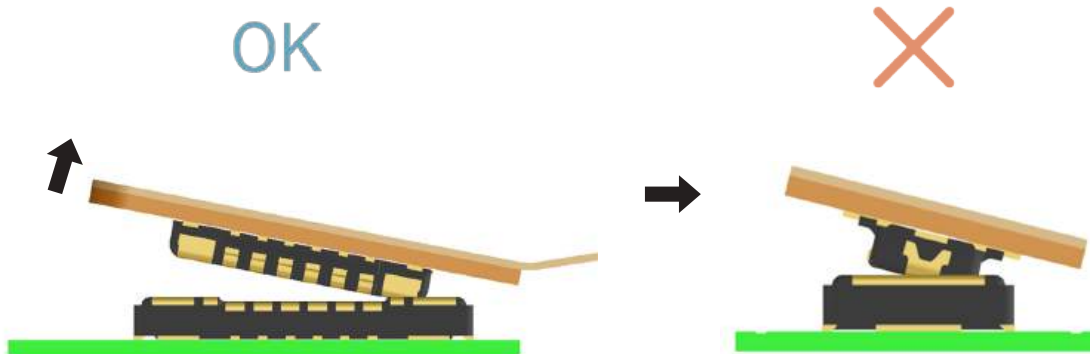

3. If the FPC is not rigid enough, there is a possibility of solder peeling or connector damage.
Please check the repetitive operation of the FPC planned to be used in advance, such as during the early stage build.
Please do not remove the FPC by holding one corner and pulling at a diagonal as this will put a great amount of stress on the contacts.

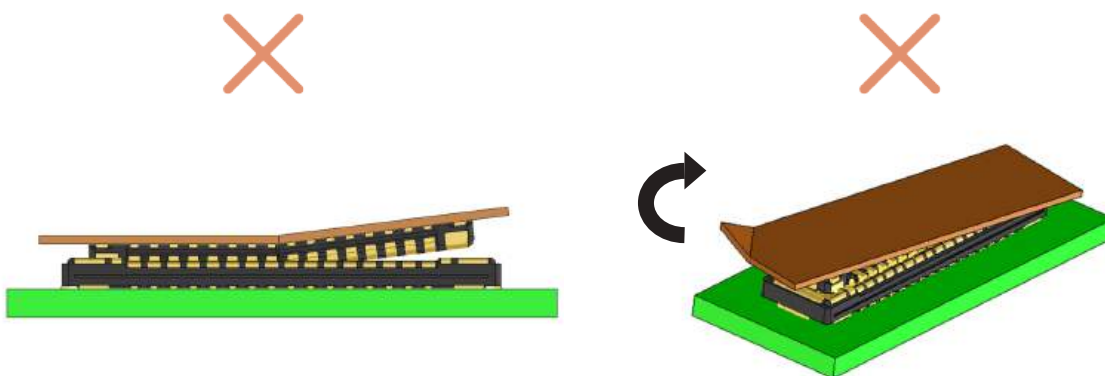

While Taking into Consideration

Specifications mentioned in this catalog are reference values.

When considering to order or use this product, please review the Drawing and Product Specifications sheets.

Use an appropriate cable when using the connector in combination with cables.

If considering usage of a non-specified cable, please contact your sales representative.

If assembly process is done by jigs & tools which are not identified by Hirose, the warranty of the product may be affected.

If considering usage for below mentioned applications, please contact your sales representative.

In cases where the application will demand a high level of reliability, such as automotive, medical instruments, public infrastructure, aerospace/ defense etc. Hirose must review before assurance of reliability can be given.