

MPR *series*

■ Application

- Current sensor for power hybrid applications
- For welding on bus bars
- High current applications for the automotive market
- Frequency converters
- Power modules
- Power rating up to 15 W

■ Features

- Power rating up to 15 W
- Heavy copper connectors
- Excellent long-term stability
- Ideal suited for mounting on DBC / IMS substrate
- High application temperature range -55 to +170°C due to special design
- RoHs compliant and halogen free
- AEC-Q200 qualification

■ Product structure

- (1) - Terminal electrode : Cu
- (2) - Resistor body: CuMn7Sn/MnCu/Kamar
- (3) - Terminal electrode : Cu
- (4) - Marking: Laser Marking

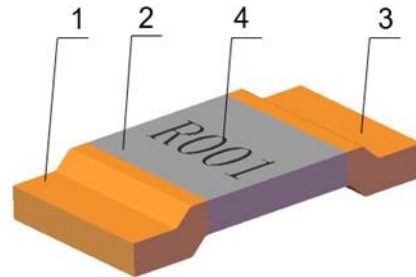

■ Part Number Explanation

MPR	3921	08	F	R005
Product Type	Size (Inch)	Rated Power	Tolerance	Resistance
MPR	2512 3921 5931	03=3W 04=4W 05=5W 06=6W 07=7W 08=8W 09=9W 10=10W 12=12W 15=15W	D=±0.5% F=±1% G=±2% J=±5%	0M50=0.5mΩ R001=1mΩ R002=2mΩ R005=5mΩ

Standard Electrical Specifications

Type	Part Number	Rated Power /W	TCR ppm/°C	Resistance /mΩ	Material	Applicable temperature range /°C
2512	MPR251206F0M20	6	±200	0.2	CuMn7Sn	-55~170
	MPR251206F0M30	6	±200	0.3	CuMn7Sn	
	MPR251206F0M50	6	±100	0.5	MnCu	
	MPR251205FR001	5	±100	1	MnCu	
	MPR251205FR002	5	±50	2	Kamar	
	MPR251204FR003	4	±50	3	Kamar	
	MPR251203FR004	3	±50	4	Kamar	
	MPR251203FR005	3	±50	5	Kamar	
3921	MPR392112F0M20	12	±200	0.2	CuMn7Sn	-55~170
	MPR392110F0M30	10	±100	0.3	MnCu	
	MPR392109F0M50	9	±100	0.5	MnCu	
	MPR392107FR001	7	±50	1	MnCu	
	MPR392106FR002	6	±50	2	Kamar	
	MPR392105FR003	5	±50	3	Kamar	
	MPR392105FR004	5	±50	4	Kamar	
	MPR392105FR005	5	±50	5	Kamar	
5931	MPR593115F0M10	15	±200	0.1	CuMn7Sn	-55~170
	MPR593115F0M20	15	±100	0.2	MnCu	
	MPR593110F0M30	10	±100	0.3	MnCu	
	MPR593108F0M50	8	±100	0.5	MnCu	
	MPR593110FR001	10	±50	1	Kamar	
	MPR593107FR002	7	±50	2	Kamar	
	MPR593107FR003	7	±50	3	Kamar	

Type Dimension

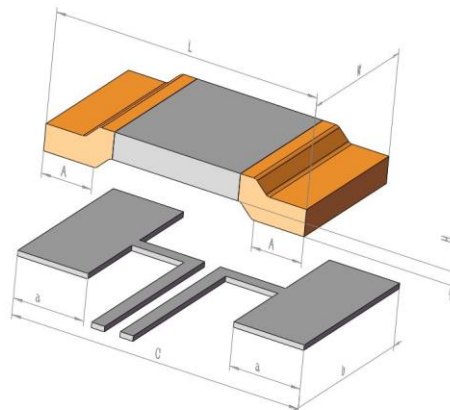

■ **Standard Electrical Dimension**

Unit: mm

Type	Resistance Range (mΩ)	L	W	H	A
2512	0.2-5	6.3±0.2	3.1±0.3	0.4±0.1	1.2±0.2
3921	0.2-5	10.0±0.2	5.2±0.3	0.5±0.1	2.0±0.2
5931	0.1-3	15.0±0.2	7.7±0.3	0.5±0.1	4.2±0.3

■ **PCB-layout proposal**

Unit: mm

Type	a	b	c
2512	1.8	3.6	7.0
3921	2.7	6.2	11.0
5931	5.2	8.7	16.0

■ **Power Derating Curve**

The Operating Temperature Range: -55°C ~+170°C

For resistors operated in ambient temperatures above 70°C, power rating must be derated in accordance with the curve below

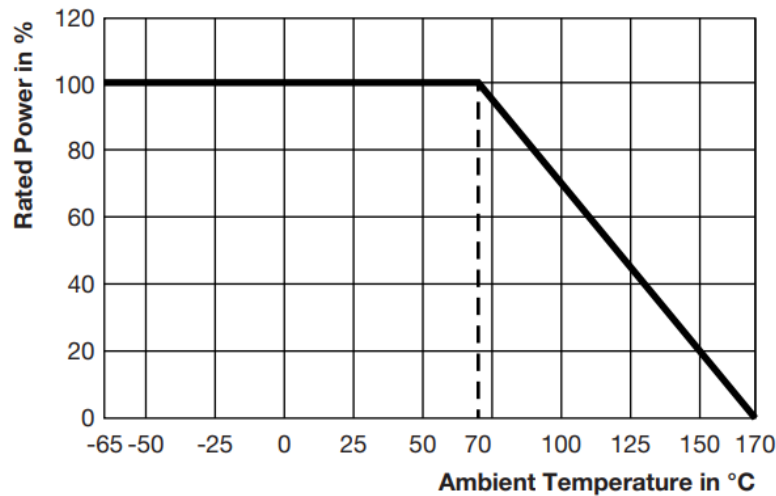

■ **Rating Current**

The following equation may be used to determine the DC (Direct Current) or AC (Alternating Current) (RMS, root mean square value) of normal rated power. However, if the result value exceeds the highest current of regulated standards (paragraph 5), the highest normal rated power is to be used

$$I = \sqrt{P/R}$$

I= Rating current (A)

P= Rating Power (W)

R= Resistance(Ω)

■ Reliability Test and Requirement

Test Item	Test Method	Procedure	Requirements
Temperature Coefficient of Resistance (T.C.R)	MIL-STD-202 Method 304	$TCR \text{ (ppm/}^\circ\text{C)} = \frac{(R2-R1)}{R1(T2-T1)} \times 10^6$ R1: resistance at 25°C (T1) R2: resistance at 125°C (T2)	Refer to Electrical Specification
Short Time Overload	JIS C 5201-1 clause 4.13	The number of rated power are as follows: 5 times of rated power Rating power duration: 5secs	±1.0%
High Temperature Exposure	JIS C 5201-1 clause 4.23.2	170°C±2°C for 1000hrs	±1.0%
Low Temp. Storage	JIS C 5201-1 clause 4.23.4	-55°C±2°C for 1000hrs	±1.0%
Soldering Heat	MIL-STD-202 Method 210	260±5°C for 10±1 seconds.	±1.0%
Temperature Cycling	JIS C 5201-1 clause 4.19	-55°C to +155°C, 100 cycles	±1.0%
Load Life	MIL-STD-202 Method 108	70°C± 2°C, 1000 hours, at rated power 1.5 hours "ON", 0.5 hours "OFF"	±1.0%
Temperature Humidity Bias Test	MIL-STD-202 Method 103	+85°C, 85% RH, 10%bias, 1000hours	±0.5%
Mechanical shock	MIL-STD-202 Method 213	100 g'sec ,6 msec, 5puls	±0.5%
Vibration	MIL-STD-202 Method 204	Frequency varied 10 Hz to 2000 Hz in 1 min, 3 directions, 12 h	±1.0%
Moisture resistance	MIL-STD-202 Method 106	MIL-STD-202,method 106, No power, 7a and 7b not required	±1.0%

■ Marking Format

- All type products marking are 4 digits.
 "R" designates the decimal location in ohms
 e.g. 1mΩ the product marking is R001.
 5mΩ the product marking is R005 .
 "M" designates the decimal location in milli-ohms
 e.g. 0.2mΩ the product marking is 0M20.
 0.5mΩ the product marking is 0M50.
 2.5mΩ the product marking is 2M50.
- The criteria to distinguishing the mark on the surface of products are that characters can be identified.

■ Recommended IR Reflow Profile

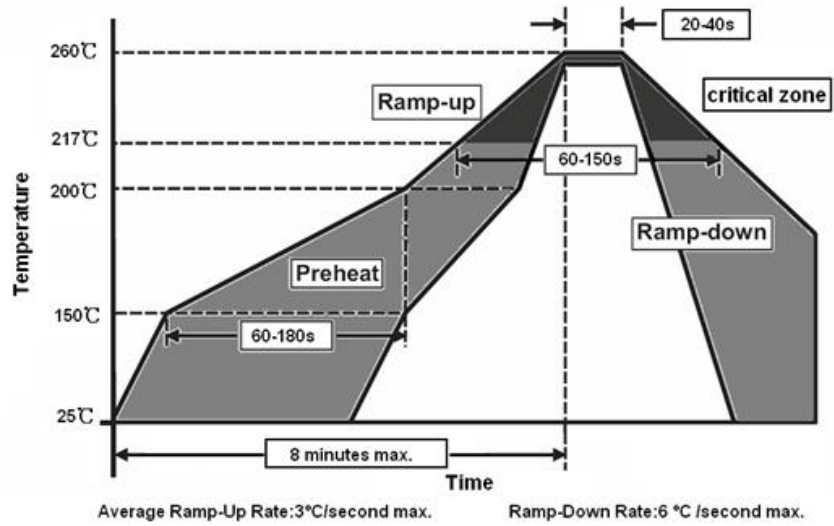

■ Quantity of Package

Type	Resistance Value /mΩ	Quantity /Pcs
2512	0.2-5	4000
3921	0.2-5	3000
5931	0.1-3	2000

■ Reel Dimensions

Unit: mm

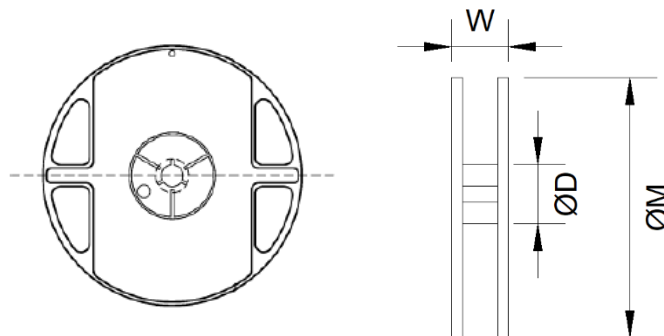

TYPE	φD	W	φM
2512	100.0±1.0	17.0±1.0	330.0±2.0
3921	100.0±1.5	28.5±2.0	330.0±2.0
5931	100.0±1.5	28.5±2.0	330.0±2.0

Carrier Dimensions

Unit: mm

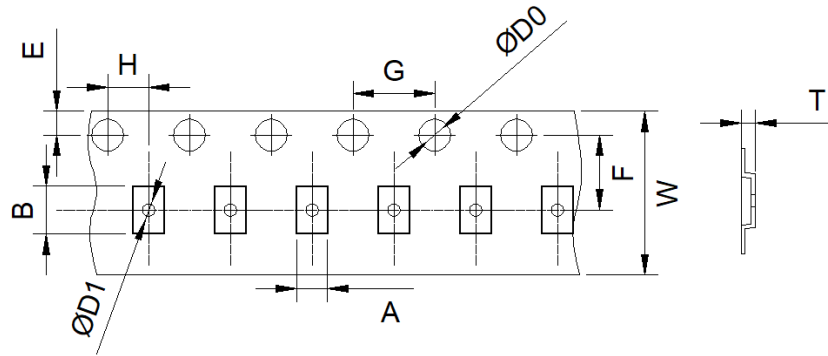

Item	W	E	F	ØD0	ØD1	G	H	A	B	T
2512	12.0±0.2	1.75±0.1	5.5±0.1	1.5±0.1	1.5±0.1	4.0±0.1	2.0±0.1	3.5±0.2	6.8±0.2	1.0±0.1 2.0±0.1
3921	24.0±0.3	1.75±0.1	11.5±0.1	1.5±0.1	1.5±0.1	4.0±0.1	2.0±0.1	6.0±0.2	10.6±0.2	1.2±0.1 2.5±0.1
5931	24.0±0.3	1.75±0.1	11.5±0.1	1.5±0.1	1.5±0.1	4.0±0.1	2.0±0.1	8.6±0.2	15.6±0.2	1.2±0.1 2.35±0.1

Peeling Strength of Top Cover Tape

Peeling Strength: 0.1-1.0N at a peel-off speed of 300 mm/min.

Storage Requirement

Temperature: 5~30°C, Humidity: ≤75%RH

Sealed plastic bags with desiccant shall be used to reduce the oxidation of the termination and shall only be opened prior to use.

The products shall not be stored in areas where harmful gases containing sulfur or chlorine are present.

When the product is finally discarded, it can be treated as general electronic waste, and raw material compositions of CSR can be referred to MSDS.