

1. Description

UMW L9110S is a two-channel push-pull power amplifier ASIC designed to control the driving motor. It integrates discrete circuits into a single IC, which reduces the number of peripheral devices, reduces the cost and improves the reliability of the whole machine.

UMW L9110S chip has two input control terminals, which can control two output terminals to directly drive the forward and backward rotation of the motor.

The chip is widely used in motor drive of toy cars, pulse electromagnetic valve drive, stepping motor drive, switching power tube and other circuits.

3. Product Usage

- Pulse electromagnetic valve drive
- Toy car motor drive

2. Features

- The power supply range is 2.2~6.5V
- Low static operating current
- Lower saturation pressure drop
- $V_{CC}=5V$, maximum operating current 200mA
- TTL/CMOS output level is compatible and can be directly connected with CPU I/O
- Few external devices
- Package: DIP8, SOP8

- Stepping motor drive
- Drive switch power transistor



4. Pinning Information

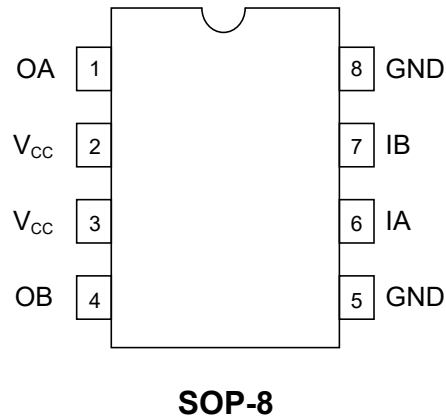

Pin Description

Pin Number	Pin Name	Describe
1	OA	A Output pin
2	V _{CC}	Positive pole of power supply
3	V _{CC}	Positive pole of power supply
4	OB	B Output pin
5	GND	Power ground
6	IA	A Input terminal
7	IB	B Input terminal
8	GND	Power ground



5.Limit Parameter

Project	Parameter	Symbol	Rating	Units
Voltage	Power Supply Voltage	V_{CC}	-0.3 to 8	V
	Input Voltage	V_{IN}	-0.3 to V_{CC}	V
Dissipation power	SOP8/DIP8	P_D	500	mW
Temperature	Operating Temperature Range	T_W	-30 to 85	°C
	Storage Temperature Range	T_C	-50 to 125	°C
	Welding Temperature	T_H	260	°C,10s

Note: Limit parameter refers to the limit value that cannot be exceeded under any condition. If this limit value is exceeded, it may cause physical damage such as product deterioration. At the same time, when the parameters are close to the limit, the chip can not be guaranteed to work normally.

6.Electrical characteristics ($T_A=25^{\circ}\text{C}$, $V_{CC}=5\text{V}$)

Parameter	Symbol	Conditions	Min	Typ	Max	Units
Operating Voltage	V_{CC}		2.2	5	6.5	V
Quiescent Current	I_{CC}	Operate without load		0.2	2	μA
Incoming Current	I_{IN}	$V_{IN}=V_{DD}$ or GND		0.1	2	μA
Input Low Voltage	V_{INL}	I_A, I_B	0		$0.25V_{CC}$	V
Input High Voltage	V_{INH}	I_A, I_B	$0.7V_{CC}$		V_{CC}	V
Output Saturation Voltage	V_{AB1}	$I_{OUT}=100\text{mA}$		0.19	0.25	V
Output Saturation Voltage	V_{AB2}	$I_{OUT}=180\text{mA}$		0.36	0.45	V



7. Input Waveform Diagram

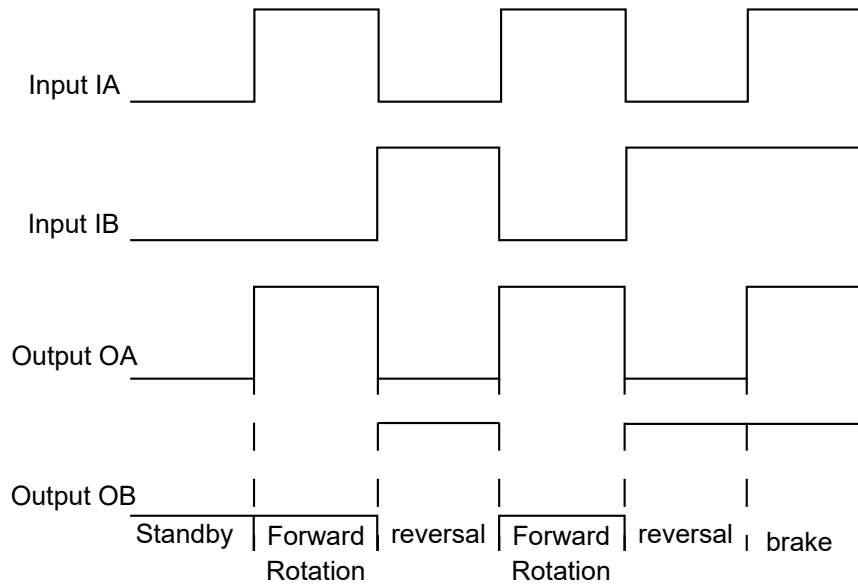

8. Logic Diagram

Input		Output		Remarks
IA	IB	OA	OB	
L	L	Z	Z	Standby
L	H	L	H	Forward/Reverse rotation
H	L	H	L	Reverse/Forward rotation
H	H	Z	Z	Brake



9. Typical Application

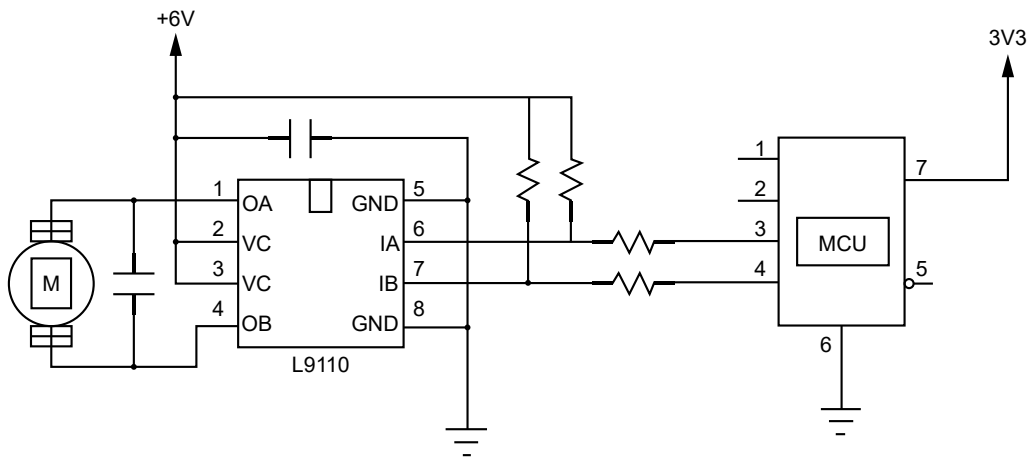
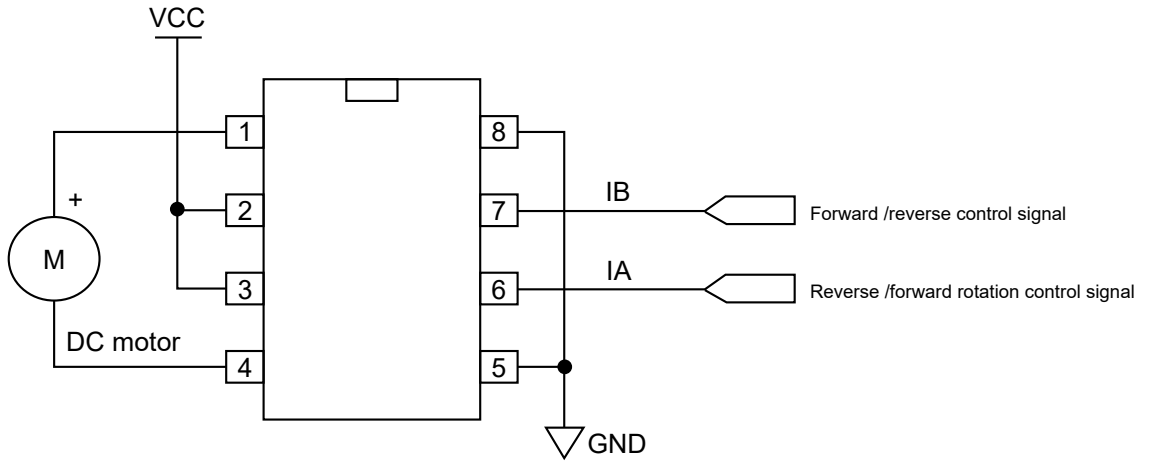



10.SOP-8 Package Outline Dimensions

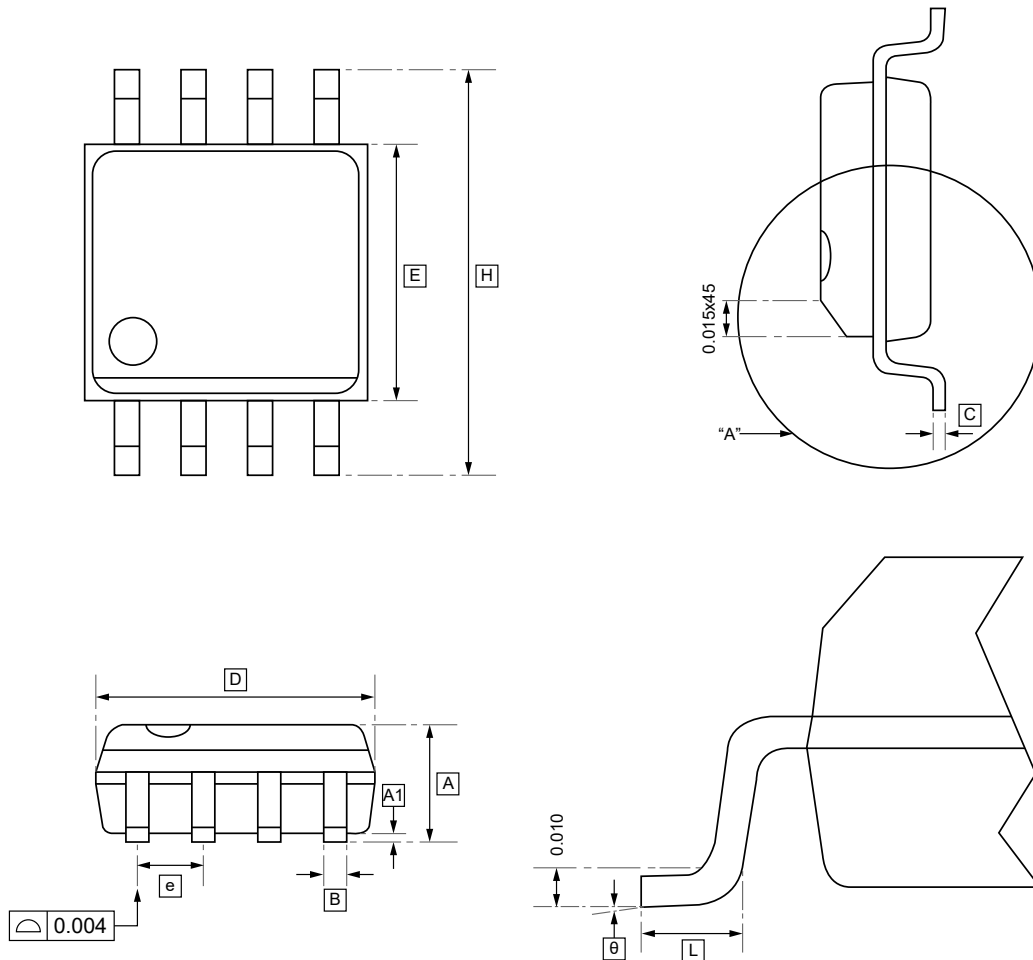

DIMENSIONS (mm are the original dimensions)

Symbol	A	A1	B	C	D	E	e	H	L	θ
Min	1.473	0.101	0.330	0.190	4.8	3.7	1.27	5.791	0.381	0°
Max	1.727	0.254	0.508	0.249	5.2	4.0		6.197	1.27	8°



11. Ordering Information

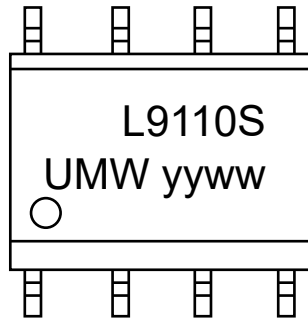

yy: Year Code
ww: Week Code

Order Code	Package	Base QTY	Delivery Mode
UMW L9110S	SOP-8	2500	Tape and reel



12.Disclaimer

UMW reserves the right to make changes to all products, specifications. Customers should obtain the latest version of product documentation and verify the completeness and currency of the information before placing an order.

When applying our products, please do not exceed the maximum rated values, as this may affect the reliability of the entire system. Under certain conditions, any semiconductor product may experience faults or failures. Buyers are responsible for adhering to safety standards and implementing safety measures during system design, prototyping, and manufacturing when using our products to prevent potential failure risks that could lead to personal injury or property damage.

Unless explicitly stated in writing, UMW products are not intended for use in medical, life-saving, or life-sustaining applications, nor for any other applications where product failure could result in personal injury or death. If customers use or sell the product for such applications without explicit authorization, they assume all associated risks.

When reselling, applying, or exporting, please comply with export control laws and regulations of China, the United States, the United Kingdom, the European Union, and other relevant countries, regions, and international organizations.

This document and any actions by UMW do not grant any intellectual property rights, whether express or implied, by estoppel or otherwise. The product names and marks mentioned herein may be trademarks of their respective owners.