

# MDDG06R02G

60V N-Channel Enhancement Mode MOSFET

## 1. Description

This N-Channel MV MOSFET is produced using MDD Semiconductor's advanced Power Trench process that incorporates Shielded Gate technology. This process has been optimized to minimize on-state resistance and yet maintain superior switching performance with best in class soft body diode.

## 2. Features

- Max  $R_{DS(on)}$  = 2.5 m $\Omega$  at  $V_{GS} = 10$  V,  $I_D = 35$  A
- Extremely Low Reverse Recovery Charge,  $Q_{rr}$
- 100% UIS Tested
- 100% dVDS Tested

## 3. Application

- PWM Application
- Motor Drives and Uninterruptible Power Supplies
- Micro Solar Inverter
- Battery management System

## 4. Absolute Maximum Ratings ( $T_A=25^\circ\text{C}$ unless otherwise noted)

Parameter	Symbol	Value	Unit
Drain-Source Voltage	$V_{DS}$	60	V
Gate-Source Voltage	$V_{GS}$	$\pm 20$	V
Continuous Drain Current (Note 1)	$I_D$	200	A
Pulsed Drain Current (Note 2)	$I_{DM}$	800	A
Single Pulsed Avalanche Energy (Note 3)	$E_{AS}$	342	mJ
Thermal Resistance, steady-state	$R_{\theta JA}$	42	$^\circ\text{C}/\text{W}$
Power Dissipation	$P_D$	156	W
Junction Temperature	$T_J$	-55~+150	$^\circ\text{C}$
Storage Temperature	$T_{stg}$	-55~+150	$^\circ\text{C}$

Note: 1) Calculated continuous current based on maximum allowable junction temperature.

2) Repetitive rating, pulse width limited by max. junction temperature.

3)  $E_{AS}$  condition :  $T_J=25^\circ\text{C}$ ,  $V_{DD}=30\text{V}$ ,  $V_{GS}=10\text{V}$ ,  $L=0.5\text{mH}$ ,  $R_g=25\ \Omega$ ,  $I_{AS}=37\text{A}$ .

### 5. Pinning information

Pin	Symbol	Description	Simplified outline	Equivalent Circuit	Marking	Package
4	G	Gate			MDD G06R02G	PDFN5*6-8L
5-8	D	Drain				
1-3	S	Source				

### 6. $T_A=25^\circ\text{C}$ unless otherwise specified

Symbol	Parameter	Condition	Min	Typ	Max	Unit	
$V_{(BR)DSS}$	Drain-Source Breakdown Voltage	$V_{GS}=0V, I_D=250\mu A$	60	—	—	V	
$I_{GSS}$	Gate-Source Leakage Current	Forward	$V_{GS}=20V$	—	—	100	nA
		Reverse	$V_{GS}=-20V$	—	—	-100	nA
$I_{DSS}$	Drain-Source Leakage Current	$V_{DS}=60V, V_{GS}=0V$	—	—	1	$\mu A$	
$V_{GS(TH)}$	Gate Threshold Voltage	$V_{DS}=V_{GS}, I_D=250\mu A$	1.4	1.6	2.5	V	
$R_{DS(ON)}$	Drain-Source On-State Resistance	$V_{GS}=10V, I_D=35A$	—	2.0	2.5	m $\Omega$	
		$V_{GS}=4.5V, I_D=30A$	—	2.7	3.4	m $\Omega$	

### 7. Dynamic Electrical Characteristics

Symbol	Parameter	Condition	Min	Typ	Max	Unit
$C_{iss}$	Input Capacitance	$V_{GS}=0V$	—	5600	—	pF
$C_{oss}$	Output Capacitance	$V_{DS}=25V$	—	2400	—	pF
$C_{rss}$	Reverse Transfer Capacitance	$f=1MHz$	—	110	—	pF
$Q_g$	Total Gate Charge	$V_{GS}=10V$	—	101	—	nC
$Q_{gs}$	Gate Source Charge	$V_{DS}=30V$	—	17	—	nC
$Q_{gd}$	Gate Drain Charge	$I_D=30A$	—	22	—	nC

### 8. Switching Characteristics

Symbol	Parameter	Condition	Min	Typ	Max	Unit
$t_{d(on)}$	Turn on Delay Time	$V_{GS}=10V$ $V_{DD}=30V$ $I_D=30A$ $R_G=3\Omega$	—	16	—	ns
$t_r$	Turn on Rise Time		—	38	—	ns
$t_{d(off)}$	Turn Off Delay Time		—	78	—	ns
$t_f$	Turn Off Fall Time		—	95	—	ns

### 9. Source Drain Diode Characteristics

Symbol	Parameter	Condition	Min	Typ	Max	Unit
$V_{SD}$	Drain-Source Diode Forward Voltage	$I_S=30A, V_{GS}=0V$	—	0.82	1.2	V
$t_{rr}$	Body Diode Reverse Recovery Time	$I_F=30A$	—	54.7	—	ns
$Q_{rr}$	Body Diode Reverse Recovery Charge	$di/dt=100A/\mu s$	—	60	—	nC

### 10. Test Circuits And Waveforms

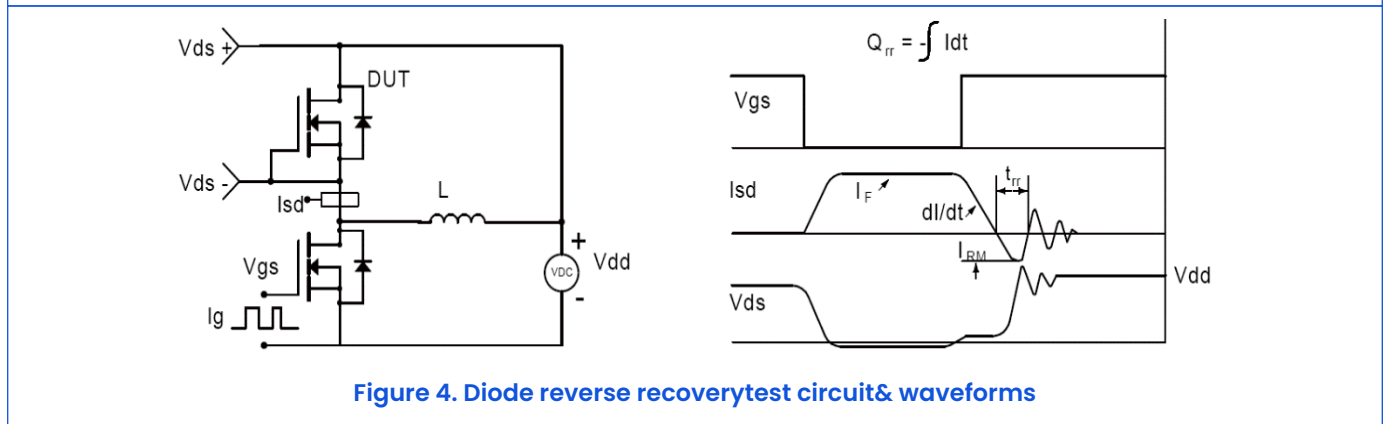
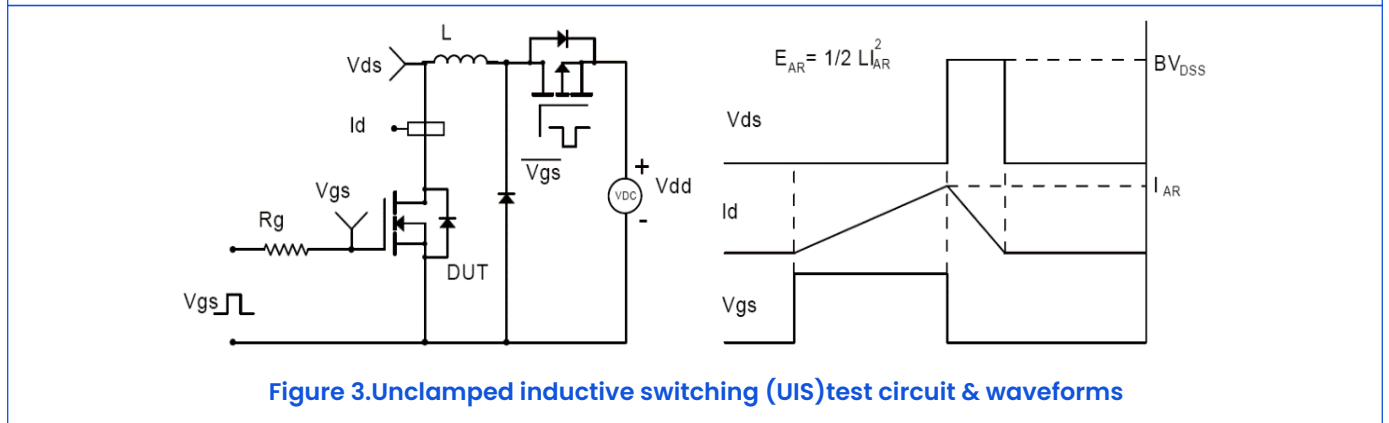
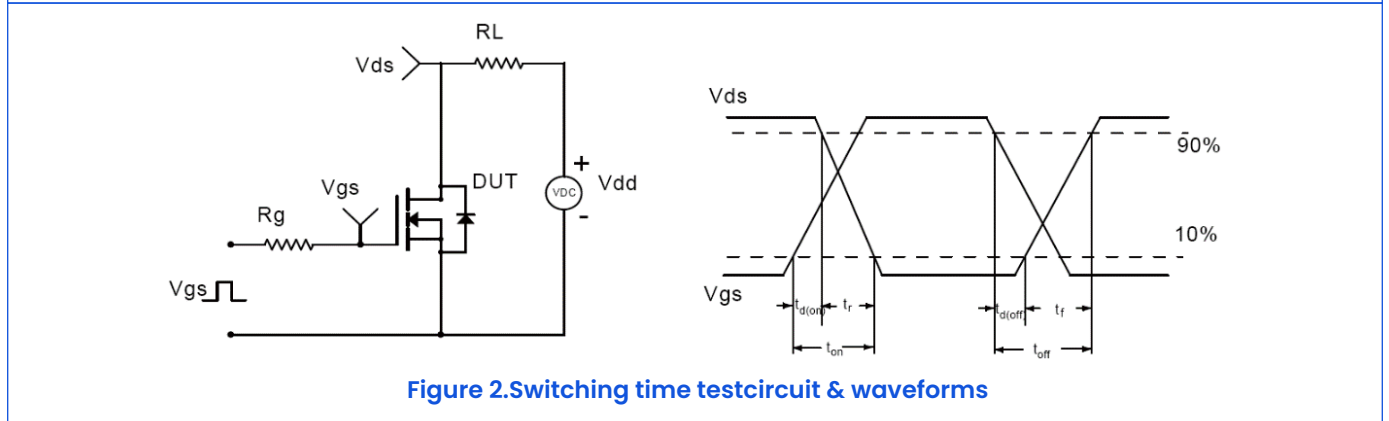
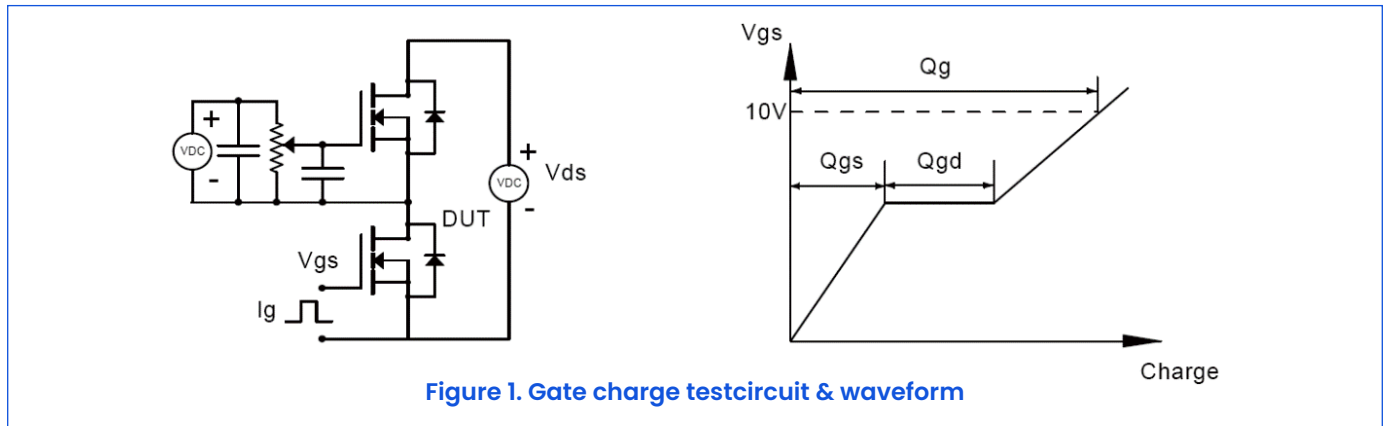

### II. Electrical Characteristics Diagrams

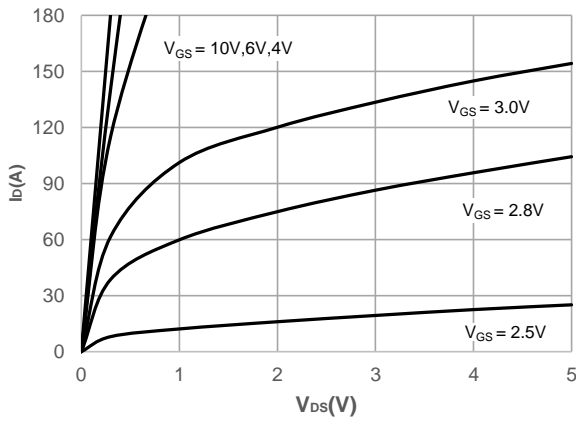

Figure 1. Typ. output characteristics

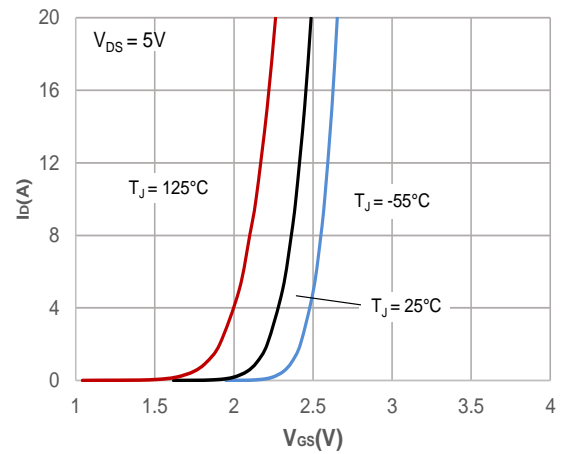

Figure 2. Typ. transfer characteristics

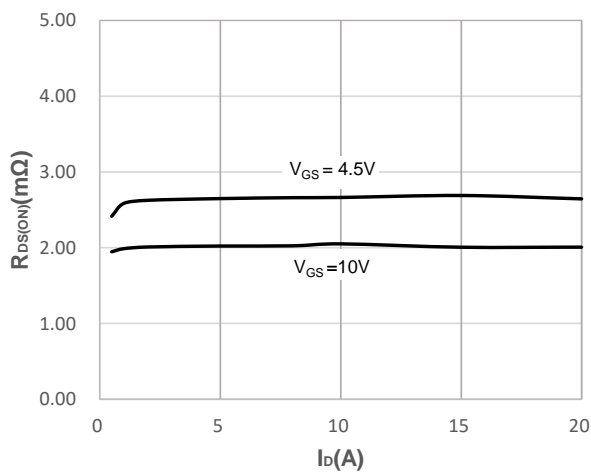

Figure 3. On-Resistance vs. Drain Current

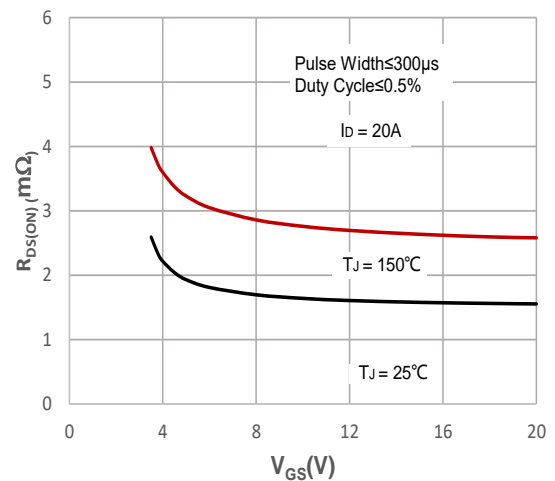

Figure 4. On-Resistance vs. Gate Voltage

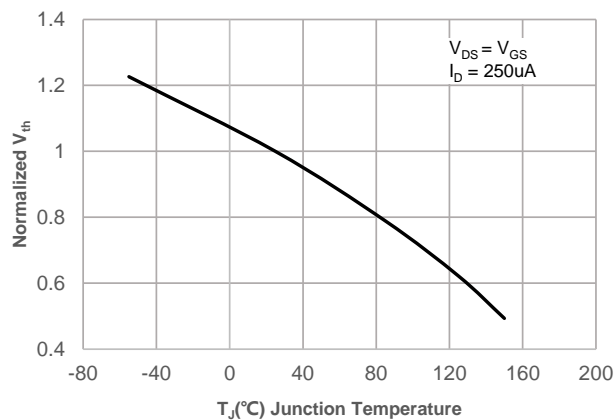

Figure 5. Normalized Threshold Voltage vs. Junction Temperature

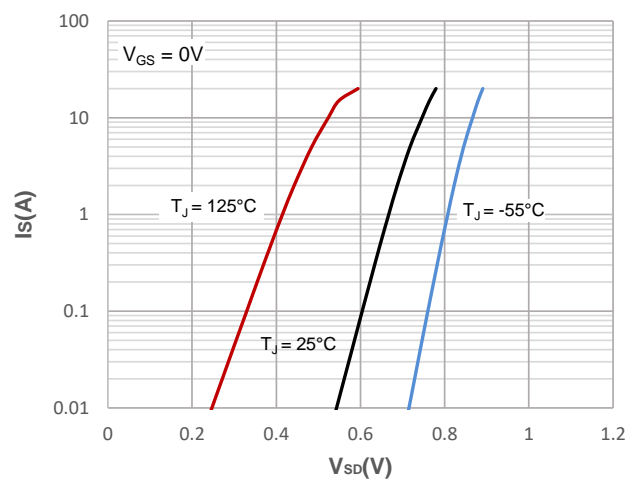
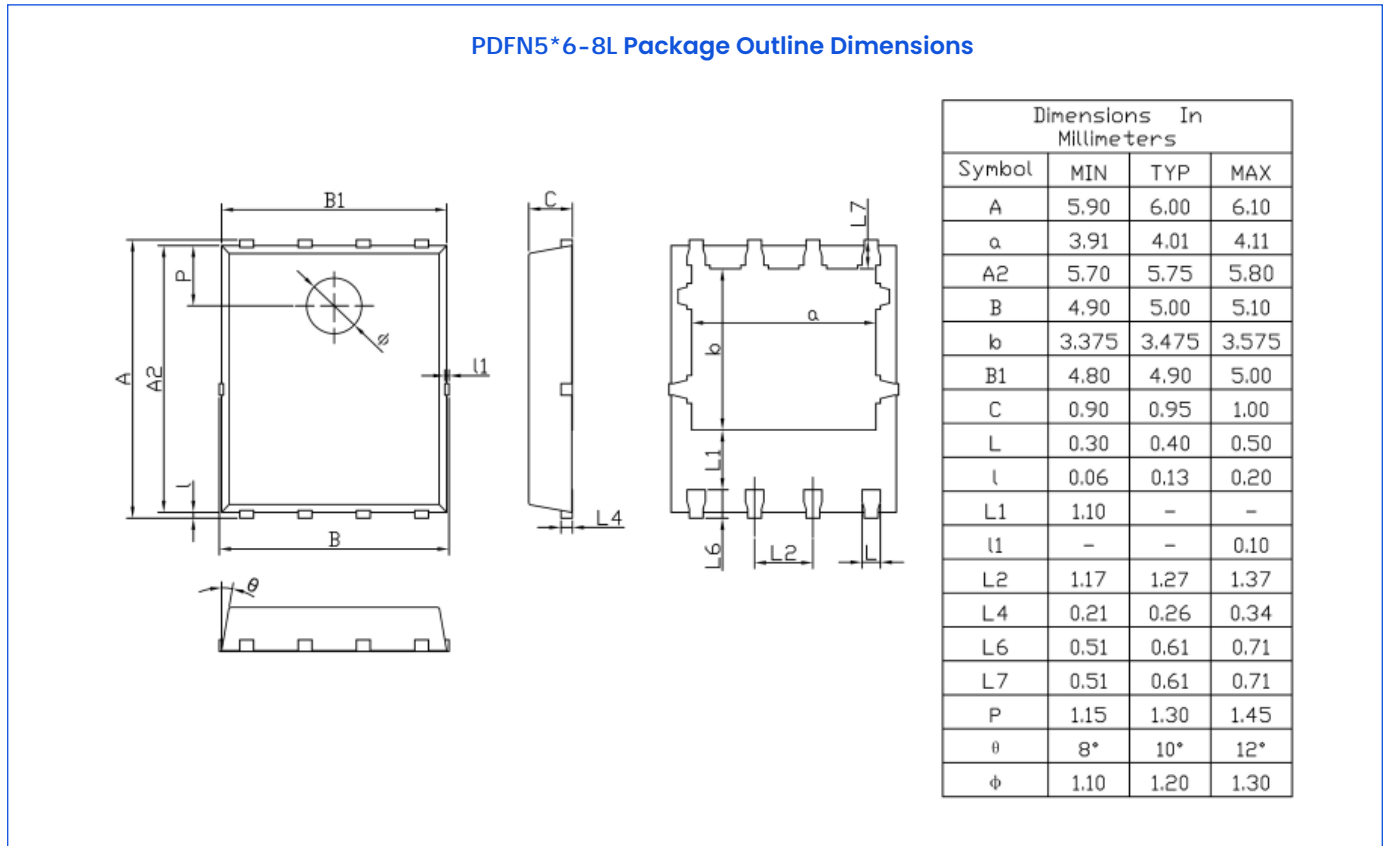

Figure 6. Forward characteristic of body diode

### 12. Outline Drawing



### 13. Important Notice and Disclaimer

Microdiode Electronics (Shenzhen) reserves the right to make changes to this document and its products and specifications at any time without notice. Customers should obtain and confirm the latest product information and specifications before final design, purchase or use.

Microdiode Electronics (Shenzhen) makes no warranty, representation or guarantee regarding the suitability of its products for any particular purpose, not does Microdiode Electronics (Shenzhen) assume any liability for application assistance or customer product design. Microdiode Electronics (Shenzhen) does not warrant or accept any liability with products which are purchased or used for any unintended or unauthorized application.

No license is granted by implication or otherwise under any intellectual property rights of Microdiode Electronics (Shenzhen).

Microdiode Electronics (Shenzhen) products are not authorized for use as critical components in life support devices or systems without express written approval of Microdiode Electronics (Shenzhen).