

74HC14D-HX/74HC14S-HX High-speed cmos logic hex inverting schmitt trigger

Description

The 74HC14D-HX/74HC14S-HX is a hex inverter featuring Schmitt-trigger inputs. This device incorporates reduced input threshold voltages to ensure seamless interfacing with TTL logic levels. Its inputs are equipped with integrated clamp diodes, enabling the use of external current-limiting resistors when connecting to input signals exceeding V_{CC} . The Schmitt-trigger inputs convert slowly varying input waveforms into clean, well-defined, and jitter-free output signals.

Features

- ★ Input levels:
 - For 74HC14D-HX/74HC14S-HX: CMOS level
- ★ Low-power dissipation
- ★ Specified from -40°C to $+125^{\circ}\text{C}$
- ★ ESD protection:
 - HBM: ANSI/ESDA/JEDEC JS-001 2023 exceeds 3500 V
 - CDM: ANSI/ESDA/JEDEC JS-002 2022 exceeds 2000 V
- ★ Latch-up performance ≤ 250 mA
- ★ Packaging information: DIP14/SOP14

Block diagram

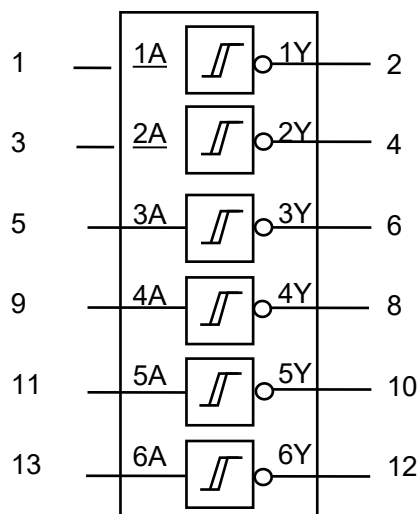

Figure 1. Logic symbol

Block diagram(Continued)

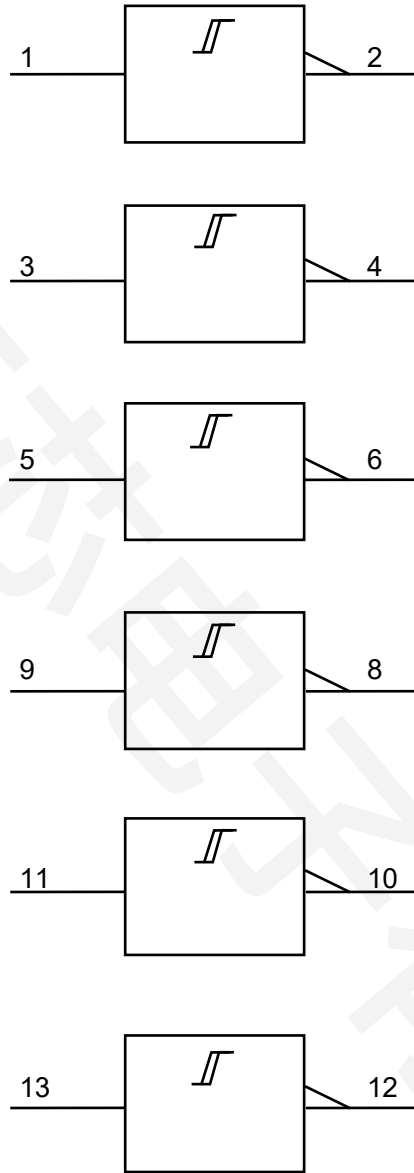

Figure 2. IEC logic symbol

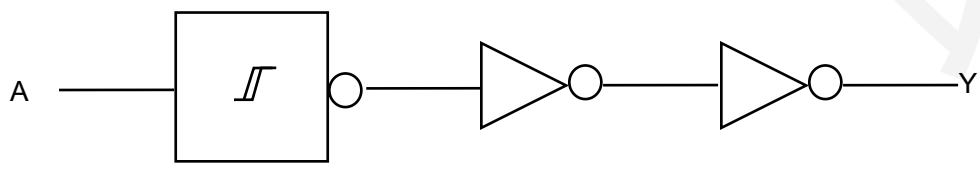
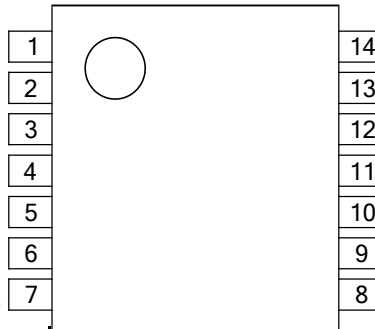

Figure 3. Logic diagram for one gate

Pin configuration and pin description



Pin No.	Pin Name	Description
1	1A	data input
2	1Y	data output
3	2A	data input
4	2Y	data output
5	3A	data input
6	3Y	data output
7	GND	ground (0V)
8	4Y	data output
9	4A	data input
10	5Y	data output
11	5A	data input
12	6Y	data output
13	6A	data input
14	VCC	supply voltage

Function table

Input	Output
nA	nY
L	H
H	L

Note: H=HIGH voltage level; L=LOW voltage level.

Electrical parameter

1. Absolute Maximum Ratings

Voltages are referenced to GND (ground=0V), unless otherwise specified.

Parameter	Symbol	Conditions	Min	Max	Unit
supply voltage	V_{CC}	-	-0.5	+7	V
input clamping current	I_{IK}	$V_I < -0.5V$ or $V_I > V_{CC}+0.5V$	-	± 20	mA
output clamping current	I_{OK}	$V_O < -0.5V$ or $V_O > V_{CC}+0.5V$	-	± 20	mA
output current	I_O	$-0.5V < V_O < V_{CC}+0.5V$	-	± 25	mA
supply current	I_{CC}	-	-	50	mA
ground current	I_{GND}	-	-50	-	mA
total power dissipation	P_{tot}	-	-	500	mW
storage temperature	T_{stg}	-	-65	+150	°C
soldering temperature	T_L	10s	DIP	245	°C
			SOP	260	

2. Recommended Operating Conditions

Parameter	Symbol	Conditions	Min	Typ	Max	Unit
supply voltage	V_{CC}	-	2.0	5.0	6.0	V
input voltage	V_I	-	0	-	V_{CC}	V
output voltage	V_O	-	0	-	V_{CC}	V
ambient temperature	T_{amb}	-	-40	-	+125	°C

Electrical Characteristics

1. DC Characteristics 1

($T_{amb}=25^\circ\text{C}$, voltages are referenced to GND (ground=0V), unless otherwise specified.)

Parameter	Symbol	Conditions	Min	Typ	Max	Unit	
HIGH-level output voltage	V_{OH}	$V_I=V_{T+}$ or V_{T-}	$I_O=-20\mu\text{A}; V_{CC}=2.0V$	1.9	2.0	-	V
			$I_O=-20\mu\text{A}; V_{CC}=4.5V$	4.4	4.5	-	V
			$I_O=-20\mu\text{A}; V_{CC}=6.0V$	5.9	6.0	-	V
			$I_O=-4.0\text{mA}; V_{CC}=4.5V$	3.98	4.32	-	V
			$I_O=-5.2\text{mA}; V_{CC}=6.0V$	5.48	5.81	-	V
LOW-level output voltage	V_{OL}	$V_I=V_{T+}$ or V_{T-}	$I_O=20\mu\text{A}; V_{CC}=2.0V$	-	0	0.1	V
			$I_O=20\mu\text{A}; V_{CC}=4.5V$	-	0	0.1	V
			$I_O=20\mu\text{A}; V_{CC}=6.0V$	-	0	0.1	V
			$I_O=4.0\text{mA}; V_{CC}=4.5V$	-	0.15	0.26	V
			$I_O=5.2\text{mA}; V_{CC}=6.0V$	-	0.16	0.26	V
input leakage current	I_I	$V_I=V_{CC}$ or GND; $V_{CC}=6.0V$	-	-	± 1	μA	
supply current	I_{CC}	$V_I=V_{CC}$ or GND; $I_O=0\text{A}$; $V_{CC}=6.0V$	-	-	2.0	μA	
input capacitance	C_i	-	-	3.5	-	pF	

2. DC Characteristics 2

($T_{amb} = -40^{\circ}\text{C}$ to $+85^{\circ}\text{C}$, voltages are referenced to GND (ground=0V), unless otherwise specified.)

Parameter	Symbol	Conditions	Min	Typ	Max	Unit	
HIGH-level output voltage	V_{OH}	$V_I = V_{T+}$ or V_{T-}	$I_O = -20\mu\text{A}; V_{CC} = 2.0\text{V}$	1.9	-	-	V
			$I_O = -20\mu\text{A}; V_{CC} = 4.5\text{V}$	4.4	-	-	V
			$I_O = -20\mu\text{A}; V_{CC} = 6.0\text{V}$	5.9	-	-	V
			$I_O = -4.0\text{mA}; V_{CC} = 4.5\text{V}$	3.84	-	-	V
			$I_O = -5.2\text{mA}; V_{CC} = 6.0\text{V}$	5.34	-	-	V
LOW-level output voltage	V_{OL}	$V_I = V_{T+}$ or V_{T-}	$I_O = 20\mu\text{A}; V_{CC} = 2.0\text{V}$	-	-	0.1	V
			$I_O = 20\mu\text{A}; V_{CC} = 4.5\text{V}$	-	-	0.1	V
			$I_O = 20\mu\text{A}; V_{CC} = 6.0\text{V}$	-	-	0.1	V
			$I_O = 4.0\text{mA}; V_{CC} = 4.5\text{V}$	-	-	0.33	V
			$I_O = 5.2\text{mA}; V_{CC} = 6.0\text{V}$	-	-	0.33	V
input leakage current	I_I	$V_I = V_{CC}$ or GND; $V_{CC} = 6.0\text{V}$	-	-	± 1	μA	
supply current	I_{CC}	$V_I = V_{CC}$ or GND; $I_O = 0\text{A}$; $V_{CC} = 6.0\text{V}$	-	-	20	μA	

3. DC Characteristics 3

($T_{amb} = -40^{\circ}\text{C}$ to $+125^{\circ}\text{C}$, voltages are referenced to GND (ground=0V), unless otherwise specified.)

Parameter	Symbol	Conditions	Min	Typ	Max	Unit	
HIGH-level output voltage	V_{OH}	$V_I = V_{T+}$ or V_{T-}	$I_O = -20\mu\text{A}; V_{CC} = 2.0\text{V}$	1.9	-	-	V
			$I_O = -20\mu\text{A}; V_{CC} = 4.5\text{V}$	4.4	-	-	V
			$I_O = -20\mu\text{A}; V_{CC} = 6.0\text{V}$	5.9	-	-	V
			$I_O = -4.0\text{mA}; V_{CC} = 4.5\text{V}$	3.88	-	-	V
			$I_O = -5.2\text{mA}; V_{CC} = 6.0\text{V}$	5.38	-	-	V
LOW-level output voltage	V_{OL}	$V_I = V_{T+}$ or V_{T-}	$I_O = 20\mu\text{A}; V_{CC} = 2.0\text{V}$	-	-	0.1	V
			$I_O = 20\mu\text{A}; V_{CC} = 4.5\text{V}$	-	-	0.1	V
			$I_O = 20\mu\text{A}; V_{CC} = 6.0\text{V}$	-	-	0.1	V
			$I_O = 4.0\text{mA}; V_{CC} = 4.5\text{V}$	-	-	0.33	V
			$I_O = 5.2\text{mA}; V_{CC} = 6.0\text{V}$	-	-	0.33	V
input leakage current	I_I	$V_I = V_{CC}$ or GND; $V_{CC} = 6.0\text{V}$	-	-	± 1	μA	
supply current	I_{CC}	$V_I = V_{CC}$ or GND; $I_O = 0\text{A}$; $V_{CC} = 6.0\text{V}$	-	-	20	μA	

4. C Characteristics 1

($T_{amb}=25^{\circ}\text{C}$, voltages are referenced to GND (ground=0V), unless otherwise specified.)

Parameter	Symbol	Conditions	Min	Typ	Max	Unit	
nA, nB tonY propagation delay	t_{PLH}, t_{PHL}	see Figure 5	$V_{CC}=2.0\text{V}$	-	41	125	ns
			$V_{CC}=4.5\text{V}$	-	15	25	ns
			$V_{CC}=5.0\text{V}; C_L=15\text{pF}$	-	12	-	ns
			$V_{CC}=6.0\text{V}$	-	12	21	ns
transition time	t_{THL}, t_{TLH}	see Figure 5	$V_{CC}=2.0\text{V}$	-	19	75	ns
			$V_{CC}=4.5\text{V}$	-	7	15	ns
			$V_{CC}=6.0\text{V}$	-	6	13	ns

5. AC Characteristics 2

($T_{amb}=-40^{\circ}\text{C}$ to $+85^{\circ}\text{C}$, voltages are referenced to GND (ground=0V), unless otherwise specified.)

Parameter	Symbol	Conditions	Min	Typ	Max	Unit	
nA, nB tonY propagation delay	t_{PLH}, t_{PHL}	see Figure 5	$V_{CC}=2.0\text{V}$	-	-	155	ns
			$V_{CC}=4.5\text{V}$	-	-	31	ns
			$V_{CC}=6.0\text{V}$	-	-	26	ns
transition time	t_{THL}, t_{TLH}	see Figure 5	$V_{CC}=2.0\text{V}$	-	-	95	ns
			$V_{CC}=4.5\text{V}$	-	-	19	ns
			$V_{CC}=6.0\text{V}$	-	-	15	ns

6. AC Characteristics 3

($T_{amb}=-40^{\circ}\text{C}$ to $+125^{\circ}\text{C}$, voltages are referenced to GND (ground=0V), unless otherwise specified.)

Parameter	Symbol	Conditions	Min	Typ	Max	Unit	
nA, nB tonY propagation delay	t_{PLH}, t_{PHL}	see Figure 5	$V_{CC}=2.0\text{V}$	-	-	190	ns
			$V_{CC}=4.5\text{V}$	-	-	38	ns
			$V_{CC}=6.0\text{V}$	-	-	32	ns
transition time	t_{THL}, t_{TLH}	see Figure 5	$V_{CC}=2.0\text{V}$	-	-	110	ns
			$V_{CC}=4.5\text{V}$	-	-	22	ns
			$V_{CC}=6.0\text{V}$	-	-	19	ns

7. Transfer Characteristics 1

($T_{amb}=25^{\circ}\text{C}$, voltages are referenced to GND (ground=0V), unless otherwise specified.)

Parameter	Symbol	Conditions	Min	Typ	Max	Unit
positive-going threshold voltage	V_{T+}	$V_{CC}=2.0\text{V}$	0.7	-	1.5	V
		$V_{CC}=4.5\text{V}$	1.7	-	3.15	V
		$V_{CC}=6.0\text{V}$	2.1	-	4.2	V
negative-going threshold voltage	V_{T-}	$V_{CC}=2.0\text{V}$	0.3	-	0.9	V
		$V_{CC}=4.5\text{V}$	0.9	-	2.0	V
		$V_{CC}=6.0\text{V}$	1.2	-	2.6	V
hysteresis voltage	V_H	$V_{CC}=2.0\text{V}$	-	0.66	-	V
		$V_{CC}=4.5\text{V}$	-	0.98	-	V
		$V_{CC}=6.0\text{V}$	-	1.25	-	V

8. Transfer Characteristics 2

($T_{amb}=-40^{\circ}\text{C}$ to $+85^{\circ}\text{C}$, voltages are referenced to GND (ground=0V), unless otherwise specified.)

Parameter	Symbol	Conditions	Min	Typ	Max	Unit
positive-going threshold voltage	V_{T+}	$V_{CC}=2.0\text{V}$	0.7	-	1.5	V
		$V_{CC}=4.5\text{V}$	1.7	-	3.15	V
		$V_{CC}=6.0\text{V}$	2.1	-	4.2	V
negative-going threshold voltage	V_{T-}	$V_{CC}=2.0\text{V}$	0.3	-	0.9	V
		$V_{CC}=4.5\text{V}$	0.9	-	2.0	V
		$V_{CC}=6.0\text{V}$	1.2	-	2.6	V
hysteresis voltage	V_H	$V_{CC}=2.0\text{V}$	-	0.66	-	V
		$V_{CC}=4.5\text{V}$	-	0.98	-	V
		$V_{CC}=6.0\text{V}$	-	1.25	-	V

9. Transfer Characteristics 3

($T_{amb}=-40^{\circ}\text{C}$ to $+125^{\circ}\text{C}$, voltages are referenced to GND (ground=0V), unless otherwise specified.)

Parameter	Symbol	Conditions	Min	Typ	Max	Unit
positive-going threshold voltage	V_{T+}	$V_{CC}=2.0\text{V}$	0.7	-	1.5	V
		$V_{CC}=4.5\text{V}$	1.7	-	3.15	V
		$V_{CC}=6.0\text{V}$	2.1	-	4.2	V
negative-going threshold voltage	V_{T-}	$V_{CC}=2.0\text{V}$	0.3	-	0.9	V
		$V_{CC}=4.5\text{V}$	0.9	-	2.0	V
		$V_{CC}=6.0\text{V}$	1.2	-	2.6	V
hysteresis voltage	V_H	$V_{CC}=2.0\text{V}$	-	0.66	-	V
		$V_{CC}=4.5\text{V}$	-	0.98	-	V
		$V_{CC}=6.0\text{V}$	-	1.25	-	V

Testing Circuit

1. AC Testing Circuit

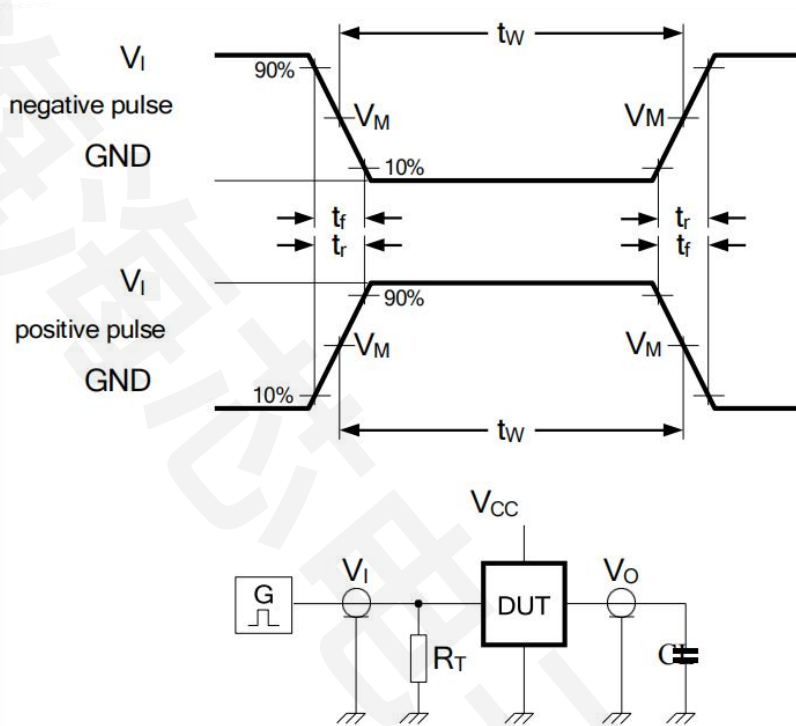

Figure 4. Test circuit for measuring switching times

Definitions for test circuit:

C_L =load capacitance including jig and probe capacitance.

R_T =termination resistance should be equal to the output impedance Z_o of the pulse generator.

2. AC Testing Waveforms

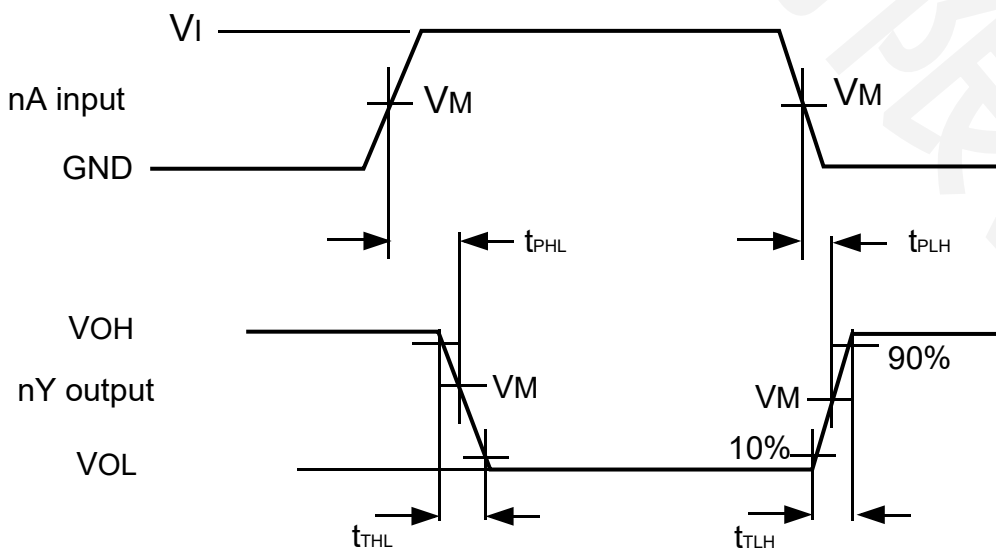

Figure 5. Input to output propagation delays

Transfer Characteristics Waveforms

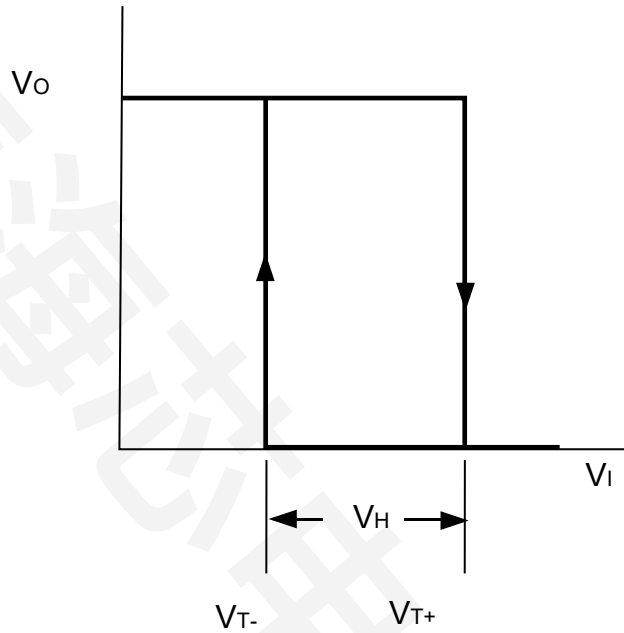

Figure 6. Transfer characteristics

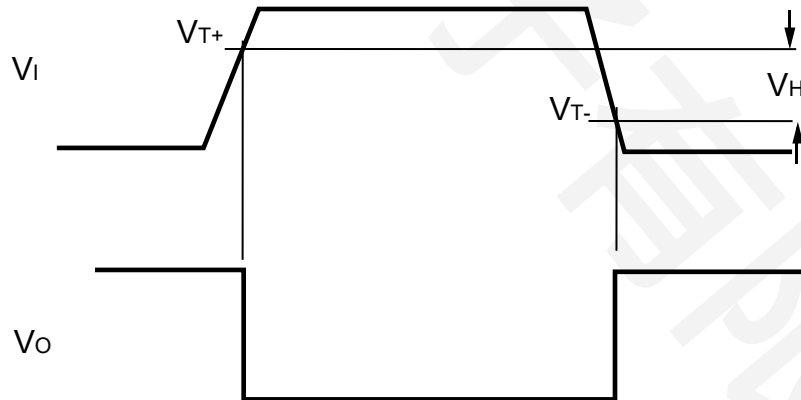

Figure 7. Transfer characteristics definitions

1. Measurement Points

Type	Input	Output		
	V_M	V_M	V_X	V_Y
74HC14D-HX/74HC14S-HX	$0.5 \times V_{CC}$	$0.5 \times V_{CC}$	$0.1 \times V_{CC}$	$0.9 \times V_{CC}$

2. Test Data

Type	Input		Load	Test
	V_i	t_r, t_f	C_L	
74HC14D-HX/74HC14S-HX	V_{CC}	6.0ns	15pF, 50pF	t_{PLH}, t_{PHL}

Package Information

DIP 14 package information

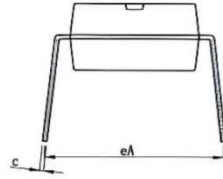
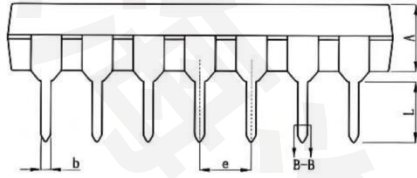

Symbol	Millimeter		
	Min	Nom	Max
A	3.20	3.30	3.40
b	0.44	----	0.53
b1	0.43	0.46	0.49
c	0.25	----	0.30
c1	0.24	0.25	0.26
D	18.95	19.05	19.15
E	6.25	6.35	6.45
e	2.54(BSC)		
eA	7.62	----	9.50
L	3.00	----	----

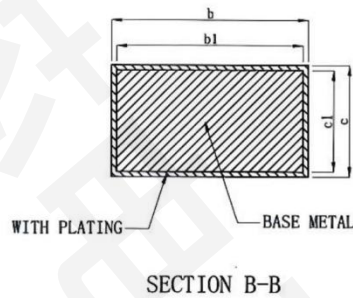
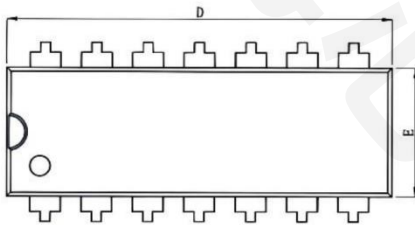

SOP 14 package information

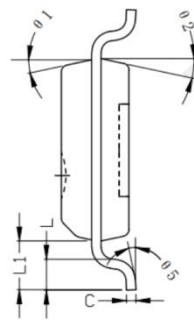
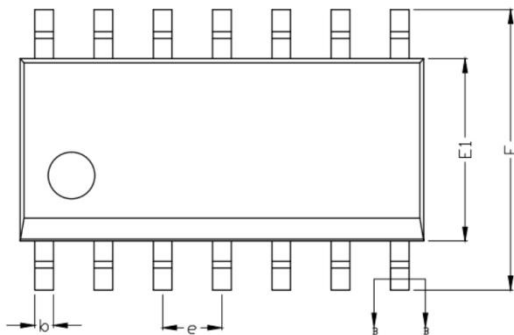

SYMBOL	MILLIMETER		
	MIN	NOM	MAX
A	--	--	1.70
A1	0.10	0.15	0.21
A2	1.40	1.45	1.50
A3	0.60	0.65	0.70
b	0.33	--	0.47
b1	0.32	0.41	0.44
c	0.20	--	0.24
c1	0.19	0.20	0.21
D	8.45	8.60	8.75
E	5.80	6.00	6.20
E1	3.85	3.90	4.00
e	1.27(BSC)		
L	0.50	0.60	0.70
L1	1.10(BSC)		
theta 1	8°	~	15°
theta 2	8°	~	15°
theta 3	8°	~	15°
theta 4	8°	~	15°
theta 5	0°	~	6°

