



## U74CBTLV3257

CMOS IC

### LOW-VOLTAGE DUAL 4-BIT 1-OF-2 FET MULTIPLEXER/DEMULTIPLEXER

#### DESCRIPTION

The **U74CBTLV3257** device is a 4-bit 1-of-2 high-speed FET multiplexer/demultiplexer. The low on state resistance of the switch allows connections to be made with minimal propagation delay.

The select (S) input controls the data flow. The FET multiplexers/demultiplexers are disabled when the output-enable ( $\overline{OE}$ ) input is high.

To ensure the high-impedance state during power up or power down,  $\overline{OE}$  should be tied to  $V_{CC}$  through a pull-up resistor; the minimum value of the resistor is determined by the current-sinking capability of the driver.

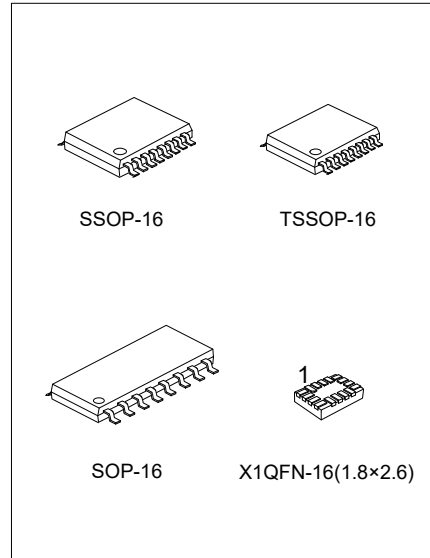

#### FEATURES

- \* 5Ω Switch Connection Between Two Ports
- \* Rail-to-Rail Switching on Data I/O Ports

#### ORDERING INFORMATION

Ordering Number		Package	Packing
Lead Free	Halogen Free		
U74CBTLV3257L-S16-R	U74CBTLV3257G-S16-R	SOP-16	Tape Reel
U74CBTLV3257L-R16-R	U74CBTLV3257G-R16-R	SSOP-16	Tape Reel
U74CBTLV3257L-P16-R	U74CBTLV3257G-P16-R	TSSOP-16	Tape Reel
U74CBTLV3257L-QAE-R	U74CBTLV3257G-QAE-R	X1QFN-16(1.8x2.6)	Tape Reel

<p>U74CBTLV3257G-S16-R</p> <p>(1) Packing Type (2) Package Type (3) Green Package</p>	<p>(1) R: Tape Reel (2) S16: SOP-16, R16: SSOP-16, P16: TSSOP-16 QAE: X1QFN-16(1.8x2.6) (3) G: Halogen Free and Lead Free, L: Lead Free</p>
---	---

#### MARKING

SOP-16 / SSOP-16 / TSSOP-16	X1QFN-16(1.8x2.6)
<p>Date Code L: Lead Free G: Halogen Free Lot Code</p>	

## PIN CONFIGURATION

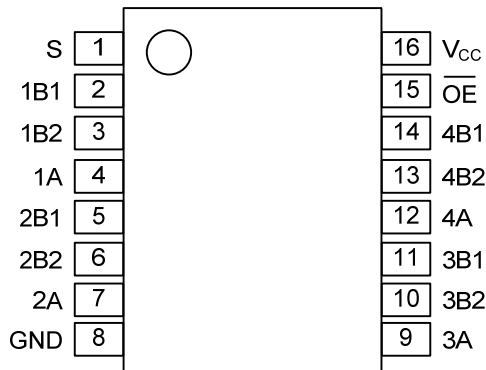

SOP-16 / SSOP-16 / TSSOP-16

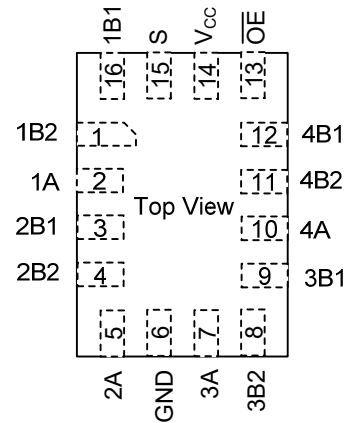

X1QFN-16(1.8x2.6)

## PIN DESCRIPTION

PIN NO.		PIN NAME	I/O	DESCRIPTION
SOP-16 TSSOP-16	X1QFN-16(1.8x2.6)			
1	15	S	I	Select
2	16	1B1	I/O	I/O Channel 1 I/O 1
3	1	1B2	I/O	I/O Channel 1 I/O 2
4	2	1A	I/O	Channel 1 O/I common
5	3	2B1	I/O	I/O Channel 2 I/O 1
6	4	2B2	I/O	I/O Channel 2 I/O 2
7	5	2A	I/O	Channel 2 O/I common
8	6	GND	-	Ground
9	7	3A	I/O	Channel 3 O/I common
10	8	3B2	I/O	I/O Channel 3 I/O 1
11	9	3B1	I/O	I/O Channel 3 I/O 2
12	10	4A	I/O	Channel 4 O/I common
13	11	4B2	I/O	I/O Channel 4 I/O 1
14	12	4B1	I/O	I/O Channel 4 I/O 2
15	13	OE	I	Output Enable, Active-Low
16	14	V <sub>cc</sub>	-	Power

■ FUNCTION TABLE (Each Multiplexer / Demultiplexer)

INPUTS		FUNCTION
OE	S	
L	L	A port = B1 port
L	H	A port = B2 port
H	X	Disconnect

■ LOGIC DIAGRAM (positive logic)

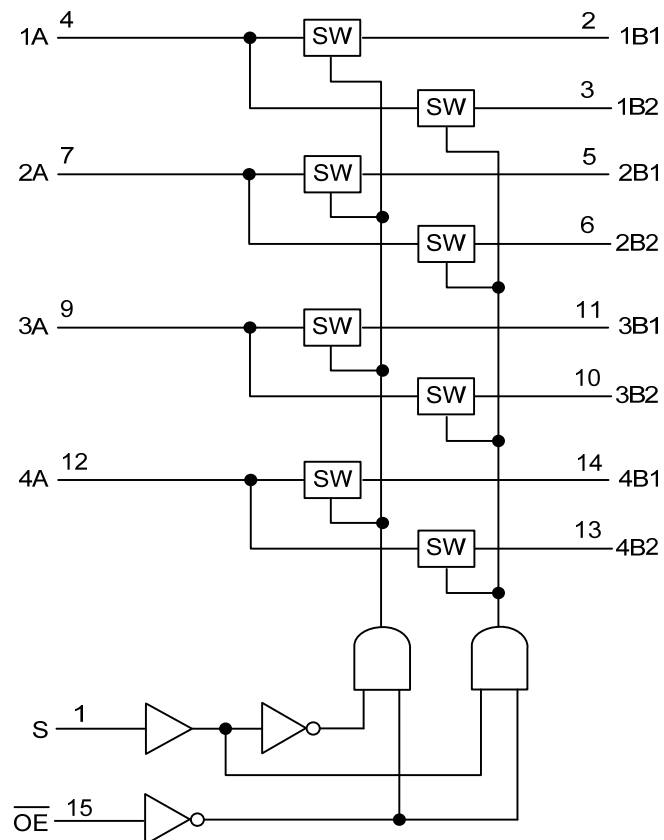

■ SIMPLIFIED SCHEMATIC (each FET switch)

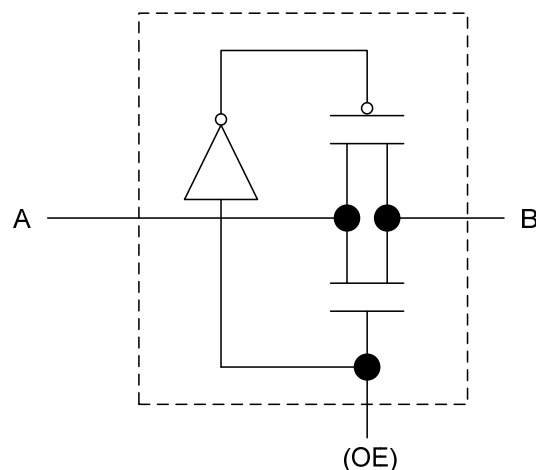

## ■ ABSOLUTE MAXIMUM RATING

PARAMETER	SYMBOL	CONDITIONS	RATINGS	UNIT
Supply Voltage	$V_{CC}$		-0.5 ~ 4.6	V
Input Voltage (Note 2)	$V_{IN}$		-0.5 ~ 4.6	V
Continuous Channel Through $V_{CC}$ or GND			±128	mA
Input Clamp Current	$I_{IK}$	$V_{IN} < 0$	-50	mA
Junction Temperature	$T_J$		+150	°C
Storage Temperature Range	$T_{STG}$		-65 ~ +150	°C

Notes: 1. Absolute maximum ratings are those values beyond which the device could be permanently damaged.

Absolute maximum ratings are stress ratings only and functional device operation is not implied.

2. The input and output voltage ratings may be exceeded if the input and output current ratings are observed.

## ■ THERMAL DATA

PARAMETER	SYMBOL	RATINGS	UNIT	
Junction to Ambient	SOP-16	$\theta_{JA}$	90	°C/W
	SSOP-16		120	°C/W
	TSSOP-16		115	°C/W
	X1QFN-16(1.8×2.6)		160	°C/W

## ■ RECOMMENDED OPERATING COMDITIONS

(Over operating free-air temperature range, unless otherwise specified)

PARAMETER	SYMBOL	TEST CONDITIONS	MIN	TYP	MAX	UNIT
Supply Voltage	$V_{CC}$		2.3		3.6	V
High-Control Input Voltage	$V_{IH}$	$V_{CC}=2.3V\sim 2.7V$	1.7			V
		$V_{CC}=2.7V\sim 3.6V$	2			
Low- Control Input Voltage	$V_{IL}$	$V_{CC}=2.3V\sim 2.7V$			0.7	V
		$V_{CC}=2.7V\sim 3.6V$			0.8	
Operating Temperature	$T_A$		-40		+125	°C

Note: All unused control inputs of the device must be held at  $V_{CC}$  or GND to ensure proper device operation.

## ■ ELECTRICAL CHARACTERISTICS (Unless otherwise specified)

PARAMETER	SYMBOL	TEST CONDITIONS	$T_A=25^\circ\text{C}$			$T_A=-40^\circ\text{C}\sim +125^\circ\text{C}$			UNIT
			MIN	TYP	MAX	MIN	TYP	MAX	
Digital Input Diode Voltage	$V_{IK}$	$V_{CC}=3V, I_I=-18mA$			-1.2			-1.2	V
Input Leakage Current	$I_I$	$V_{CC}=3.6V, V_I=V_{CC}$ or GND			±1			±20	µA
Quiescent Supply Current	$I_{CC}$	$V_{CC}=3.6V, V_I=V_{CC}$ or GND, $I_O=0$			10			50	µA
Additional Quiescent Supply Current (Note 1)	Control Inputs	$\Delta I_{CC}$			300			2000	µA
Resistor Between Two Ports (Note 2)	$R_{ON}$	$V_{CC}=2.3V$ TYP at	$V_I=0$	$I_I=64mA$	5	8		15	Ω
			$I_I=24mA$	5	8		15	Ω	
		$V_{CC}=2.5V$	$V_I=1.7V$	$I_I=15mA$	27	40		60	Ω
			$V_I=0V$	$I_I=64mA$	5	7		11	Ω
		$V_{CC}=3V$	$I_I=24mA$	5	7		11	Ω	
			$V_I=2.4V$	$I_I=15mA$	10	15		26	Ω

Notes: 1. This is the increase in supply current for each input that is at the specified voltage level, rather than  $V_{CC}$  or GND.

2. Measured by the voltage drop between the A and the B terminals at the indicated current through the switch. On-state resistance is determined by the lower of the voltages of the two (A or B) terminals.

### SWITCHING CHARACTERISTICS

See Fig. 1 and Fig. 2 for test circuit and waveforms.

PARAMETER	SYMBOL	TEST CONDITIONS	T <sub>A</sub> =25°C			T <sub>A</sub> =-40°C~+125°C			UNIT
			MIN	TYP	MAX	MIN	TYP	MAX	
Propagation Delay From Input (A or B) (Note) to Output (B or A)	t <sub>pd</sub> (t <sub>PLH</sub> /t <sub>PHL</sub> )	V <sub>CC</sub> =2.5V±0.2V			0.15			0.3	ns
		V <sub>CC</sub> =3.3V±0.3V			0.25			0.5	ns
Propagation Delay From Input (S) to Output (A or B)		V <sub>CC</sub> =2.5V±0.2V	1		7.3			8.8	ns
		V <sub>CC</sub> =3.3V±0.3V	1		6.8			8.3	ns
Propagation Delay From Input (S) to Output (A or B)	t <sub>en</sub> (t <sub>PZL</sub> /t <sub>PZH</sub> )	V <sub>CC</sub> =2.5V±0.2V	1		7			9	ns
		V <sub>CC</sub> =3.3V±0.3V	1		6.5			8.5	ns
Propagation Delay From Input ( $\overline{OE}$ ) to Output (A or B)		V <sub>CC</sub> =2.5V±0.2V	1		7			9	ns
		V <sub>CC</sub> =3.3V±0.3V	1		6.5			8.5	ns
Propagation Delay From Input (S) to Output (A or B)	t <sub>dis</sub> (t <sub>PLZ</sub> /t <sub>PHZ</sub> )	V <sub>CC</sub> =2.5V±0.2V	1		5.5			7.5	ns
		V <sub>CC</sub> =3.3V±0.3V	1		5.3			7.3	ns
Propagation Delay From Input ( $\overline{OE}$ ) to Output (A or B)		V <sub>CC</sub> =2.5V±0.2V	1		5.5			7	ns
		V <sub>CC</sub> =3.3V±0.3V	1		5.5			7	ns

Note: The propagation delay is the calculated RC time constant of the typical on-state resistance of the switch and the specified load capacitance, when driven by an ideal voltage source (zero output impedance).

### OPERATING CHARACTERISTICS (T<sub>A</sub>=25°C, unless otherwise specified)

PARAMETER		SYMBOL	TEST CONDITIONS	MIN	TYP	MAX	UNIT
Control input Capacitance	Control Inputs	C <sub>i</sub>	V <sub>O</sub> =3V or 0		3		pF
I/O Capacitance (OFF)	A Port	C <sub>IO(OFF)</sub>	V <sub>O</sub> =3V or 0, $\overline{OE}$ =V <sub>CC</sub>		10.5		pF
	B Port				5.5		pF

## TEST CIRCUIT AND WAVEFORMS

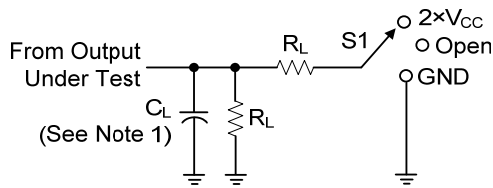

$V_{CC}$	$C_L$	$R_L$	$V_{\Delta}$
$2.5V \pm 0.2V$	30pF	500 $\Omega$	0.15V
$3.3V \pm 0.3V$	50pF	500 $\Omega$	0.3V

TEST	S1
$t_{PLH}/t_{PHL}$	Open
$t_{PLZ}/t_{PZL}$	$2 \times V_{CC}$
$t_{PHZ}/t_{PZH}$	GND

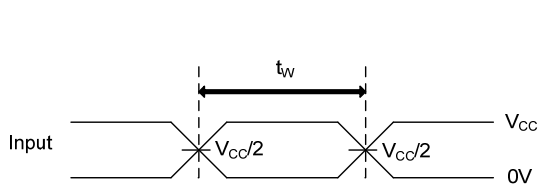

PULSE DURATION

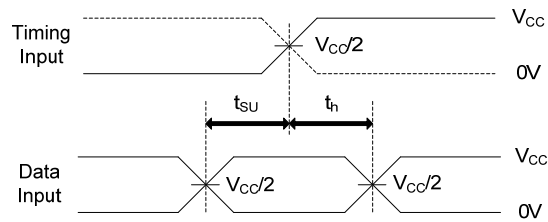

SETUP AND HOLD TIMES

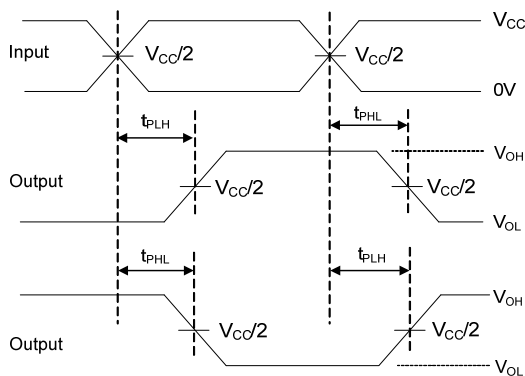

PROPAGATION DELAY TIMES

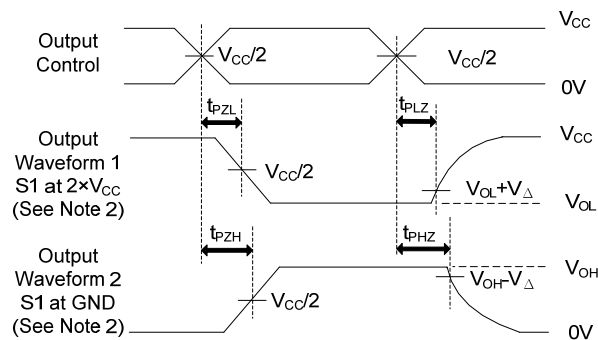

ENABLE AND DISABLE TIMES

Notes: 1.  $C_L$  includes probe and jig capacitance.

2. Waveform 1 is for an output with internal conditions such that the output is low except when disabled by the output control.

Waveform 2 is for an output with internal conditions such that the output is high except when disabled by the output control.

3. All input pulses are supplied by generators having the following characteristics:

$P_{RR} \leq 10\text{MHz}$ ,  $Z_O = 50\Omega$ ,  $t_r \leq 2\text{ns}$ ,  $t_f \leq 2\text{ns}$ .

4.  $t_{PLZ}$  and  $t_{PHZ}$  are the same as  $t_{dis}$ .

5.  $t_{PZL}$  and  $t_{PZH}$  are the same as  $t_{en}$ .

6.  $t_{PLH}$  and  $t_{PHL}$  are the same as  $t_{pd}$ .

### Load circuitry and voltage waveforms

UTC assumes no responsibility for equipment failures that result from using products at values that exceed, even momentarily, rated values (such as maximum ratings, operating condition ranges, or other parameters) listed in products specifications of any and all UTC products described or contained herein. UTC products are not designed for use in life support appliances, devices or systems where malfunction of these products can be reasonably expected to result in personal injury. Reproduction in whole or in part is prohibited without the prior written consent of the copyright owner. UTC reserves the right to make changes to information published in this document, including without limitation specifications and product descriptions, at any time and without notice. This document supersedes and replaces all information supplied prior to the publication hereof.