

FEATURES

- Low Forward Voltage Drop
- Guard Ring Construction for Transient Protection
- Negligible Reverse Recovery Time
- Low Capacitance

MECHANICAL DATA

- Case: SOD-123
- Terminals: Solderable per MIL-STD-750, Method 2026
- Approx. Weight: 16mg/0.00056oz

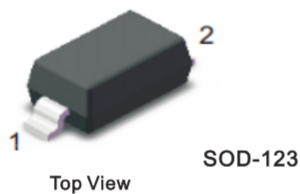

PINNING

PIN	DESCRIPTION
1	Cathode
2	Anode



Maximum Ratings and Electrical characteristics

Rating s at 25 °C ambient temperature unless otherwise specified.

Parameter	Symbols	SD103AW	SD103BW	SD103CW	Units
Peak Repetitive Reverse Voltage	V_{RRM}	40	30	20	V
RMS reverse voltage	V_{RMS}	28	21	14	V
Working Peak Reverse Voltage	V_{DC}	40	30	20	V
Peak Forward Surge Current, 8.3ms single half sine-wave superimposed on rated load (JEDEC method)	I_{FSM}	13			A
Maximum Instantaneous Forward Voltage $I_F=20mA$ $I_F=200mA$	V_F	0.37 0.60			V
Power Dissipation	P_D	400			mW
Reverse current $V_R=30V$ $V_R=20V$ $V_R=10V$	I_R	5 — —	— 5 —	— — 5	μA
Thermal Resistance, Junction to Ambient Air	$R_{\theta JA}$	300			°C/W
Reverse voltage $I_R=100\mu A$	$V_{(BR)}$	SD103AW SD103BW SD103CW	40 30 20		V
Reverse recovery time $I_F=I_R=200mA, I_{rr}=0.1 \times I_R, R_L=100\Omega$	t_{rr}	10			ns
Forward Continuons Current	I_{FM}	350			mA
Total capacitance $V_R=0V, f=1MHz$	C_{tot}	28			pF
Junction temperature	T_j	125			°C
Storage temperature	T_{stg}	-55 ~ +150			°C

Fig.1 Power Derating Curve

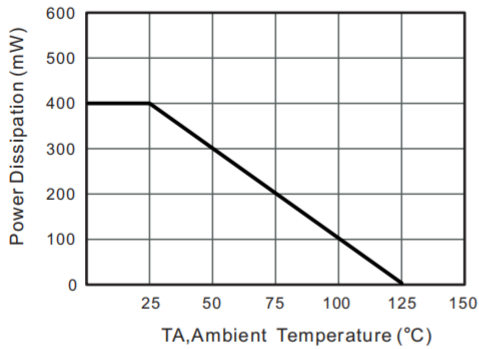

Fig.2 Typical Reverse Characteristics

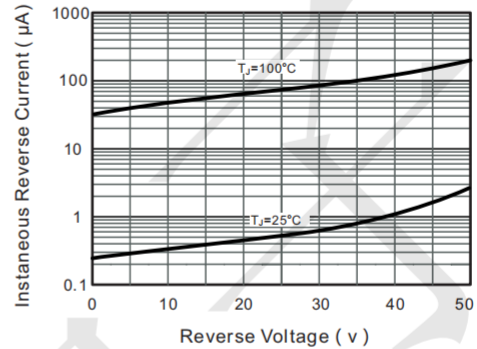

Fig.3 Forward Characteristics

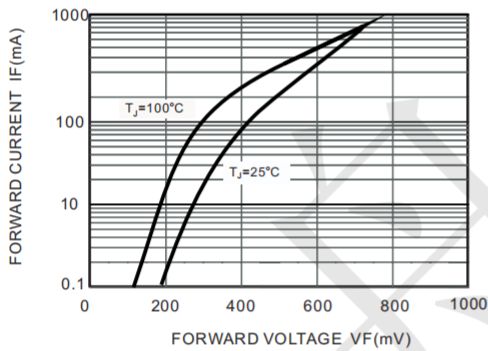

Fig.4 Maximum Non-Repetitive Peak Forward Surge Current

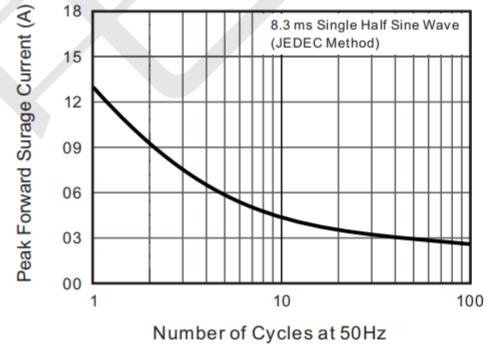

Fig.5 Typical Junction Capacitance

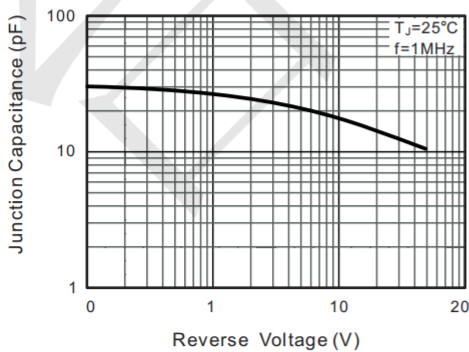
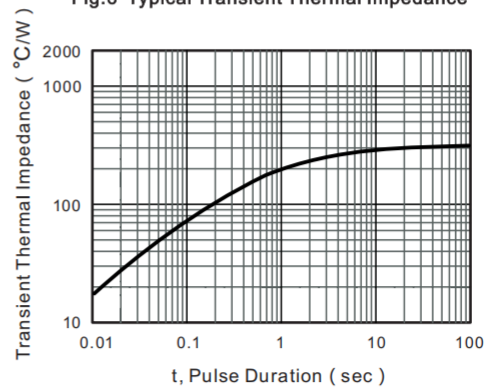
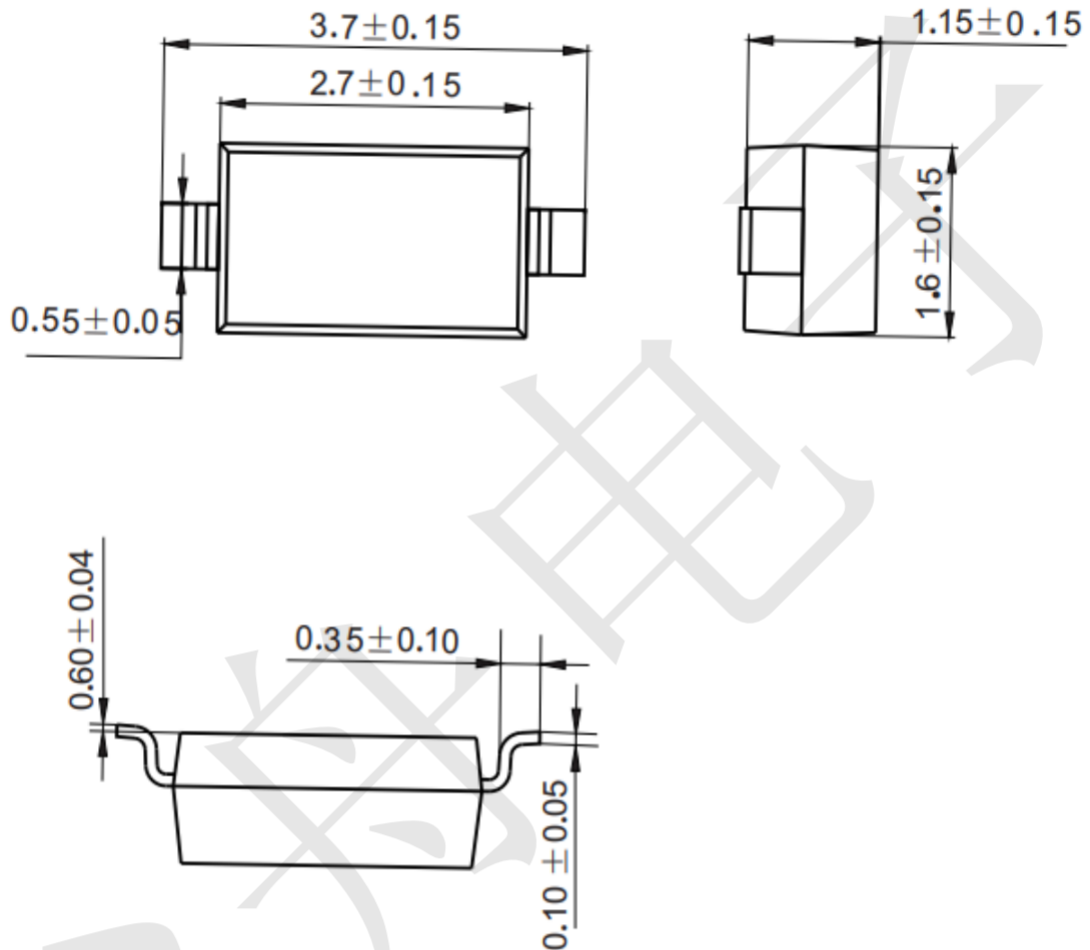

Fig.6 Typical Transient Thermal Impedance



Package information (Unit: mm)

SOD-123



Mounting Pad Layout (Unit: mm)

