



U74HCT04

CMOS IC

HEX INVERTERS

DESCRIPTION

The U74HCT04 devices contain six independent inverters. They perform the Boolean function $Y = \bar{A}$ in positive logic.

FEATURES

- * Operating Voltage Range of 4.5V to 5.5V
- * Low Power Consumption
- * $\pm 4\text{mA}$ Output Drive at 5V
- * Low Input Current of 0.1 μA Max.
- * Inputs are TTL-Voltage compatible

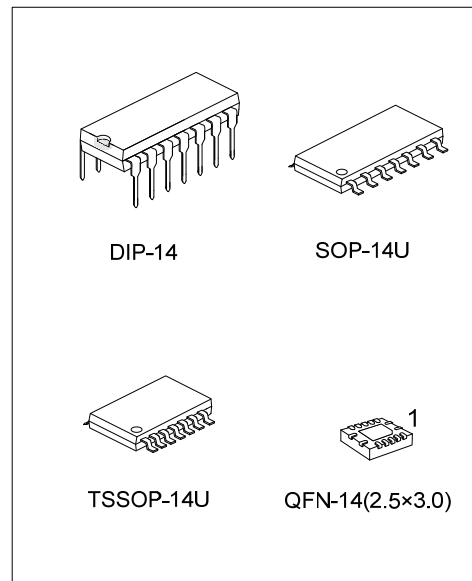

ORDERING INFORMATION

Ordering Number		Package	Packing
Lead Free	Halogen Free		
U74HCT04L-D14-T	U74HCT04G-D14-T	DIP-14	Tube
U74HCT04L-UEA-R	U74HCT04G-UEA-R	SOP-14U	Tape Reel
U74HCT04L-UEB-R	U74HCT04G-UEB-R	TSSOP-14U	Tape Reel
U74HCT04L-QAF-R	U74HCT04G-QAF-R	QFN-14(2.5x3.0)	Tape Reel

<p>U74HCT04G-D14-T</p> <p>(1) Packing Type</p> <p>(2) Package Type</p> <p>(3) Green Package</p>	<p>(1) T: Tube, R: Tape Reel</p> <p>(2) DIP: DIP-14, UEA: SOP-14U, UEB: TSSOP-14U QAF: QFN-14(2.5x3.0)</p> <p>(3) G: Halogen Free and Lead Free, L: Lead Free</p>
---	---

MARKING

PACKAGE	MARKING
DIP-14	
SOP-14U TSSOP-14U	
QFN-14(2.5×3.0)	

PIN CONFIGURATION

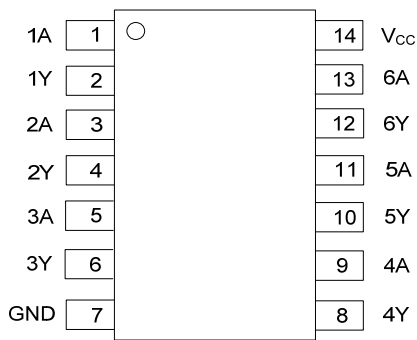

SOP-14U / TSSOP-14U

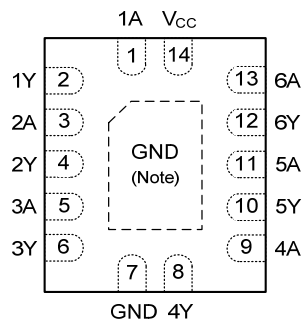

Note: Connect exposed pad to GND

QFN-14(2.5×3.0)
(TOP View)

FUNCTION TABLE (each gate)

INPUT(A)	OUTPUT(Y)
L	H
H	L

LOGIC DIAGRAM (positive logic)

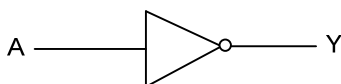

■ ABSOLUTE MAXIMUM RATING (T_A=25°C, unless otherwise specified) (Note 1)

PARAMETER	SYMBOL	CONDITIONS	RATINGS	UNIT
Supply Voltage	V _{CC}		-0.5 ~ 7	V
Input Clamp Current (Note 2)	I _{IK}	V _{IN} <0 or V _{IN} >V _{CC}	±20	mA
Output Clamp Current (Note 2)	I _{OK}	V _{OUT} <0 or V _{OUT} >V _{CC}	±20	mA
Output Current	I _{OUT}	V _{OUT} =0 to V _{CC}	±25	mA
V _{CC} or GND Current	I _{CC}		±50	mA
Storage Temperature	T _{STG}		-65 ~ +150	°C

Notes: 1. Absolute maximum ratings are those values beyond which the device could be permanently damaged. Absolute maximum ratings are stress ratings only and functional device operation is not implied.

2. The input and output voltage ratings may be exceeded if the input and output current ratings are observed.

■ RECOMMENDED OPERATING CONDITIONS (T_A=25°C, unless otherwise specified)

PARAMETER	SYMBOL	CONDITIONS	MIN	TYP	MAX	UNIT
Supply Voltage	V _{CC}	Operating	4.5		5.5	V
Input Voltage	V _{IN}		0		V _{CC}	V
Output Voltage	V _{OUT}		0		V _{CC}	V
Operating Temperature	T _A		-40		+125	°C
Input transition Rise or Fall Time	t _R / t _F				500	ns

■ THERMAL DATA

PARAMETER	SYMBOL	RATINGS	UNIT
Junction to Ambient	DIP-14	100	°C/W
	SOP-14U	125	°C/W
	TSSOP-14U	150	°C/W

■ STATIC CHARACTERISTICS (T_A=25°C, unless otherwise specified)

PARAMETER	SYMBOL	TEST CONDITIONS	MIN	TYP	MAX	UNIT
High-Level Input Voltage	V _{IH}	V _{CC} =4.5V~5.5V	2			V
Low-Level Input Voltage	V _{IL}	V _{CC} =4.5V~5.5V			0.8	V
High-Level Output Voltage	V _{OH}	V _{CC} =4.5V I _{OH} =-20μA	4.4	4.499		V
			I _{OH} =-4mA	3.98		
Low-Level Output Voltage	V _{OL}	V _{IN} =V _{IH} or V _{IL} I _{OL} =20μA		0.001	0.1	V
			I _{OL} =4mA			0.26
Input Leakage Current	I _I	V _{CC} =5.5V			±100	nA
Quiescent Supply Current	I _{CC}	V _{CC} =5.5V, V _{IN} =V _{CC} or 0, I _O =0			2	μA
Additional Quiescent Supply Current	ΔI _{CC}	V _{CC} =5.5V, One input at 0.5V or 2.4V, other inputs at V _{CC} or 0			2.4	mA
Input Capacitance	C _I	V _{CC} =4.5V to 5.5V			10	pF

■ DYNAMIC CHARACTERISTICS (Input: t_R, t_F=6ns, C_L=50pF, PRR≤1MHz, unless otherwise specified)

PARAMETER	SYMBOL	TEST CONDITIONS	MIN	TYP	MAX	UNIT
Propagation Delay From Input (A) to Output (Y)	t _{PLH} /t _{PHL}	V _{CC} =4.5V			20	ns
		V _{CC} =5.5V			18	ns
Rise/Fall Time for Output (Y)	t _t	V _{CC} =4.5V			15	ns
		V _{CC} =5.5V			14	ns

■ OPERATING CHARACTERISTICS

PARAMETER	SYMBOL	TEST CONDITIONS	MIN	TYP	MAX	UNIT
Power Dissipation Capacitance	C _{PD}	No Load		20		pF

TEST CIRCUIT AND WAVEFORMS

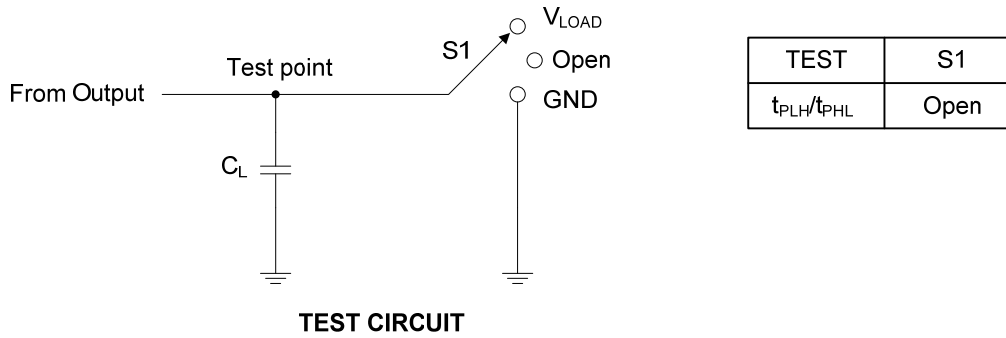

Inputs		V_M	V_{LOAD}	C_L
V_{IN}	t_R, t_F			
3.0 V	6 ns	1.3V	V_{CC}	50 pF

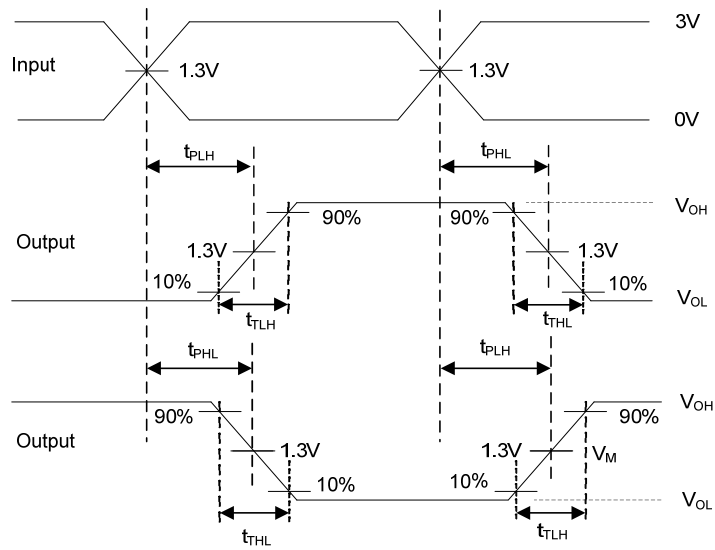
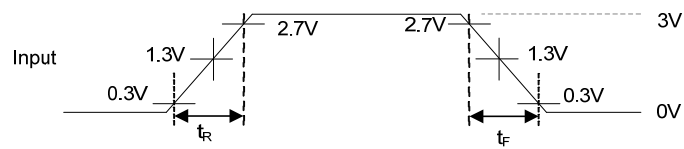

Note: t_{TLH} and t_{THL} are the same as t .

UTC assumes no responsibility for equipment failures that result from using products at values that exceed, even momentarily, rated values (such as maximum ratings, operating condition ranges, or other parameters) listed in products specifications of any and all UTC products described or contained herein. UTC products are not designed for use in life support appliances, devices or systems where malfunction of these products can be reasonably expected to result in personal injury. Reproduction in whole or in part is prohibited without the prior written consent of the copyright owner. UTC reserves the right to make changes to information published in this document, including without limitation specifications and product descriptions, at any time and without notice. This document supersedes and replaces all information supplied prior to the publication hereof.