

REV.	ECN. #	DESCRIPTION	NAME	DATE
A0		NEW RELEASE	Sun	2025.07.18
A1		Optimization of Weld Fillet Welding Performance	Z. L. Li	2025.11.10

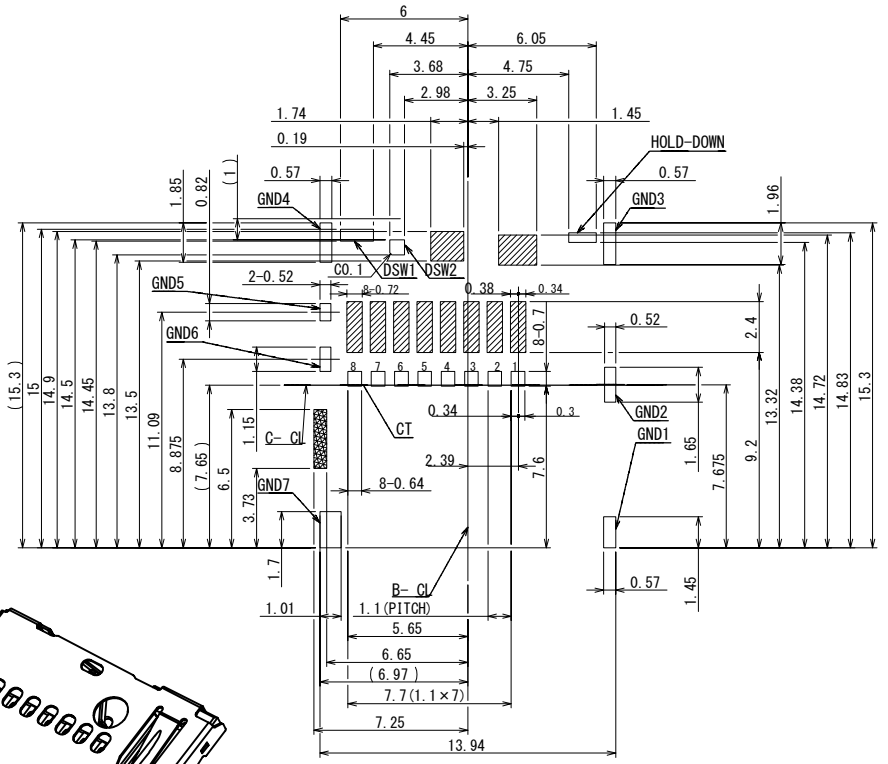

**DATE CODE: JBLYYMDD**

Date :01 stands for 1st day  
 30 stands for 30 days  
 Month:01 stands for January  
 12 stands for December  
 Years:25 stands for 2025  
 26 stands for 2026

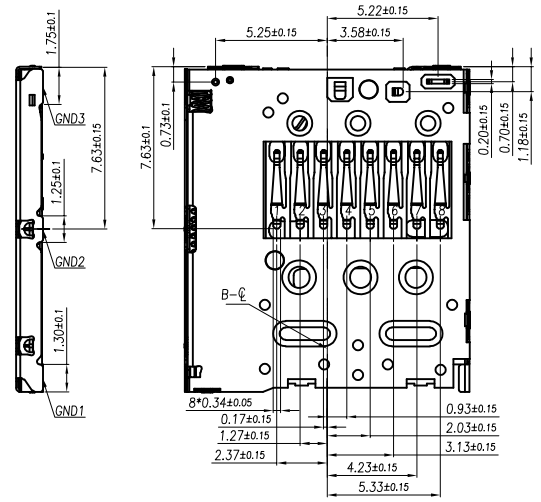
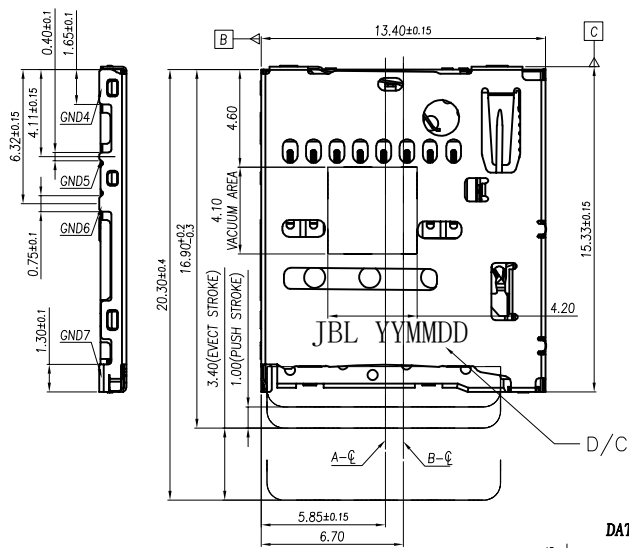
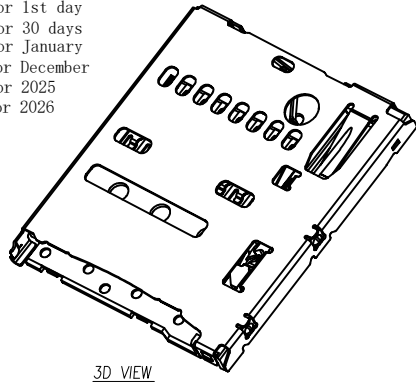

3D VIEW

APPLICABLE P.W.B. DIMENSION(REF.)

RESTRICTED AREA  
 (No pattern and via hole.)

Card misinsertion position.  
 (No components allowed in this area.)

All patterns and Via holes under the connector should be coated by resist.

9	SPRING	1	STAINLESS
8	CAM FOLLOWER	1	STAINLESS
7	LOCK	1	STAINLESS
6	DETECTION SWITCH 2(DSW2)	1	COPPER ALLOY
5	DETECTION SWITCH 1(DSW1)	1	STAINLESS
4	TOP COVER	1	STAINLESS
3	EJECT LEVER	1	GLASS FILLED NY
2	INSULATOR	1	GLASS FILLED LCP
1	CONTACT	8	COPPER ALLOY
NO.	DESCRIPTION	QTY.	MATERIAL

Notes:  
 1.Material:  
 Housing: High Temperature Thermoplastic.  
 Terminal:Copper Alloy  
 Shell: Stainless Steel

2.Plating:  
 Terminal:80u" Ni Underplated Overall  
 3u"Au Min. Plated On Contact Area  
 1u"Au Min. Plated On Solder Area  
 Shell:50u" Ni Underplated Overall  
 G/F Plated On Contact Area And Solder Area

3.Technical Speciality:  
 Rated Voltage: 5V  
 Current Rating: 0.5A  
 Insulation Resistance:1000MΩ Min.  
 Contact Resistance:100mΩ Max.  
 Withstanding Voltage: 500V DC For 1 Minutes.  
 Operating Temperature: -40℃~+85℃ Humidity 80% R.H Max.

CRICUIT DIAGRAM FOR CARD DETECT SWITCH

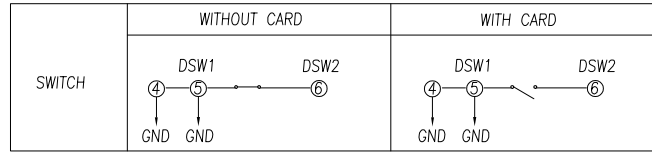

PIN NO.	NAME	MILLIMETERS	INCH
1	DAT2	.X ±0.20	.X ±0.012
2	CD/DAT3	.X ±0.30	.X ±0.012
3	CMD	.XX ±0.20	.XX ±0.008
4	VDD	.XXX ±0.10	.XXX ±0.004
5	CLX		
6	VSS		
7	DATO		
8	DAT1		

THESE DRAWINGS AND SPECIFICATIONS ARE THE PROPERTY OF DongGuan Hang Pai Electronics Co., LTD  
 COPIED OR USED IN ANY MANNER WITHOUT THE PRIOR WRITTEN CONSENT OF DongGuan Hang Pai Electronics Co., LTD

东莞市金比莱五金塑胶科技有限公司  
 DONGGUAN JBL TECH CO., LTD

TITLE	1.25H Push_Push TF CONN.	DR	
PART NO.	102326832	CHKD	
PRO J.	PAGE 1/2	UNITS mm	APPD
SIZE	A4	SCALE 1:1	DIS NO. TF027-003

RoHS

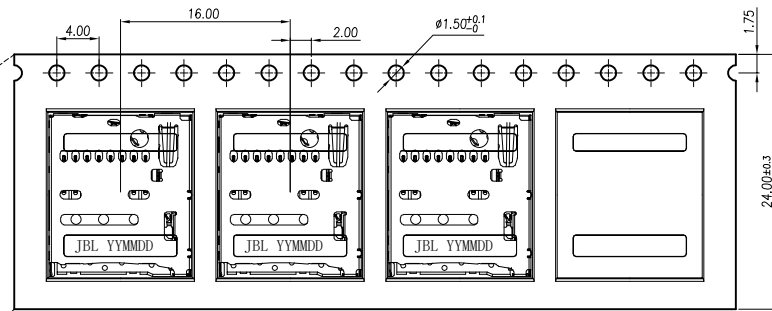

NOTES:

- 1: Packing quantity per plate: 2000PCS/Plate
- 2: Loading and packing method

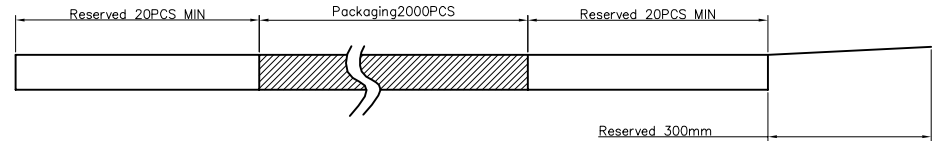

3: Total packaging: 20000PCS/Box

Direction of use

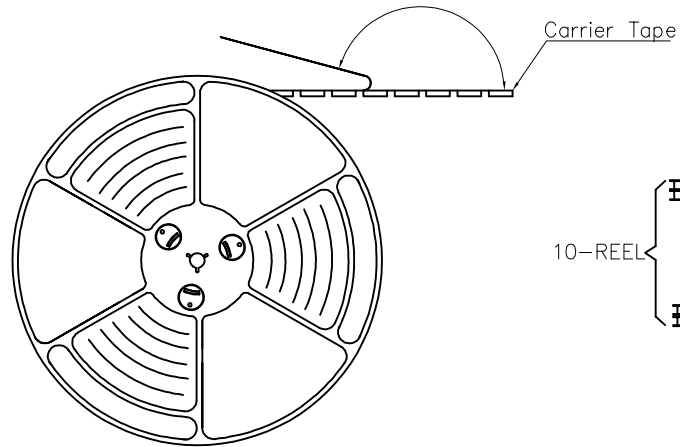

The bottom and top of the carton  
Pad it with a piece of pearl cotton

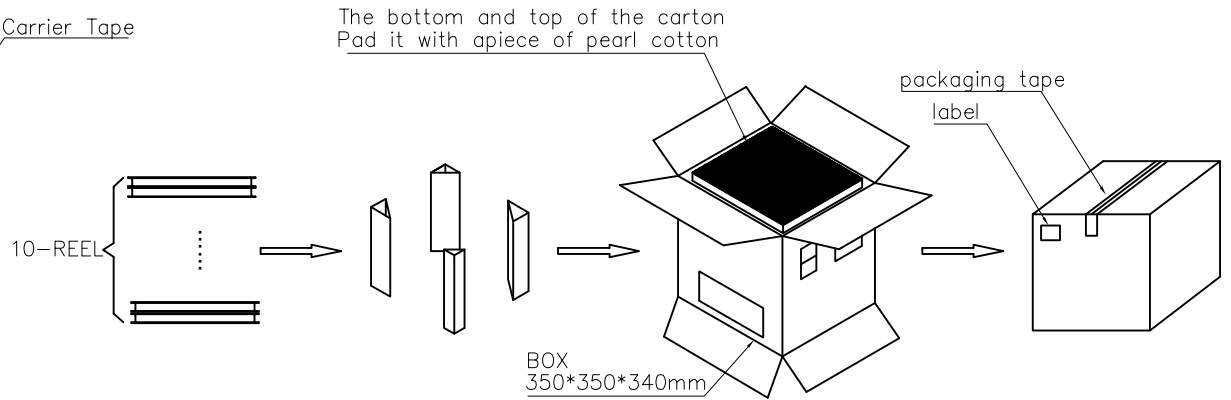

BOX  
350\*350\*340mm

MILLIMETERS	INCH	东莞市金比莱五金塑胶科技有限公司 DONGGUAN JBL TECH CO., LTD			
X. ° ±2°	X. ° ±2°	TITLE	1.25H Push_Push TF CONN.	DR	
.X ±0.30	.X ±0.012	PART NO.	102326832	CHKD	
.XX ±0.20	.XX ±0.008	PRO J.	PAGE 2/2	UNITS mm	APPD
.XXX ±0.10	.XXX ±0.004	SIZE	A4	SCALE 1:1	DIS NO.
THESE DRAWINGS AND SPECIFICATIONS ARE THE PROPERTY OF DONGGUAN JBL TECH CO.,LTD COPIED OR USED IN ANY MANNER WITHOUT THE PRIOR WRITTEN CONSENT OF DONGGUAN JBL TECH CO.,LTD					TF027-003