

RECOMMENDED PCB LAYOUT TOP VIEW (TOLERANCE:±0.05)

RECOMMENDED MATAL MASK T=0.12mm

- SMT SOLDER AREA
- NO PATTERN AND VIA HOLE IN HTIS AREA

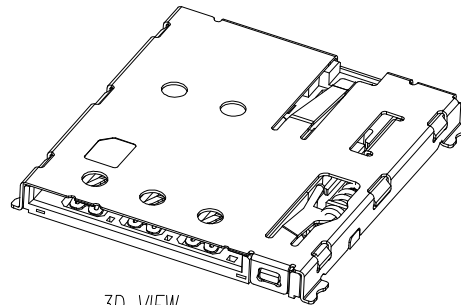
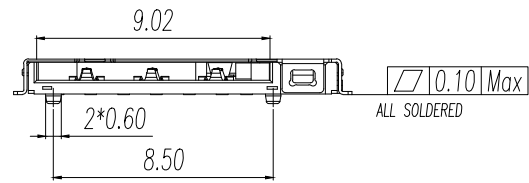

3D VIEW

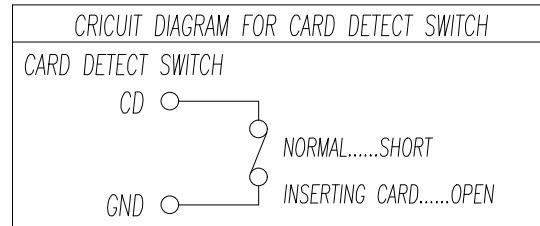

PIN/NO	ASSIGNMENT
C1	VCC
C2	RST
C3	CLK
CD	Detect Switch
C5	GND
C6	VPP
C7	I/O

NOTES:

- 1.MATERIAL:
  - HOUSING: High Temperature Thermoplastic
  - Terminal:Copper Alloy
  - Shell: Stainless Steel
- 2.PLATING:
  - Terminal:30u" Ni UNDERPLATED OVERALL
  - G/F PLATED ON CONTACT AREA AND SOLDER AREA
  - Shell:30u" Ni UNDERPLATED OVERALL
  - G/F PLATED ON CONTACT AREA AND SOLDER AREA
- 3.TECHNICAL SPECIALITY:
  - RATED VOLTAGE: 30V AC MAX.
  - CURRENT RATING: 0.5A MAX.
  - INSULATION RESISTANCE:1000MΩ MIN
  - CONTACT REISTANCE:100mΩ MAX
  - WITHSTANDING VOLTAGE: 500V AC FOR 1 MINUTES
  - OPERATING TEMPERATURE: -40℃~+85℃ Humidity 80% R.H MAX

制图 DRAWN	变更内容 DESCRIPTION	日期 DATE	GENERAL TOLERANCE		制图 DRAWING	EMMA	料号 PART NO.	BX-SMN-1.37HJ	版本 REV.	A
			X.±0.30	X.'±3"						
			.X±0.20	.X'±2"	审核 CHECK	EVA	品名 TITLE	1.37H NANO SIM CARD CONNECTOR(博) 物料#	页次 SHEET	1/1
			.XX±0.10		批准 APPROVAL	JADE	客户料号 CUTM.NO.			
					单位 UNITS	MM	比例 SCALE	1:1		

